

**Vol. 3**

**Mathematical Ideas:  
History, Education, and Cognition**

**International Group  
for the Psychology  
of Mathematics Education**

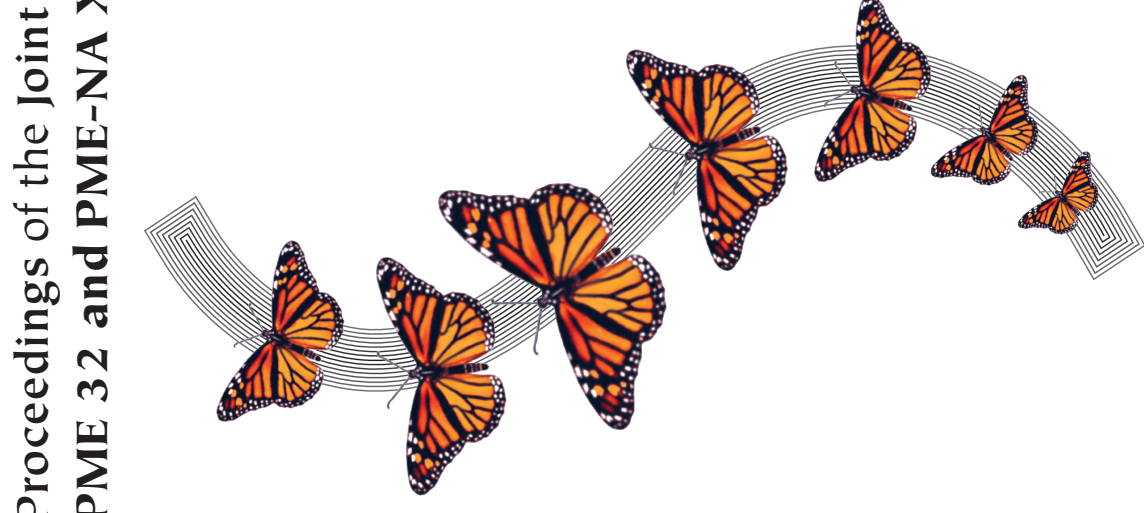

**Proceedings of the Joint Meeting of  
PME 32 and PME-NA XXX**

Morelia, México, 2008

**PME 32  
PME-NA XXX**



**Editors**  
Olimpia Figueras  
José Luis Cortina  
Silvia Alatorre  
Teresa Rojano  
Armando Sepúlveda

**Morelia, México  
July 17-21, 2008**





**International Group  
for the Psychology  
of Mathematics Education**

---

**Proceedings of the Joint Meeting of  
PME 32 and PME-NA XXX**

**Editors**

Olimpia Figueras  
José Luis Cortina  
Silvia Alatorre  
Teresa Rojano  
Armando Sepúlveda

---

**Volume 3**

Research Reports  
Fer-Mou

---

**Morelia, México, July 17-21, 2008**

---

Centro de Investigación y de Estudios Avanzados del IPN  
Universidad Michoacana de San Nicolás de Hidalgo



---

**Cite as:**

Figueras, O., Cortina, J.L., Alatorre, S., Rojano, T., & Sepúlveda, A. (Eds.). (2008). Proceedings of the Joint Meeting of PME 32 and PME-NA XXX. Vol. 3. México: Cinvestav-UMSNH

Website: <http://www.pme32-na30.org.mx>

The proceedings are also available on CD-ROM and on the website

Copyright © 2008 left to authors

*All rights reserved*

ISSN 0771-100X

---

Cover design: Carla Raigoza  
Overall Printing Layout: David Páez  
Logo: Vladimir Soto  
Printing: Guevara Impresores S.A. de C.V.  
Chichimecas Manz. 108 Lote 4  
Col. Ajusco Coyoacán, D.F. 04300 México

# TABLE OF CONTENTS

## VOLUME 3

### Research Reports

<u>Ceneida Fernández</u> , Salvador Llinares, and Julia Valls	1
<i>Implicative analysis of strategies in solving proportional and nonproportional problems</i>	
Eugenio Filloy, Teresa Rojano, and <u>Armando Solares</u>	9
<i>Cognitive tendencies and generating meaning in the acquisition of algebraic substitution and comparison methods</i>	
<u>Vicenç Font</u> and <u>Núria Planas</u>	17
<i>Mathematical practices, semiotic conflicts, and socio-mathematical norms</i>	
Helen J. Forgasz	25
<i>Gender, socio-economic status, and mathematics performance among high achievers</i>	
<u>Cristina Frade</u> and Milene Carneiro Machado	33
<i>Culture and affect: Influences of the teachers' values on students' affect</i>	
John Francisco	41
<i>Mathematical beliefs and behaviors of high school students: Insights from a case study</i>	
<u>Anne Berit Fuglestad</u> and Simon Goodchild	49
<i>Affordances of inquiry: The case of one teacher</i>	
Susan Gerofsky	57
<i>Gesture as diagnosis and intervention in the pedagogy of graphing: Pilot studies and next steps</i>	
<u>Hope Gerson</u> and Janet G. Walter	65
<i>Building connected understanding of calculus</i>	
Camilla Gilmore and <u>Matthew Inglis</u>	73
<i>Process- and object-based thinking in arithmetic</i>	
<u>Pedro Gómez</u> , María J. González, Luis Rico, and José L. Lupiáñez	81
<i>Learning the notion of learning goal in an initial functional training program</i>	

Alejandro S. González-Martín, <u>Fernando Hitt</u> , and Christian Morasse	89
<i>The introduction of the graphic representation of functions through the concept of co-variation and spontaneous representations. A case study</i>	
Eddie Gray and <u>Maria Doritou</u>	97
<i>The number line: Ambiguity and interpretation</i>	
<u>Roxana Grigoraş</u> and Stefan Halverscheid	105
<i>Modelling the travelling salesman problem: Relations between the world of mathematics and the rest of the world</i>	
Markus Hähkiöniemi	113
<i>Durability and meaningfulness of mathematical knowledge - the case of the derivative concept</i>	
Stefan Halverscheid	121
<i>How pre-service teachers use experiments for understanding the circular billiard</i>	
Mathias Hattermann	129
<i>The dragging process in three dimensional dynamic geometry environments (DGE)</i>	
<u>Lulu Healy</u> and Hassan Solange Ahmad Ali Fernandes	137
<i>The role of gestures in the mathematical practices of blind learners</i>	
<u>Aiso Heinze</u> and Frank Lipowsky	145
<i>Informal strategy use for addition and subtraction of three-digit numbers: Accuracy and adaptivity of German 3<sup>rd</sup>-graders</i>	
Beth Herbel-Eisenmann, <u>David Wagner</u> , and Viviana Cortes	153
<i>Encoding authority: Pervasive lexical bundles in mathematics classrooms</i>	
Paul Hernandez-Martinez	161
<i>Institutional practices and the mathematical identity of undergraduates</i>	
<u>Kate Highfield</u> , Joanne Mulligan, and John Hedberg	169
<i>Early mathematics learning through exploration with programable toys</i>	
<u>Marj Horne</u> and Kelly Watson	177
<i>Developing understanding of triangle</i>	

<u>Anesa Hosein</u> , James Aczel, Doug Clow, and John T.E. Richardson	185
<i>Comparison of black-box, glass-box and open-box software for aiding conceptual understanding</i>	
<u>Jodie Hunter</u> and Glenda Anthony	193
<i>Developing relational thinking in an inquiry environment</i>	
Roberta Hunter	201
<i>Do they know what to ask and why? Teachers shifting student questioning from explaining to justifying and generalising reasoning</i>	
<u>Bat-Sheva Ilany</u> and Bruria Margolin	209
<i>Textual literacy in mathematics- an instructional model</i>	
Matthew Inglis and <u>Adrian Simpson</u>	217
<i>Reasoning from features or exemplars</i>	
<u>Sonia Jones</u> and Howard Tanner	225
<i>Reflective discourse and the effective teaching of numeracy</i>	
Leslie H. Kahn, <u>Sandra I. Musanti</u> , Laura Kondek McLeman, José María Menéndez-Gómez, and <u>Barbara Trujillo</u>	233
<i>Teachers of latino students reflect on the implementation of a mathematical task</i>	
Karen Allen Keene	241
<i>Ways of reasoning: Two case studies in an inquiry-oriented differential equations class</i>	
<u>Carolyn Kieran</u> , José Guzmán, A. Boileau, D. Tanguay, and P. Drijvers	249
<i>Orchestrating whole-class discussions in algebra with the aid of CAS technology</i>	
<u>Andrea Knapp</u> , Megan Bomer, and Cynthia Moore	257
<i>Lesson study as a learning environment for mathematics coaches</i>	
<u>Karen Koellner</u> and Jennifer Jacobs	265
<i>Fostering instructional change through mathematics professional development: Focusing on teachers' self- selected goals</i>	
Boris Koichu	273
<i>On considerations of parsimony in mathematical problem solving</i>	

<u>Heidi Krzywacki-Vainio</u> and Markku S. Hannula	281
<i>Development of mathematics teacher students' teacher identity during teaching practice</i>	
Sebastian Kuntze	289
<i>Fostering geometrical proof competency by student-centred writing activities</i>	
<u>Paul Ngee-Kiong Lau</u> and Tee-Yong Hwa	297
<i>Mathematics constructions in an interactive classroom context</i>	
Henry Leppäaho	305
<i>The problem solving MAP method: A tool for mathematical problem solving</i>	
<u>Hee-Chan Lew</u> and Kum-Nam So	313
<i>Two justification processes in solving algebraic problem using graphing technology</i>	
<u>Jane-Jane Lo</u> , Rae-Young Kim, and Raven McCrory	321
<i>Teaching assistants' uses of written curriculum in enacting mathematics lessons for prospective elementary teachers</i>	
Maria-Dolores Lozano	329
<i>Characterising algebraic learning through enactivism</i>	
<u>Fenqjen Luo</u> , Jane-Jane Lo, and Yuh-Chyn Leu	337
<i>Taiwanese and U.S. prospective elementary teachers' fundamental knowledge of fractions</i>	
<u>Emá Mamede</u> and Terezinha Nunes	345
<i>Building on children's informal knowledge in the teaching of fractions</i>	
<u>Ami Mamolo</u> and Rina Zazkis	353
<i>Paradox as a lens for exploring notions of infinity</i>	
<u>Michael Meagher</u> and Andrew Brantlinger	361
<i>Mathematics instruction in high needs NYC middle schools</i>	
<u>Vilma Mesa</u> and Peichin Chang	367
<i>Instructors' language in two undergraduate mathematics classrooms</i>	
Nikolaos Metaxas	375
<i>Exemplification in teaching calculus</i>	

Michael Meyer	383
<i>Abduction - a tool for analysing students' ideas</i>	
Christina Misailidou	391
<i>Assessing and developing pedagogical content knowledge: A new approach</i>	
<u>Marta Molina</u> , Encarnación Castro, and Enrique Castro	399
<i>Third graders' strategies and use of relational thinking when solving number sentences</i>	
Deborah Moore-Russo	407
<i>Use of definition construction to help teachers develop the concept of slope</i>	
Eduardo Mosqueda and <u>Kip Téllez</u>	415
<i>Teachers' attributions of language proficiency, mathematics achievement, and school context measures: an exploratory study</i>	
<u>Nicholas G. Mousoulides</u> and Lyn D. English	423
<i>Modelling with data in Cypriot and Australian primary classrooms</i>	
Author Index	431





**Research Reports**  
**Fer - Mou**



# IMPLICATIVE ANALYSIS OF STRATEGIES IN SOLVING PROPORTIONAL AND NONPROPORTIONAL PROBLEMS

Ceneida Fernández, Salvador Llinares, and Julia Valls

University of Alicante

*The purpose of this study is to examine the implicative relationship among students' strategies while solving proportional and nonproportional problems. We used the computer software CHIC to carry out an implicative statistical analysis of the strategies used in different types of problems. Our analysis showed that the use of some strategies was linked to characteristics of the problem, as the context and the type of relationship between numbers in the situation. The implicative analysis generated four implicative structures according to the types of problems and the students' correct strategies. Furthermore, we found that using the rule of three in a proportional task implies the use of this method in nonproportional situations, and the use of the additive strategy in a nonproportional problem implies the use of this in proportional situations.*

## OBJECTIVES AND BACKGROUND

Proportional reasoning involves an understanding of the multiplicative relationship that exists among the quantities that represents the proportional situation, the ability to solve a variety of problems types and the ability to discriminate proportional from nonproportional situations (Cramer et al., 1993; Fernández, 2001). There are three different types of tasks that research has used to assess proportionality reasoning: missing value, numerical comparison and qualitative prediction and comparison (Post et al., 1988; Heller et al., 1990). In missing-value problems three quantities are given and the fourth quantity is unknown while in numerical comparison problems, the rates are given and they only have to be compared. On the other hand, qualitative prediction and comparison problems require comparisons not dependent on specific numerical value. With regard to nonproportional problems, researchers have analyzed various types of structure among the accounts: additive, linear and constant problems. In the constant tasks, the student doesn't have to do any calculations to find the correct solution. The answer is one of the numbers mentioned in the problem itself. In the additive problems the relationship within the ratios is computed by subtracting one term from a second, and then the difference is applied to the other ratio. Finally, in linear tasks, the relationship between the numbers is of the form  $f(x)=ax+b$  whereas in proportional problems, the relationship is of the form  $f(x)=ax$  (Van Dooren et al., 2005).

Researchers have found that problem context and the nature of the numerical relationships influence problem difficulty level and the strategy used (Steinthorsdottir, 2006). Some factors are associated with the nature of the numerical relationships: the presence or absence of integer ratios, the size of the ratios or the numbers used, the

placement of the unknown number and the presence or absence of a repeated difference between the measurement used. Otherwise, important context variables are whether the referential content is discrete or continuous and whether the context is familiar to the student or not (Tourniaire & Pulos, 1985; Misalidou & Williams, 2003; Steinhorsdottir, 2006).

The research has also provided us students' strategies used for solving missing-value problems: unit-rate, factor of change, rule of three and the building-up method (Christou & Philippou, 2002; Tourniaire & Pulos, 1985; Cramer & Post, 1993; Bart et al., 1994). On the other hand, if children want to be successful in nonproportional problems, they have to identify the nonproportional situation. Based on the literature, the additive method is the most common incorrect strategy. In this one, the relationship within the ratios is computed by subtracting one term from another, and then the difference is applied to the second ratio to find the unknown (Tourniaire & Pulos, 1985, Misalidou & Philippou, 2002).

Many studies have provided categorize tasks and categorization systems of strategies. The purpose of this study is to extent previous work about proportional reasoning, examining the implicative relationships among the strategies used by secondary school students while solving proportional and nonproportional problems. The four types of problems that we have considered were missing-value proportional problems, numerical comparison problems, prediction qualitative problems and nonproportional problems. Furthermore, we have investigated if the nature of the numerical relationship and the context influence in the generation of these implicative relationships. We have also analyzed both correct and incorrect strategies used by students in their attempt to solve proportional and nonproportional problems in order to identify evolving levels of sophistication in proportional reasoning.

## **METHOD**

The participants were 135 students in their 1st year of Secondary School from four different schools (12 and 13 years old). There was approximately the same number of female and male students.

A questionnaire with 7 problems was used to collect the data. Students had 55 minutes to complete this questionnaire. Calculators were provided and they were encouraged to record their procedure and to justify their answers. The problems were:

1. In a greengrocer's, 5 kg. of potatoes cost 2 euros. You want to buy 8 kg. How much will they cost? How many kg. will you buy with 5 euros? Explain your results.
2. If Sara mixed less chocolate with more milk than she did yesterday, the milk would taste a)stronger cocoa b)weaker cocoa c)Exactly the same or d)Not enough information to tell. Explain your answer (Modified version, Cramer & Post, 1993).
3. A group of 5 musicians plays a piece of music in 10 minutes. Another group of 35 musicians will play the same piece of music tomorrow. How long will it take this group to play it? Why? (Van Dooren et al. 2005).

4. Marta and Sofia want to paint their rooms exactly the same color. Marta uses 3 cans of yellow paint and 6 cans of red paint. Sofia uses 7 cans of yellow paint. How much red paint does Sofia need? (Misalidou & Williams 2003).
5. Which vehicle has a faster average speed, a truck that covers 100 km. in  $1\frac{1}{2}$  hours or a car that travels 120 km. in  $1\frac{3}{4}$  hours? (Modified version. Lamon, 1999b).
6. Victor and Ana are running around a track. They run equally fast but Ana started later. When Ana has run 5 rounds, Victor has run 15 rounds. When Ana has run 30 rounds, how many has Victor run? Explain your answer (Van Dooren et al. 2005).
7. A company usually sends 9 men to install a security system in an office building, and they do it in about 96 minutes. Today, they have only three men to do the same size job. How much time should be scheduled to complete the job? (Lamon, 1999a).

Tasks 1, 4 and 7 are missing-value proportional problems. Task 2 is a qualitative prediction proportional problem. Task 3 and 6 are nonproportional problems and task 5 is a numerical comparison proportional problem.

Some students were selected to participate in individual clinical interviews and these were videotaped. The interviews were based on the questionnaire questions and the students' replies. The objective of interview was to obtain clarifications and justifications of the students' responses.

## **ANALYSIS**

Data were analyzed from several perspectives: accuracy of solution and solution strategy employed. For each task, the solving process was analyzed to identify the correct and incorrect answers and the type of strategy used. We compiled a list of strategies recorded for each task. We then examined strategies for evidence of overlap and when necessary consolidated overlapping codes was generated. Final coding categories of strategies and respective frequencies are in tables 3 and 4. We identified six correct strategies: unit-rate, building-up method, rule of three, identify the rate-compare, identify the nonproportional situation and factor of change. Furthermore, we identified eight incorrect strategies. All variables were codified as 0 and 1. Therefore, each correct solution was assigned the score of 1, while each wrong solution was given the score of 0. In a similar way, the use of a particular strategy in a problem was codified as 1 and the non use as 0.

For the analysis of the data, we used the computer software CHIC to carry out an implicative statistical analysis (Gras et al., 1997). From this analysis an implicative diagram was derived and it involves relationships between students' responses and relationships among the strategies used.

## **RESULTS**

We have studied the difficulty level of the tasks. We have divided the number of correct answers by the total number of participants. We classified the tasks using intervals difficulty (table I). Tasks 1b, 3, 4, 5 and 7 are difficult. Task 1a has medium

difficulty, task 6 is easy and task 2 is very easy. The table 2 displays correct and incorrect answers percentage.

<b>Difficulty Level</b>	<b>Index difficulty</b>	<b>Tasks</b>
<b>Very difficult</b>	<0.25	E1b,E3,E5,E7 E1a E6 E2
<b>Difficult</b>	0.25to 0.44	
<b>Medium difficulty</b>	0.45to0.54	
<b>Easy</b>	0.55to0.74	
<b>Very easy</b>	>0.74	

Table 1. Difficulty level of the tasks

<b>Problem</b>	<b>Correct Answers %</b>	<b>Incorrect Answers %</b>	<b>Empty Answers %</b>
<b>1a</b>	48	24	28
<b>1b</b>	41	18	41
<b>2</b>	79	16	5
<b>3</b>	41	44	15
<b>4</b>	25	64	11
<b>5</b>	39	37	24
<b>6</b>	57	29	14
<b>7</b>	30	39	31

Table 2. Correct and Incorrect answers percentage

Task 2 had 79% correct answers, so it was the easiest problem for the students. Task 6, 57% and task 1a, 48%. The rest of the items had a percentage in correct answers below 48. The problem with more empty answers was 1b, followed by the problem 7 (students didn't try to solve), but the problem with the biggest number of incorrect answers was the problem 4 (students tried to solve it but without success). To interpret this data we have to observe the characteristics of each problem. Problem 1 has a familiar context to the student and although the numbers are integers, the ratios are nonintegers. The difference between item 1a and 1b is due to placement of the unknown amount. Item 4 hasn't a familiar context but the numbers and the ratios are integers. Although problems 1a and 4 are both missing-value problems and the second has integer numbers and ratios, the first had more correct answers. It could be explained because of the familiarity of the context (buying vs. paint). The task 7 has integer numbers and ratios but it is an inverse proportional problem. The nonproportional problems (3 and 6) had also different difficulty level and were approached in a different way although empty answers were very similar in the two problems (the problem 3 had 15 empty answers and the problem 6 had 14). The difference in the success can be explained by the numerical structure of the situation.

The problem 6 (running) has an additive relationship ( $15-5= 10$ ) that indicates the constant difference between the two runners, while in the problem 3 (musicians) there isn't this structure.

To summarize, students were more successful in the qualitative problem, and then in nonproportional tasks. The list continues with missing-value proportional problems but in a familiar context and with the numerical comparison problems. Finally, missing-value problems but in a non familiar context and in an inverse proportional situation were the most difficult problems.

In tables 3 and 4 we can observe the correct and incorrect strategies and their percentages in each task. The percentages in the table are calculated on the whole number of replies (135). The students used several strategies (correct or incorrect) in some problems, but the use of several correct strategies was only in the missing-value proportional problems (problem 1, 4 and 7). The most commonly used methods by students in solving missing-value proportional problems were the rate-unit, the factor of change, the rule of three and building-up. In the case of the numerical comparison and prediction qualitative problems, students identified the rates and compared them, and with nonproportional problems, they identified the nonproportional situation (Table 3).

Problem	Unit-rate (CSa) %	Building-up method (CSb) %	Rule of three (CSc) %	Identify the rate, compare (CSd) %	Identify the nonproportional situation (CSe) %	Factor of change (CSf) %
1a	31	7	14	-	-	-
1b	12	15	14	-	-	-
2	-	-	-	37	-	-
3	-	-	-	-	41	-
4	3	-	4	-	-	18
5	-	-	-	9	-	-
6	-	-	-	-	60	-
7	-	-	11	-	-	21

Table 3. Correct strategies percentages in the tasks

Problem	Confuse relationship between measures (ISa) %	Incorrect building-up method (ISb) %	Try to identify the rate (ISd) %	Identify rate but its use is incomplete (ISE) %	No rate identification (ISf) %	Use proportionality in a nonproportional situation (ISg) %	Other strategies in a nonproportional situation (ISh) %	Use direct proportionality in an inverse situation (ISi) %	Any Strategy %
1a	4	4	-	-	-	-	-	-	40
1b	2	1	-	-	-	-	-	-	56
2	-	-	-	1	47	-	-	-	15
3	-	-	-	-	-	33	-	-	26
4	-	-	-	3	53	-	-	-	19
5	-	-	4	-	26	-	-	-	61
6	-	-	-	-	-	17	2	-	21
7	1	-	-	-	1	-	-	18	48

Table 4. Incorrect strategies percentages in the tasks

The incorrect strategies used in missing-value proportional problems were (Table 4): confusing the relationship between measures, incorrect building-up method, no rate identification (use the additive strategy) and use direct proportionality in an inverse



situation; And in numerical comparison and prediction qualitative problems, no rate identification, they identified the rate but its use was unsuccessful and tried to identify the rate. With regard to nonproportional problems, students used proportionality. The remaining percentage (any strategy) is completed with empty responses, answers without sense and answers without any explanation or notes about the process followed.

Figure 1 is the implicative graphic (95% level of significance) that involves the responses and correct strategies used. Implicative analysis generated four implicative structures among students' strategies. One of the implicative structures integrated the empty answers (Wi).

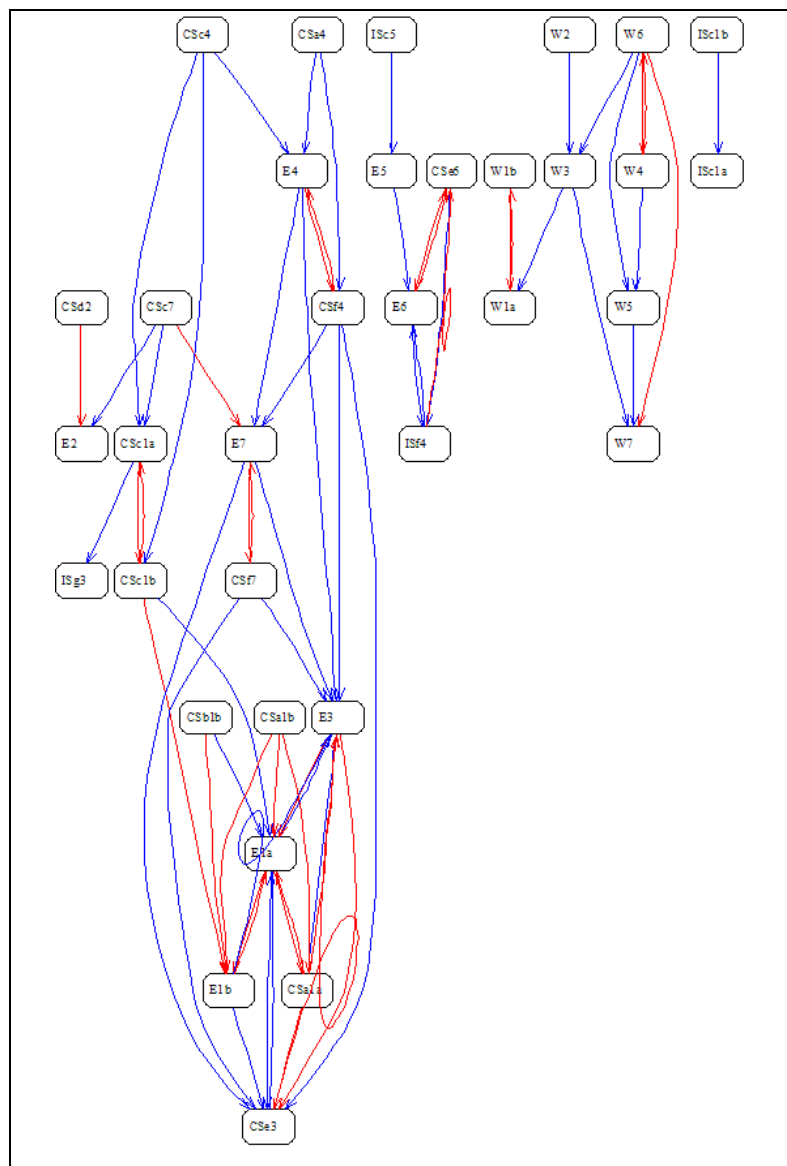

Figure 1. Graphic Implicative<sup>1</sup>.

<sup>1</sup> **Legende:** CS= correct strategies. CSa 4= Unit- Rate in problem 4; CSb 1b = Building-up method in problem 1b; CSa4= Rule of three in problem 4; CSf 4 = factor of change in problem 4. IS= Incorrect strategies. Wi (i=1a,1b,2,3,4,5,6,7) empty responses. Ei (i=1a,1b,2,3,4,5,6,7) Correct response

Some of the implicative relationships identified are the following. If students give an empty answer to task 2 (qualitative prediction) (students don't try to solve the problem), they also make this for task 3 (nonproportional situation) and then for tasks 1a and 1b (missing-value proportional problem, context: buying). Furthermore, an empty answer to task 3 (nonproportional situation, musicians) implies one empty answer to task 7 (missing-value proportional problem, inverse). Otherwise, if they give an empty answer to task 6 (nonproportional situation, runners), they do this to tasks 3 (nonproportional situation, musicians), task 4 (missing-value proportional problem, paint), 5 (comparison proportional problem) and 7 (missing-value proportional problem, inverse) too. These results are related to the difficult level and the students' success in solving tasks.

In the first and the second implicative structures, if students were successful in task 5 (comparison proportional problem), they also were successful in exercise 6 (nonproportional problem, runner). Also if they were successful in task 4 (missing-value problem, paint) they also were successful in tasks 7 (missing-value proportional problem, inverse) and 3 (non proportional, musicians) and then in task 1 (missing-value proportional problem, buying).

Addition to, the use of the unit-rate, rule of three and building-up method entails successful solution in the first problem, the use of the unit-rate, rule of three and factor of change in the fourth problem and the use of rule of three and the factor of change in the seventh task. An explanation of the difference in the strategies in each task could be the different nature of the numerical relationship and the context. Furthermore when students identify the nonproportional situation, they provide a correct answer. Finally, identifying the rates and comparing them implies a correct answer in prediction qualitative problems.

Using the rule of three in missing value proportional problem (paint)(Csc4) implies the use of the same method in problem 1 (missing-value proportional problem, buying). It also implies the use of this rule in a nonproportional situation (Isg3).

## **DISCUSSION AND CONCLUSIONS**

The purpose of this study was to investigate the relationships among students' strategies while solving different types of proportional and nonproportional problems. The analysis of the data reveals that in a missing-value problem with a familiar context and noninteger ratios, the most commonly strategy is the unit-rate (Csa). Our results are according with Christou & Philippou (2002) who concluded the students' tendency to rely on the unit-rate method (they worked with fifth and fourth grade students), but when the ratios are integers they prefer to use the factor of change. Also, in task 4 (proportional problem), 53% of the students didn't identify the rate (Isf) and used an additive strategy. Misalidou & Williams (2003) identified that the additive strategy was the dominant erroneous strategy and they obtained that a lot of students used this strategy in this type of task. Another result is the tendency to use a proportional strategy in a nonproportional situation according with Van Dooren et al. (2005).

Concerning the existence of a relationship between strategies, using the rule of three in a missing-value problem (CSc1a or CSc1b) implies the use of the same strategy in other missing-value problems (1b or 1a, 4) and also in nonproportional situations (ISg3).

Finally, we underline the large percentages of erroneous strategies revealing that students in their first year of Secondary School don't understand the multiplicative relationship among quantities in a proportional situation and they have difficulty to differentiate between a proportional situation and nonproportional situation.

## References

- Christou, C. & Philippou, G. (2002). Mapping and development of intuitive proportional thinking. *Journal of Mathematical Behaviour*, 20, 321-336.
- Cramer, K., Post, T., & Currier, S. (1993). Learning and Teaching Ratio and Proportion: Research Implications. In D. Owens (Ed.), *Research Ideas For the Classroom* (pp. 159-178). NY: Macmillan Publishing Company.
- Fernández, A. (2001). Precursores del razonamiento proporcional: un estudio con alumnos de primaria. *Tesis Doctoral Inédita*. Departamento de Didáctica de las Matemáticas. Universidad de Valencia.
- Gras R., Peter P., & Philippe J. (1997). Implicative statistical analysis. *Proceedings of IFCS 96*, Tokyo: Springer-Verlag.
- Heller, P., Ahlgren, A., Post, T., Behr, M., & Lesh, R. (1989). Proportional Reasoning: The effect of two context variables, Rate Type and Problem Setting. *Journal for Research in Science Teaching*, 26(1), 205-220.
- Lamon, S. (1999). *Teaching Fractions and Ratios for Understanding*. Lawrence Erlbaum Associates.
- Misailidou, C. & Williams, J. (2003). Diagnostic assessment of children's proportional reasoning. *Journal of Mathematical Behavior*, 22, 335-368.
- Steinthorsdottir, O. B. (2006). Proportional reasoning: variable influencing the problems difficulty level and one's use of problem solving strategies. *Proceedings of the 30<sup>th</sup> PME International Conference*, 5, 169-176.
- Van Dooren, W., De Bock, D., Hessels, A., D. Janssens, & L. Verschaffel, L. (2005). Not everything is proportional: Effects of Age and Problem Type on Propensities of Overgeneralization. *Cognition and Instruction* 23(1), 57-86.
- Van Dooren, W., De Bock, D., Evers, M., & Verschaffel, L. (2006). Pupils' over-use of proportionality on missing-value problems: How numbers may change solutions. *Proceedings of the 30<sup>th</sup> PME International Conference*, 5, 305-312.

# COGNITIVE TENDENCIES AND GENERATING MEANING IN THE ACQUISITION OF ALGEBRAIC SUBSTITUTION AND COMPARISON METHODS

Eugenio Filloy, Teresa Rojano, and Armando Solares  
Cinvestav

*We studied the progress of algebraic syntax, once students have overcome the initial obstacles of the transition toward symbolic algebra. We analyzed the progress on the line of operation of the unknown, but when said unknown is represented by an expression involving a second unknown. One of the first times in the curriculum that this situation arises is when students learn the methods used to solve two-unknown linear equation systems. During the process of acquiring such methods, the cognitive tendencies identified in operation of a single unknown reappear (Filloy and Rojano 1989) and the need to re-elaborate the notion of algebraic equality becomes patent.*

The transition processes involved in moving to algebraic thought have attracted the attention of many researchers dealing with the didactics of algebra. Studies such as those carried out by C. Kieran (1981), E. Filloy and T. Rojano (1989), R. Herscovicks and L. Linchevsky (1991), A. Sfard and L. Linchevsky (1994), K. Stacey and M. MacGregor (1997), A. Gallardo (2002) and J. Vlasiss (2002), inter alia, have provided evidence to the effect that said transition involves profound changes in the mathematical thoughts of students. This research report broaches the topic of progressing in algebraic syntax, once students have overcome the first obstacles inherent in the transition toward symbolic algebra. We have specifically analyzed that progress on the line of the study *Operating the Unknown* (Filloy and Rojano, 1989), when the unknown is represented by an expression that involves a second unknown. One of the first times in a curriculum that this situation appears is when classic algebraic methods for solution of systems with two linear equations with two unknowns are introduced: the substitution and comparison methods.

In the two-unknown two-linear equation system:  $y = 2x + 3$ ;  $y = 4x + 1$ , the student will have to operate the unknowns with “second level” representations. That is to say, in the example provided above in addition to being represented by a letter (the  $y$ ) unknown  $y$  is also represented by an expression that involves the other unknown (the  $x$ ). In the process of acquiring the new algebraic syntax, the cognitive tendencies identified in operation of a single unknown reappear (Filloy and Rojano, 1989; Filloy, 1991). In this research report, we will show that essential elements of algebraic representation must be reconstructed in order to acquire the sense of use of the methods of substitution and comparison (Filloy, Rojano and Solares, 2003; Filloy, Rojano & Puig, 2007, pp. 27-57).

## **THEORETICAL FRAMEWORK**

The theoretical perspective adopted for this study was that of *Local Theoretical Models* (Kieran & Filloy, 1989; Filloy, Rojano, & Puig, 2007). According to said

perspective, we determined the essential components of teaching and learning methods for solving equation systems: the *Teaching Model*; the *Cognitive Processes Model*, through which learning processes are interpreted; the *Formal Competence Model*, which describes formal mathematical knowledge dealing with equation systems; and the *Communication Model*, by way of which message exchanges undertaken by the subjects are interpreted. This paper deals specifically with the components of the Formal Competence Model and the Cognitive Processes Model.

The Formal Model designed made it possible to define the transformations and meanings involved in applying the comparison and substitution methods. The list of transformations was defined based on the algebraic syntax work of D. Kirshner (1987), which deals with symbolic algebraic language. From Kirshner's work, we incorporated the generation of *simple algebraic expressions* (additions, subtractions, multiplications, divisions and number and literal exponentiation) and the list of their *transformations* (the rules of associativity, commutativity, distributivity and multiplication and factorization of quadratic polynomials), which enable simplification of numerical operations and algebraic expressions. We added *single-unknown linear equations* and *two-unknown linear equation systems* to the expressions generated by Kirshner. We moreover added classic algebraic transformations that make it possible to operate the unknown in equations and systems: *Transposition and Cancellation* of terms, for single-unknown linear equations; and *Substitution and Equalization* of expressions for two-unknown two-linear equation systems. With respect to the theoretical elements of semantics, we took up the notions of *Sinn* (sense) and of *Bedeutung* (reference) as developed by G. Frege (1996) for the case of *names*. In an equation of the  $y = Ax + B$  type, expression  $Ax + B$  can be considered a "name" for the unknown. The *reference* for the latter expression results from its numerical value (unknown), while its *sense* is the mode in which that numerical value is expressed. In other words, it is the "chain of operations" that must be made in order to find the resulting value (For more information concerning this Formal Model, please see Rojano, 2005).

In the study *Operating the Unknown* (Filloy and Rojano, 1989), several cognitive tendencies were identified and characterized in student productions during their initial contact with operating unknowns. The set of these cognitive tendencies constitutes a model for the cognitive processes of this study. The following are several of the cognitive tendencies we identified: the return to more concrete situations when an analysis situation arises; focusing on readings made at language levels that will not enable solving the problem situation; and the presence of semantics-derived obstructions on syntax, and vice versa (Filloy & Rojano, 1989; Filloy, 1991; Filloy, Rojano, & Puig, 2007, pp. 163-189).

## THE EXPERIMENTAL DESIGN

Clinical interviews were carried out with 12 secondary school students (aged 13 to 15). The students had been introduced to elementary algebra on the topic of solving single-unknown linear equations, but had not yet been taught how to solve equation systems. We chose seven students who systematically used the algebraic transformations of

# TABLE OF CONTENTS

## VOLUME 3

### Research Reports

<u>Ceneida Fernández</u> , Salvador Llinares, and Julia Valls <i>Implicative analysis of strategies in solving proportional and nonproportional problems</i>	1-8
Eugenio Filloy, Teresa Rojano, and <u>Armando Solares</u> <i>Cognitive tendencies and generating meaning in the acquisition of algebraic substitution and comparison methods</i>	9-16
<u>Vicenç Font</u> and <u>Núria Planas</u> <i>Mathematical practices, semiotic conflicts, and socio-mathematical norms</i>	17-23
Helen J. Forgasz <i>Gender, socio-economic status, and mathematics performance among high achievers</i>	25-32
<u>Cristina Frade</u> and Milene Carneiro Machado <i>Culture and affect: Influences of the teachers' values on students' affect</i>	33-40
John Francisco <i>Mathematical beliefs and behaviors of high school students: Insights from a case study</i>	41-48
<u>Anne Berit Fuglestad</u> and Simon Goodchild <i>Affordances of inquiry: The case of one teacher</i>	49-56
Susan Gerofsky <i>Gesture as diagnosis and intervention in the pedagogy of graphing: Pilot studies and next steps</i>	57-64
<u>Hope Gerson</u> and Janet G. Walter <i>Building connected understanding of calculus</i>	65-71
Camilla Gilmore and <u>Matthew Inglis</u> <i>Process- and object-based thinking in arithmetic</i>	73-80
<u>Pedro Gómez</u> , María J. González, Luis Rico, and José L. Lupiáñez <i>Learning the notion of learning goal in an initial functional training program</i>	81-88

Alejandro S. González-Martín, <u>Fernando Hitt</u> , and Christian Morasse	89-96
<i>The introduction of the graphic representation of functions through the concept of co-variation and spontaneous representations. A case study</i>	
Eddie Gray and <u>Maria Doritou</u>	97-104
<i>The number line: Ambiguity and interpretation</i>	
<u>Roxana Grigoraş</u> and Stefan Halverscheid	105-112
<i>Modelling the travelling salesman problem: Relations between the world of mathematics and the rest of the world</i>	
Markus Hähkiöniemi	113-120
<i>Durability and meaningfulness of mathematical knowledge - the case of the derivative concept</i>	
Stefan Halverscheid	121-128
<i>How pre-service teachers use experiments for understanding the circular billiard</i>	
Mathias Hattermann	129-136
<i>The dragging process in three dimensional dynamic geometry environments (DGE)</i>	
<u>Lulu Healy</u> and Hassan Solange Ahmad Ali Fernandes	137-144
<i>The role of gestures in the mathematical practices of blind learners</i>	
<u>Aiso Heinze</u> and Frank Lipowsky	145-152
<i>Informal strategy use for addition and subtraction of three-digit numbers: Accuracy and adaptivity of German 3<sup>rd</sup>-graders</i>	
Beth Herbel-Eisenmann, <u>David Wagner</u> , and Viviana Cortes	153-160
<i>Encoding authority: Pervasive lexical bundles in mathematics classrooms</i>	
Paul Hernandez-Martinez	161-168
<i>Institutional practices and the mathematical identity of undergraduates</i>	
<u>Kate Highfield</u> , Joanne Mulligan, and John Hedberg	169-176
<i>Early mathematics learning through exploration with programable toys</i>	
<u>Marj Horne</u> and Kelly Watson	177-184
<i>Developing understanding of triangle</i>	

<u>Anesa Hosein</u> , James Aczel, Doug Clow, and John T.E. Richardson	185-192
<i>Comparison of black-box, glass-box and open-box software for aiding conceptual understanding</i>	
<u>Jodie Hunter</u> and Glenda Anthony	193-200
<i>Developing relational thinking in an inquiry environment</i>	
Roberta Hunter	201-208
<i>Do they know what to ask and why? Teachers shifting student questioning from explaining to justifying and generalising reasoning</i>	
<u>Bat-Sheva Ilany</u> and Bruria Margolin	209-216
<i>Textual literacy in mathematics- an instructional model</i>	
Matthew Inglis and <u>Adrian Simpson</u>	217-224
<i>Reasoning from features or exemplars</i>	
<u>Sonia Jones</u> and Howard Tanner	225-232
<i>Reflective discourse and the effective teaching of numeracy</i>	
Leslie H. Kahn, <u>Sandra I. Musanti</u> , Laura Kondek McLeman, José María Menéndez-Gómez, and <u>Barbara Trujillo</u>	233-240
<i>Teachers of latino students reflect on the implementation of a mathematical task</i>	
Karen Allen Keene	241-248
<i>Ways of reasoning: Two case studies in an inquiry-oriented differential equations class</i>	
<u>Carolyn Kieran</u> , José Guzmán, A. Boileau, D. Tanguay, and P. Drijvers	249-256
<i>Orchestrating whole-class discussions in algebra with the aid of CAS technology</i>	
<u>Andrea Knapp</u> , Megan Bommer, and Cynthia Moore	257-263
<i>Lesson study as a learning environment for mathematics coaches</i>	
<u>Karen Koellner</u> and Jennifer Jacobs	265-272
<i>Fostering instructional change through mathematics professional development: Focusing on teachers' self-selected goals</i>	
Boris Koichu	273-280
<i>On considerations of parsimony in mathematical problem solving</i>	



<u>Heidi Krzywacki-Vainio</u> and Markku S. Hannula	281-288
<i>Development of mathematics teacher students' teacher identity during teaching practice</i>	
Sebastian Kuntze	289-296
<i>Fostering geometrical proof competency by student-centred writing activities</i>	
<u>Paul Ngee-Kiong Lau</u> and Tee-Yong Hwa	297-304
<i>Mathematics constructions in an interactive classroom context</i>	
Henry Leppäaho	305-312
<i>The problem solving MAP method: A tool for mathematical problem solving</i>	
<u>Hee-Chan Lew</u> and Kum-Nam So	313-320
<i>Two justification processes in solving algebraic problem using graphing technology</i>	
<u>Jane-Jane Lo</u> , Rae-Young Kim, and Raven McCrory	321-328
<i>Teaching assistants' uses of written curriculum in enacting mathematics lessons for prospective elementary teachers</i>	
Maria-Dolores Lozano	329-336
<i>Characterising algebraic learning through enactivism</i>	
<u>Fenqjen Luo</u> , Jane-Jane Lo, and Yuh-Chyn Leu	337-344
<i>Taiwanese and U.S. prospective elementary teachers' fundamental knowledge of fractions</i>	
<u>Emá Mamede</u> and Terezinha Nunes	345-352
<i>Building on children's informal knowledge in the teaching of fractions</i>	
<u>Ami Mamolo</u> and Rina Zazkis	353-360
<i>Paradox as a lens for exploring notions of infinity</i>	
<u>Michael Meagher</u> and Andrew Brantlinger	361-365
<i>Mathematics instruction in high needs NYC middle schools</i>	
<u>Vilma Mesa</u> and Peichin Chang	367-374
<i>Instructors' language in two undergraduate mathematics classrooms</i>	
Nikolaos Metaxas	375-382
<i>Exemplification in teaching calculus</i>	

Michael Meyer	383-390
<i>Abduction - a tool for analysing students' ideas</i>	
Christina Misailidou	391-398
<i>Assessing and developing pedagogical content knowledge: A new approach</i>	
<u>Marta Molina</u> , Encarnación Castro, and Enrique Castro	399-406
<i>Third graders' strategies and use of relational thinking when solving number sentences</i>	
Deborah Moore-Russo	407-414
<i>Use of definition construction to help teachers develop the concept of slope</i>	
Eduardo Mosqueda and <u>Kip Téllez</u>	415-421
<i>Teachers' attributions of language proficiency, mathematics achievement, and school context measures: an exploratory study</i>	
<u>Nicholas G. Mousoulides</u> and Lyn D. English	423-430
<i>Modelling with data in Cypriot and Australian primary classrooms</i>	
Author Index	431-432



**Research Reports**  
**Fer - Mou**



# IMPLICATIVE ANALYSIS OF STRATEGIES IN SOLVING PROPORTIONAL AND NONPROPORTIONAL PROBLEMS

Ceneida Fernández, Salvador Llinares, and Julia Valls

University of Alicante

*The purpose of this study is to examine the implicative relationship among students' strategies while solving proportional and nonproportional problems. We used the computer software CHIC to carry out an implicative statistical analysis of the strategies used in different types of problems. Our analysis showed that the use of some strategies was linked to characteristics of the problem, as the context and the type of relationship between numbers in the situation. The implicative analysis generated four implicative structures according to the types of problems and the students' correct strategies. Furthermore, we found that using the rule of three in a proportional task implies the use of this method in nonproportional situations, and the use of the additive strategy in a nonproportional problem implies the use of this in proportional situations.*

## OBJECTIVES AND BACKGROUND

Proportional reasoning involves an understanding of the multiplicative relationship that exists among the quantities that represents the proportional situation, the ability to solve a variety of problems types and the ability to discriminate proportional from nonproportional situations (Cramer et al., 1993; Fernández, 2001). There are three different types of tasks that research has used to assess proportionality reasoning: missing value, numerical comparison and qualitative prediction and comparison (Post et al., 1988; Heller et al., 1990). In missing-value problems three quantities are given and the fourth quantity is unknown while in numerical comparison problems, the rates are given and they only have to be compared. On the other hand, qualitative prediction and comparison problems require comparisons not dependent on specific numerical value. With regard to nonproportional problems, researchers have analyzed various types of structure among the accounts: additive, linear and constant problems. In the constant tasks, the student doesn't have to do any calculations to find the correct solution. The answer is one of the numbers mentioned in the problem itself. In the additive problems the relationship within the ratios is computed by subtracting one term from a second, and then the difference is applied to the other ratio. Finally, in linear tasks, the relationship between the numbers is of the form  $f(x)=ax+b$  whereas in proportional problems, the relationship is of the form  $f(x)=ax$  (Van Dooren et al., 2005).

Researchers have found that problem context and the nature of the numerical relationships influence problem difficulty level and the strategy used (Steinthorsdottir, 2006). Some factors are associated with the nature of the numerical relationships: the presence or absence of integer ratios, the size of the ratios or the numbers used, the

placement of the unknown number and the presence or absence of a repeated difference between the measurement used. Otherwise, important context variables are whether the referential content is discrete or continuous and whether the context is familiar to the student or not (Tourniaire & Pulos, 1985; Misalidou & Williams, 2003; Steinhorsdottir, 2006).

The research has also provided us students' strategies used for solving missing-value problems: unit-rate, factor of change, rule of three and the building-up method (Christou & Philippou, 2002; Tourniaire & Pulos, 1985; Cramer & Post, 1993; Bart et al., 1994). On the other hand, if children want to be successful in nonproportional problems, they have to identify the nonproportional situation. Based on the literature, the additive method is the most common incorrect strategy. In this one, the relationship within the ratios is computed by subtracting one term from another, and then the difference is applied to the second ratio to find the unknown (Tourniaire & Pulos, 1985, Misalidou & Philippou, 2002).

Many studies have provided categorize tasks and categorization systems of strategies. The purpose of this study is to extent previous work about proportional reasoning, examining the implicative relationships among the strategies used by secondary school students while solving proportional and nonproportional problems. The four types of problems that we have considered were missing-value proportional problems, numerical comparison problems, prediction qualitative problems and nonproportional problems. Furthermore, we have investigated if the nature of the numerical relationship and the context influence in the generation of these implicative relationships. We have also analyzed both correct and incorrect strategies used by students in their attempt to solve proportional and nonproportional problems in order to identify evolving levels of sophistication in proportional reasoning.

## **METHOD**

The participants were 135 students in their 1st year of Secondary School from four different schools (12 and 13 years old). There was approximately the same number of female and male students.

A questionnaire with 7 problems was used to collect the data. Students had 55 minutes to complete this questionnaire. Calculators were provided and they were encouraged to record their procedure and to justify their answers. The problems were:

1. In a greengrocer's, 5 kg. of potatoes cost 2 euros. You want to buy 8 kg. How much will they cost? How many kg. will you buy with 5 euros? Explain your results.
2. If Sara mixed less chocolate with more milk than she did yesterday, the milk would taste a)stronger cocoa b)weaker cocoa c)Exactly the same or d)Not enough information to tell. Explain your answer (Modified version, Cramer & Post, 1993).
3. A group of 5 musicians plays a piece of music in 10 minutes. Another group of 35 musicians will play the same piece of music tomorrow. How long will it take this group to play it? Why? (Van Dooren et al. 2005).

4. Marta and Sofia want to paint their rooms exactly the same color. Marta uses 3 cans of yellow paint and 6 cans of red paint. Sofia uses 7 cans of yellow paint. How much red paint does Sofia need? (Misalidou & Williams 2003).
5. Which vehicle has a faster average speed, a truck that covers 100 km. in  $1\frac{1}{2}$  hours or a car that travels 120 km. in  $1\frac{3}{4}$  hours? (Modified version. Lamon, 1999b).
6. Victor and Ana are running around a track. They run equally fast but Ana started later. When Ana has run 5 rounds, Victor has run 15 rounds. When Ana has run 30 rounds, how many has Victor run? Explain your answer (Van Dooren et al. 2005).
7. A company usually sends 9 men to install a security system in an office building, and they do it in about 96 minutes. Today, they have only three men to do the same size job. How much time should be scheduled to complete the job? (Lamon, 1999a).

Tasks 1, 4 and 7 are missing-value proportional problems. Task 2 is a qualitative prediction proportional problem. Task 3 and 6 are nonproportional problems and task 5 is a numerical comparison proportional problem.

Some students were selected to participate in individual clinical interviews and these were videotaped. The interviews were based on the questionnaire questions and the students' replies. The objective of interview was to obtain clarifications and justifications of the students' responses.

## **ANALYSIS**

Data were analyzed from several perspectives: accuracy of solution and solution strategy employed. For each task, the solving process was analyzed to identify the correct and incorrect answers and the type of strategy used. We compiled a list of strategies recorded for each task. We then examined strategies for evidence of overlap and when necessary consolidated overlapping codes was generated. Final coding categories of strategies and respective frequencies are in tables 3 and 4. We identified six correct strategies: unit-rate, building-up method, rule of three, identify the rate-compare, identify the nonproportional situation and factor of change. Furthermore, we identified eight incorrect strategies. All variables were codified as 0 and 1. Therefore, each correct solution was assigned the score of 1, while each wrong solution was given the score of 0. In a similar way, the use of a particular strategy in a problem was codified as 1 and the non use as 0.

For the analysis of the data, we used the computer software CHIC to carry out an implicative statistical analysis (Gras et al., 1997). From this analysis an implicative diagram was derived and it involves relationships between students' responses and relationships among the strategies used.

## **RESULTS**

We have studied the difficulty level of the tasks. We have divided the number of correct answers by the total number of participants. We classified the tasks using intervals difficulty (table I). Tasks 1b, 3, 4, 5 and 7 are difficult. Task 1a has medium



difficulty, task 6 is easy and task 2 is very easy. The table 2 displays correct and incorrect answers percentage.

<b>Difficulty Level</b>	<b>Index difficulty</b>	<b>Tasks</b>
<b>Very difficult</b>	<0.25	E1b,E3,E5,E7 E1a E6 E2
<b>Difficult</b>	0.25to 0.44	
<b>Medium difficulty</b>	0.45to0.54	
<b>Easy</b>	0.55to0.74	
<b>Very easy</b>	>0.74	

Table 1. Difficulty level of the tasks

<b>Problem</b>	<b>Correct Answers %</b>	<b>Incorrect Answers %</b>	<b>Empty Answers %</b>
<b>1a</b>	48	24	28
<b>1b</b>	41	18	41
<b>2</b>	79	16	5
<b>3</b>	41	44	15
<b>4</b>	25	64	11
<b>5</b>	39	37	24
<b>6</b>	57	29	14
<b>7</b>	30	39	31

Table 2. Correct and Incorrect answers percentage

Task 2 had 79% correct answers, so it was the easiest problem for the students. Task 6, 57% and task 1a, 48%. The rest of the items had a percentage in correct answers below 48. The problem with more empty answers was 1b, followed by the problem 7 (students didn't try to solve), but the problem with the biggest number of incorrect answers was the problem 4 (students tried to solve it but without success). To interpret this data we have to observe the characteristics of each problem. Problem 1 has a familiar context to the student and although the numbers are integers, the ratios are nonintegers. The difference between item 1a and 1b is due to placement of the unknown amount. Item 4 hasn't a familiar context but the numbers and the ratios are integers. Although problems 1a and 4 are both missing-value problems and the second has integer numbers and ratios, the first had more correct answers. It could be explained because of the familiarity of the context (buying vs. paint). The task 7 has integer numbers and ratios but it is an inverse proportional problem. The nonproportional problems (3 and 6) had also different difficulty level and were approached in a different way although empty answers were very similar in the two problems (the problem 3 had 15 empty answers and the problem 6 had 14). The difference in the success can be explained by the numerical structure of the situation.

The problem 6 (running) has an additive relationship ( $15-5= 10$ ) that indicates the constant difference between the two runners, while in the problem 3 (musicians) there isn't this structure.

To summarize, students were more successful in the qualitative problem, and then in nonproportional tasks. The list continues with missing-value proportional problems but in a familiar context and with the numerical comparison problems. Finally, missing-value problems but in a non familiar context and in an inverse proportional situation were the most difficult problems.

In tables 3 and 4 we can observe the correct and incorrect strategies and their percentages in each task. The percentages in the table are calculated on the whole number of replies (135). The students used several strategies (correct or incorrect) in some problems, but the use of several correct strategies was only in the missing-value proportional problems (problem 1, 4 and 7). The most commonly used methods by students in solving missing-value proportional problems were the rate-unit, the factor of change, the rule of three and building-up. In the case of the numerical comparison and prediction qualitative problems, students identified the rates and compared them, and with nonproportional problems, they identified the nonproportional situation (Table 3).

Problem	Unit-rate (CSa) %	Building-up method (CSb) %	Rule of three (CSc) %	Identify the rate, compare (CSd) %	Identify the nonproportional situation (CSe) %	Factor of change (CSf) %
1a	31	7	14	-	-	-
1b	12	15	14	-	-	-
2	-	-	-	37	-	-
3	-	-	-	-	41	-
4	3	-	4	-	-	18
5	-	-	-	9	-	-
6	-	-	-	-	60	-
7	-	-	11	-	-	21

Table 3. Correct strategies percentages in the tasks

Problem	Confuse relationship between measures (ISa) %	Incorrect building-up method (ISb) %	Try to identify the rate (ISd) %	Identify rate but its use is incomplete (ISE) %	No rate identification (ISf) %	Use proportionality in a nonproportional situation (ISg) %	Other strategies in a nonproportional situation (ISh) %	Use direct proportionality in an inverse situation (ISi) %	Any Strategy %
1a	4	4	-	-	-	-	-	-	40
1b	2	1	-	-	-	-	-	-	56
2	-	-	-	1	47	-	-	-	15
3	-	-	-	-	-	33	-	-	26
4	-	-	-	3	53	-	-	-	19
5	-	-	4	-	26	-	-	-	61
6	-	-	-	-	-	17	2	-	21
7	1	-	-	-	1	-	-	18	48

Table 4. Incorrect strategies percentages in the tasks

The incorrect strategies used in missing-value proportional problems were (Table 4): confusing the relationship between measures, incorrect building-up method, no rate identification (use the additive strategy) and use direct proportionality in an inverse

situation; And in numerical comparison and prediction qualitative problems, no rate identification, they identified the rate but its use was unsuccessful and tried to identify the rate. With regard to nonproportional problems, students used proportionality. The remaining percentage (any strategy) is completed with empty responses, answers without sense and answers without any explanation or notes about the process followed.

Figure 1 is the implicative graphic (95% level of significance) that involves the responses and correct strategies used. Implicative analysis generated four implicative structures among students' strategies. One of the implicative structures integrated the empty answers (Wi).

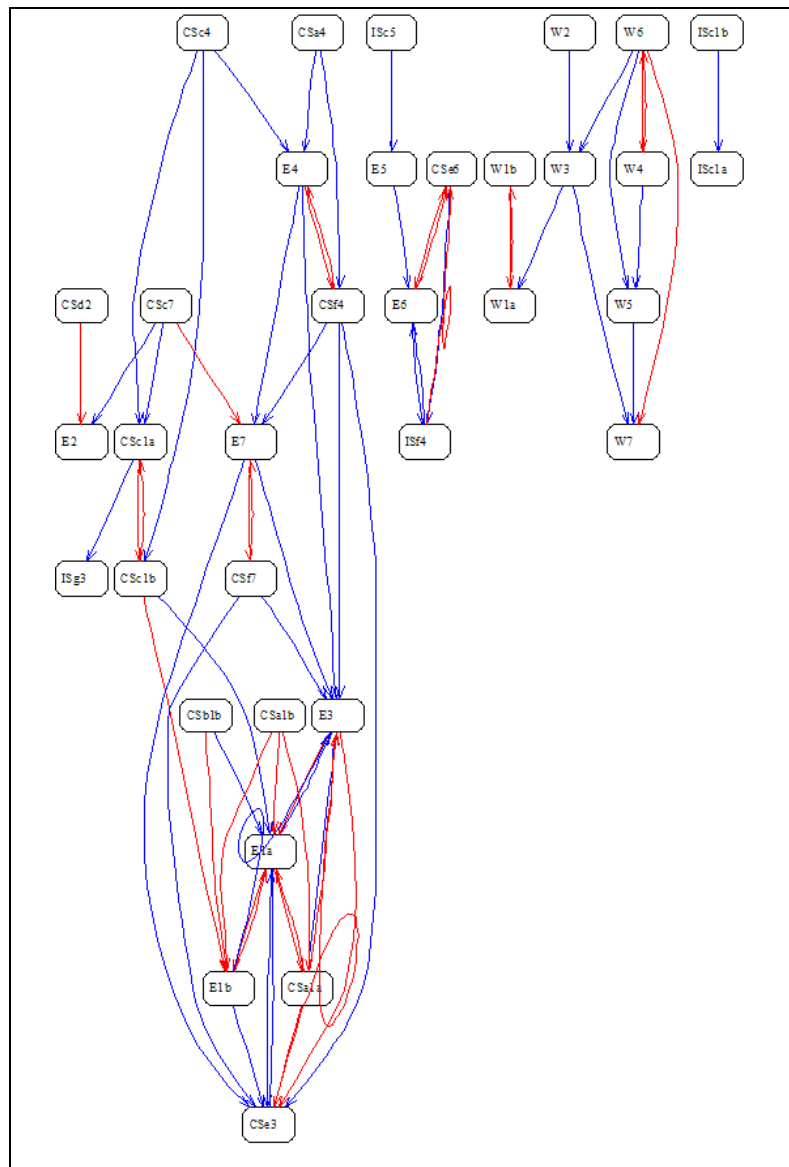

Figure 1. Graphic Implicative<sup>1</sup>.

<sup>1</sup> **Legende:** CS= correct strategies. CSa 4= Unit- Rate in problem 4; CSb 1b = Building-up method in problem 1b; CSa4= Rule of three in problem 4; CSf 4 = factor of change in problem 4. IS= Incorrect strategies. Wi (i=1a,1b,2,3,4,5,6,7) empty responses. Ei (i=1a,1b,2,3,4,5,6,7) Correct response

Some of the implicative relationships identified are the following. If students give an empty answer to task 2 (qualitative prediction) (students don't try to solve the problem), they also make this for task 3 (nonproportional situation) and then for tasks 1a and 1b (missing-value proportional problem, context: buying). Furthermore, an empty answer to task 3 (nonproportional situation, musicians) implies one empty answer to task 7 (missing-value proportional problem, inverse). Otherwise, if they give an empty answer to task 6 (nonproportional situation, runners), they do this to tasks 3 (nonproportional situation, musicians), task 4 (missing-value proportional problem, paint), 5 (comparison proportional problem) and 7 (missing-value proportional problem, inverse) too. These results are related to the difficult level and the students' success in solving tasks.

In the first and the second implicative structures, if students were successful in task 5 (comparison proportional problem), they also were successful in exercise 6 (nonproportional problem, runner). Also if they were successful in task 4 (missing-value problem, paint) they also were successful in tasks 7 (missing-value proportional problem, inverse) and 3 (non proportional, musicians) and then in task 1 (missing-value proportional problem, buying).

Addition to, the use of the unit-rate, rule of three and building-up method entails successful solution in the first problem, the use of the unit-rate, rule of three and factor of change in the fourth problem and the use of rule of three and the factor of change in the seventh task. An explanation of the difference in the strategies in each task could be the different nature of the numerical relationship and the context. Furthermore when students identify the nonproportional situation, they provide a correct answer. Finally, identifying the rates and comparing them implies a correct answer in prediction qualitative problems.

Using the rule of three in missing value proportional problem (paint)(Csc4) implies the use of the same method in problem 1 (missing-value proportional problem, buying). It also implies the use of this rule in a nonproportional situation (Isg3).

## **DISCUSSION AND CONCLUSIONS**

The purpose of this study was to investigate the relationships among students' strategies while solving different types of proportional and nonproportional problems. The analysis of the data reveals that in a missing-value problem with a familiar context and noninteger ratios, the most commonly strategy is the unit-rate (Csa). Our results are according with Christou & Philippou (2002) who concluded the students' tendency to rely on the unit-rate method (they worked with fifth and fourth grade students), but when the ratios are integers they prefer to use the factor of change. Also, in task 4 (proportional problem), 53% of the students didn't identify the rate (Isf) and used an additive strategy. Misalidou & Williams (2003) identified that the additive strategy was the dominant erroneous strategy and they obtained that a lot of students used this strategy in this type of task. Another result is the tendency to use a proportional strategy in a nonproportional situation according with Van Dooren et al. (2005).

Concerning the existence of a relationship between strategies, using the rule of three in a missing-value problem (CSc1a or CSc1b) implies the use of the same strategy in other missing-value problems (1b or 1a, 4) and also in nonproportional situations (ISg3).

Finally, we underline the large percentages of erroneous strategies revealing that students in their first year of Secondary School don't understand the multiplicative relationship among quantities in a proportional situation and they have difficulty to differentiate between a proportional situation and nonproportional situation.

## References

- Christou, C. & Philippou, G. (2002). Mapping and development of intuitive proportional thinking. *Journal of Mathematical Behaviour*, 20, 321-336.
- Cramer, K., Post, T., & Currier, S. (1993). Learning and Teaching Ratio and Proportion: Research Implications. In D. Owens (Ed.), *Research Ideas For the Classroom* (pp. 159-178). NY: Macmillan Publishing Company.
- Fernández, A. (2001). Precursores del razonamiento proporcional: un estudio con alumnos de primaria. *Tesis Doctoral Inédita*. Departamento de Didáctica de las Matemáticas. Universidad de Valencia.
- Gras R., Peter P., & Philippe J. (1997). Implicative statistical analysis. *Proceedings of IFCS 96*, Tokyo: Springer-Verlag.
- Heller, P., Ahlgren, A., Post, T., Behr, M., & Lesh, R. (1989). Proportional Reasoning: The effect of two context variables, Rate Type and Problem Setting. *Journal for Research in Science Teaching*, 26(1), 205-220.
- Lamon, S. (1999). *Teaching Fractions and Ratios for Understanding*. Lawrence Erlbaum Associates.
- Misailidou, C. & Williams, J. (2003). Diagnostic assessment of children's proportional reasoning. *Journal of Mathematical Behavior*, 22, 335-368.
- Steinthorsdottir, O. B. (2006). Proportional reasoning: variable influencing the problems difficulty level and one's use of problem solving strategies. *Proceedings of the 30<sup>th</sup> PME International Conference*, 5, 169-176.
- Van Dooren, W., De Bock, D., Hessels, A., D. Janssens, & L. Verschaffel, L. (2005). Not everything is proportional: Effects of Age and Problem Type on Propensities of Overgeneralization. *Cognition and Instruction* 23(1), 57-86.
- Van Dooren, W., De Bock, D., Evers, M., & Verschaffel, L. (2006). Pupils' over-use of proportionality on missing-value problems: How numbers may change solutions. *Proceedings of the 30<sup>th</sup> PME International Conference*, 5, 305-312.

# COGNITIVE TENDENCIES AND GENERATING MEANING IN THE ACQUISITION OF ALGEBRAIC SUBSTITUTION AND COMPARISON METHODS

Eugenio Filloy, Teresa Rojano, and Armando Solares  
Cinvestav

*We studied the progress of algebraic syntax, once students have overcome the initial obstacles of the transition toward symbolic algebra. We analyzed the progress on the line of operation of the unknown, but when said unknown is represented by an expression involving a second unknown. One of the first times in the curriculum that this situation arises is when students learn the methods used to solve two-unknown linear equation systems. During the process of acquiring such methods, the cognitive tendencies identified in operation of a single unknown reappear (Filloy and Rojano 1989) and the need to re-elaborate the notion of algebraic equality becomes patent.*

The transition processes involved in moving to algebraic thought have attracted the attention of many researchers dealing with the didactics of algebra. Studies such as those carried out by C. Kieran (1981), E. Filloy and T. Rojano (1989), R. Herscovicks and L. Linchevsky (1991), A. Sfard and L. Linchevsky (1994), K. Stacey and M. MacGregor (1997), A. Gallardo (2002) and J. Vlasiss (2002), inter alia, have provided evidence to the effect that said transition involves profound changes in the mathematical thoughts of students. This research report broaches the topic of progressing in algebraic syntax, once students have overcome the first obstacles inherent in the transition toward symbolic algebra. We have specifically analyzed that progress on the line of the study *Operating the Unknown* (Filloy and Rojano, 1989), when the unknown is represented by an expression that involves a second unknown. One of the first times in a curriculum that this situation appears is when classic algebraic methods for solution of systems with two linear equations with two unknowns are introduced: the substitution and comparison methods.

In the two-unknown two-linear equation system:  $y = 2x + 3$ ;  $y = 4x + 1$ , the student will have to operate the unknowns with “second level” representations. That is to say, in the example provided above in addition to being represented by a letter (the  $y$ ) unknown  $y$  is also represented by an expression that involves the other unknown (the  $x$ ). In the process of acquiring the new algebraic syntax, the cognitive tendencies identified in operation of a single unknown reappear (Filloy and Rojano, 1989; Filloy, 1991). In this research report, we will show that essential elements of algebraic representation must be reconstructed in order to acquire the sense of use of the methods of substitution and comparison (Filloy, Rojano and Solares, 2003; Filloy, Rojano & Puig, 2007, pp. 27-57).

## THEORETICAL FRAMEWORK

The theoretical perspective adopted for this study was that of *Local Theoretical Models* (Kieran & Filloy, 1989; Filloy, Rojano, & Puig, 2007). According to said

perspective, we determined the essential components of teaching and learning methods for solving equation systems: the *Teaching Model*; the *Cognitive Processes Model*, through which learning processes are interpreted; the *Formal Competence Model*, which describes formal mathematical knowledge dealing with equation systems; and the *Communication Model*, by way of which message exchanges undertaken by the subjects are interpreted. This paper deals specifically with the components of the Formal Competence Model and the Cognitive Processes Model.

The Formal Model designed made it possible to define the transformations and meanings involved in applying the comparison and substitution methods. The list of transformations was defined based on the algebraic syntax work of D. Kirshner (1987), which deals with symbolic algebraic language. From Kirshner's work, we incorporated the generation of *simple algebraic expressions* (additions, subtractions, multiplications, divisions and number and literal exponentiation) and the list of their *transformations* (the rules of associativity, commutativity, distributivity and multiplication and factorization of quadratic polynomials), which enable simplification of numerical operations and algebraic expressions. We added *single-unknown linear equations* and *two-unknown linear equation systems* to the expressions generated by Kirshner. We moreover added classic algebraic transformations that make it possible to operate the unknown in equations and systems: *Transposition and Cancellation* of terms, for single-unknown linear equations; and *Substitution and Equalization* of expressions for two-unknown two-linear equation systems. With respect to the theoretical elements of semantics, we took up the notions of *Sinn* (sense) and of *Bedeutung* (reference) as developed by G. Frege (1996) for the case of *names*. In an equation of the  $y = Ax + B$  type, expression  $Ax + B$  can be considered a "name" for the unknown. The *reference* for the latter expression results from its numerical value (unknown), while its *sense* is the mode in which that numerical value is expressed. In other words, it is the "chain of operations" that must be made in order to find the resulting value (For more information concerning this Formal Model, please see Rojano, 2005).

In the study *Operating the Unknown* (Filloy and Rojano, 1989), several cognitive tendencies were identified and characterized in student productions during their initial contact with operating unknowns. The set of these cognitive tendencies constitutes a model for the cognitive processes of this study. The following are several of the cognitive tendencies we identified: the return to more concrete situations when an analysis situation arises; focusing on readings made at language levels that will not enable solving the problem situation; and the presence of semantics-derived obstructions on syntax, and vice versa (Filloy & Rojano, 1989; Filloy, 1991; Filloy, Rojano, & Puig, 2007, pp. 163-189).

## THE EXPERIMENTAL DESIGN

Clinical interviews were carried out with 12 secondary school students (aged 13 to 15). The students had been introduced to elementary algebra on the topic of solving single-unknown linear equations, but had not yet been taught how to solve equation systems. We chose seven students who systematically used the algebraic transformations of

*Transposition* or *Cancellation* of terms in order to solve single-unknown equations. We also selected another five students who had not yet consolidated their knowledge of algebraic syntax for operation of single-unknown equations, but who did have a high level of competence in numerical calculation and systematically used arithmetic strategies, such as *Trial and Error*, in order to solve single-unknown equations.

The interview script was designed based on an analysis undertaken within the Formal Model of the comparison and substitution methods. The different transformations applied to solving a two-unknown two-linear equation system are introduced in the script in order to take student knowledge to its very “limits”. That is to say, once understanding of the problem of finding a solution to an equation system is guaranteed, their knowledge is taken to a point at which that knowledge is no longer sufficient enough for the students to solve the systems presented. Variation of the numerical domains of the solutions (natural numbers, decimals, fractions, positives and negatives) and of the syntactic structures of the equations generate “obstructions” in the interpretation and operation of the different expressions of the unknown. *Equalization* and *Substitution* were introduced as the means of operating the unknown in this new level of representation. Table 1 shows the list of items presented. Solutions are presented as  $(x, y)$ .

$y = 4x + 2; 2x + 6 = y$ (2, 10)	$4y - 1 = x; 2y + 7 = x$ (15, 4)	$x = 5y; x = 54 - y$ (45, 9)	$y = 2x; 5x + 3 = y$ (-1, -2)
$x = 5y + 1; x = \frac{3y - 1}{3}$ (-2/3, -1/3)	$x = y + 1; x + y = 11$ (6, 5)	$x = 5y; x + y = 54$ (45, 9)	$y = 5x; y - 25x = 100$ (-5, -25)
$4x - 3 = y; 6x = y - 7$ (-5, -23)	$2x + 3y = 72; 3y = x$ (24, 8)	$x = 6y + 3; 3x + 6 = 6y - 12$ (-3/2, -9/4)	$3x + y = 14; x + y = 10$ (2, 8)

Table 1. List of items presented

## RESULTS OF INTERVIEW ANALYSIS

### Returning to more concrete levels and focusing on positive integers

In general terms and without significant differences between application of either the substitution or the comparison method, the students made use of *more concrete levels* than algebraic levels in order to operate the unknowns while solving the new problems. Their preferred spontaneous strategy was *Trial and Error* -applied by nine of the 12 students interviewed.

As the interview progressed, the variation of solution numerical domain generated great difficulties. The cognitive tendency to place themselves at more concrete levels became more acute. In spite of their high numerical competences (including operations with negative numbers), four students assumed that there would only be positive solutions and reached the conclusion that in systems of the type  $[y = 2x;$



$5x + 3 = y$ ], the numerical values of the expression  $5x + 3$  would always be bigger than the numerical values of the expression  $2x$ . For instance, one of the students interviewed, Circe (C), sought the values of the unknowns in the following manner: (The letter I indicates the Interviewer).

C: It's just that it doesn't work, because [points to the system:  $y = 2x$ ;  $5x + 3 = y$ ], if the  $y$  is worth two  $x$  [points to  $2x$ ], it cannot be worth five  $x$  plus three [points to  $5x + 3$ ].

I: Why not?

C: If it's worth two  $x$  [points to  $2x$ ], five  $x$  plus three [points to  $5x + 3$ ] will always be bigger than two  $x$  [points to  $2x$ ].

I: Always?

C: Yes.

I: Let's see. Why do you say that this [points to equation  $5x + 3 = y$ ] will be greater than this [points to  $y = 2x$ ]?

C: Well, because five  $x$  [points to  $5x$ ] will always be bigger than two  $x$  [points to  $2x$ ].

I: Uh-huh. What about negative numbers?

C: With negative numbers too. [She stops, while looking at the paper and remains silent]

$$y = 2(-1)$$

$$y = -2$$

C: It does work with negative numbers. Yes, five minus one, plus three is equal to minus two... [Writes]

$$5(-1) + 3 = -2$$

$$y = 2(-1)$$

$$y = -2 // 5(-1) + 3 = -2$$

$$-5 + 3 = -2$$

$$-2 = -2$$

C:  $y$  is worth... [Writes]

$$y = -2$$

$$x = -1$$

In this case, *focusing on the domain of positive numbers* for looking for the solutions of the equations and making the operations (additions, subtractions, multiplications and divisions) prevented Circe from finding the solution. At that point it became necessary to broaden the numerical domain by incorporating negative numbers. This need to broaden the numerical domain became necessary for the majority of the students interviewed.

### The presence of syntax-derived obstructions

Five students demonstrated a *non-symmetrical interpretation of equality*. During the process of solving a system of the type [ $y = Ax + B$ ;  $y = Cx + D$ ], for example, using the comparison method, the expressions  $Ax + B$  and  $Cx + D$  are equalized, and reduced equation  $Ax + B = Cx + D$  is obtained. The non-symmetry mistake consists

of changing the sign in expression  $Ax + B$ , since it goes from being located on the right-hand side of the equal sign [in  $y = Ax + B$ ] to the left-hand side [in  $Ax + B = Cx + D$ ]. Let us take a look at non-symmetry in the case of Ana (A).

- I: I have a question. One of your classmates was saying “this x, x [points to x in  $x = 5y$ ] is equal to five y, and that x [points to x in  $x = 54 - y$ ] is equal to fifty-four minus y”, so, like you, he said “this [points to  $5y$ ] must be equal to this [points to  $54 - y$ ]”, right? And he wrote down the equality, but, but your classmate said “be careful with the signs! This five y [points to  $5y$  in  $x = 5y$ ] is on the right-hand side and here [points to the x in  $x = 54 - y$ ] we’re going to put it on the left-hand side”. Like you, right? [I points to the equation obtained from the equalization:  $5y = 54 - y$ ]. “We’re going to put it on the left-hand side and since it’s going to change sides, the sign has to change...”
- A: [Interrupts] To negative!
- I: What do you think?
- A: Yes.
- I: Yes? Well, how would you do it?
- A: [Writes]  
 $-5y = 54 -$
- A: Fifty-four minus y?
- I: What?
- A: Yes, don’t you think?... Yes [completes the equation].  
 $-5y = 54 - y$
- I: So that’s how you would do it then?
- A: I just change the sign.
- I: What sign?
- A: The one for the five.

The error arises when *Transposition* of terms is applied in an over generalized manner to a case in which it is not an unknown that is being operated, rather it is a matter of an *Equalization* of expressions. Transposition is a transformation undertaken in order to operate an unknown within an equation, whereas the new transformation -the *Equalization*- is a transformation of equation systems that results in a single-unknown equation. The error corresponds to the cognitive tendency of *obstructions derived from previously learned syntax*. It was also found in the solutions obtained using the substitution method.

### **The presence of semantics-derived obstructions and the need to broaden the notion of algebraic equality**

In three of the 12 cases, readings that were focused on the domain of positive solutions led to the manifestation of another cognitive tendency related to the analysis of the syntactic structure of the expressions (the *superficial structures*, following the work of D. Kirshner, 1987). While solving the system [ $y = 2x$ ;  $5x + 3 = y$ ] by applying the comparison method, the students stated that the expressions could indeed be equal “because they are x signs, it’s like if it was a five, two times x [ $2x$ ]

and... five times  $x$  [ $5x + 3$ ]", but "with the plus sign it doesn't work anymore... because plus three is yet another operation [referring to "+ 3" in  $5x + 3$ ]... it gives another number". For instance Raúl (R) stated the following:

- R: I think you can't do this one.
- I: You can't do it? Well, explain why not to me again.
- R: It's that it's adding times three, I mean it's adding three in addition to the five times  $x$ , that's bigger than the two.
- I: You told me that you had tried with... big numbers, with decimals too, with fractions. Have you tried it with negative numbers? You did one with minus three, right? How about with minus two?
- R: No, this would be too big [points to the equation  $5x + 3 = y$ ] and this one would be too small [points to the equation  $y = 2x$ ].
- I: And we were saying: This  $y$  is equal to this  $y$  [points to the  $y$ s in the two equations]. This  $x$  is equal to this  $x$  [points to the  $x$ s in the two equations], right? It says "y is equal to two x", right? [Points out in the equation  $y = 2x$ ]. And the  $y$  is equal to this [points to the equation  $5x + 3 = y$ ]. What I was asking you is: Do you think it's true that this is equal to this? [Points to  $5x + 3$  in the equation  $5x + 3 = y$  and points to  $2x$  in the equation  $y = 2x$ ].
- R: Not any more, not with the plus sign.
- I: Not any more? Why not?
- R: Because plus three is another operation altogether.
- R: It gives another number.

In Raúl's case, focusing on positive numbers generated conflicts surrounding the notion of equality: two expressions with different syntactic structures could not be *equalized*. In this conflict, the tendency of *presence of numerical semantics-derived obstructions* is manifested.

Generally speaking, manifestation of the cognitive tendencies described attests to the conflicts faced by students at this time of transition, moving from representation of one unknown to representation of an unknown given in terms of another unknown. Students have to operate different types of equalities and unknown representations. Let us now see how Carlos (Ca) does in his attempts to solve the system [ $x = 5y$ ,  $x = 54 - y$ ].

- I: I have a question for you, Carlos. Well... one of your classmates the other day was saying the following: "this  $x$  [points to  $x$  in the first equation of the system under way  $x = 5y$ ] is equal to this  $x$ " [points to  $x$  in the second equation of the system:  $x = 54 - y$ ]. Do you agree with that?
- Ca: Uh-huh. [Nods].
- I: And he was saying "this  $y$  [points to  $y$  in  $x = 5y$ ] is equal to this  $y$ " [points to  $y$  in  $x = 54 - y$ ].
- Ca: Uh-huh... [He's not convinced].
- I: Right?
- Ca: Here it's five times [points to  $5y$  in  $x = 5y$ ].
- I: Here [points to  $5y$  in  $x = 5y$ ] it's five times ...
- Ca: But here, it's just once [points to  $y$  in  $x = 54 - y$ ].

- I: Here, just once [points to  $y$  in  $x = 54 - y$ ]... And he was saying “since this  $x$  is equal to five  $y$  [points to  $x$  in  $x = 5y$ ] and this  $x$  is equal to fifty-four minus  $y$  [points to  $x$  in  $x = 54 - y$ ] and the two  $x$ s are the same, then... I have”. He said “that five  $y$  is equal to fifty-four minus  $y$ ” [points to  $5y$  in  $x = 5y$ , and points to  $54 - y$  in  $x = 54 - y$ ]. Do you think that’s right?
- Ca: No!
- I: No?
- Ca: No, well no!
- I: Why not?
- Ca: Because this is completely different [points to  $x = 5y$ ] from this [points to “ $- y$ ” in  $x = 54 - y$ ] and from this [points to  $54$  in the equation  $x = 54 - y$ ].
- I: How are they different?
- Ca: In everything, in their values and in everything.
- I: Well... Does it matter that this is equal to this [points to  $x$  in the equation  $x = 5y$ ] and that it says that the same thing [points to  $x$  in the equation  $x = 54 - y$ ] is equal to this? [points to  $54 - y$  in the equation  $x = 54 - y$ ]. It says “ $x$  is equal to five  $y$  [points to the equation  $x = 5y$ ]” and “ $x$  is equal to fifty-four minus  $y$  [points to the equation  $x = 54 - y$ ]”. Are they the same or not?
- Ca: No, well no they’re not.
- I: Right? Then was your classmate right or not?
- Ca: Yes.
- I: Yes?
- Ca: In this [points to  $x$  in the two equations:  $x = 5y$ ,  $x = 54 - y$ ], but not in this [points to “ $5y$ ” and “ $54 - y$ ”].

Two separate interpretations of algebraic equality are present in Carlos’ interpretation. In the system [ $x = 5y$ ,  $x = 54 - y$ ] the value of  $x$  is equal to  $5y$  and, at the same time, it is equal to  $54 - y$ . On the one hand, the *identity* of the representation is present:  $x$  is representing the same unknown value in both equations. Yet on the other hand, the *restricted equality* established between an unknown and the algebraic expression that corresponds to it through the equation is also present. The expressions  $5y$  and  $54 - y$  have the same numerical values, they have equal *references*. But at the same time, the values of those algebraic expressions are referred to in different ways: “Five  $y$  [ $5y$ ] is not the same as fifty-four minus  $y$  [ $54 - y$ ]”. The expressions have different *senses*.

## FINAL REMARKS

The results obtained in this study confirm the presence of the cognitive tendencies found in the study *Operation of the Unknown* (Filloy and Rojano, 1989) in this new level of algebraic representation of the unknown.

In order to acquire competent use of the methods, that is to say, to acquire the *sense of use of the methods* (Filloy, Rojano, & Solares, 2003; Filloy, Rojano, & Puig, 2007, pp. 191-213), essential elements of algebraic representation must necessarily be reconstructed: the *reference* and the *sense* of the different algebraic expressions used to represent unknowns at this new level.

The authors would like to thank: Fondo Sectorial de Investigación para la Educación del CONACyT - for their support through SEP-2003-CO2-44632/A-1 grant; and Centro Escolar Hermanos Revueltas - for cooperation of the teachers, and not lastly, their wonderful students in the development of this project.

## References

- Filloy, E. (1991). Cognitive tendencies and abstraction processes in algebra learning. In Furinghetti (Ed.), *Proceedings of the 5<sup>th</sup> PME*, Vol. 2, 48-56. Assisi, Italy.
- Filloy, E. & Rojano, T. (1985b). Operating the unknown and models of teaching (a clinical study with 12-13 year olds with a high proficiency in pre-algebra). En Damarin, S. K. and Shelton, M. (Ed.), *Proceedings of the 7<sup>th</sup> PME-NA*.
- Filloy, E. & Rojano, T. (1989). Solving equations: The transition from arithmetic to algebra. *For the Learning of Mathematics*, Vol. 9, No. 2, 19-25.
- Filloy, E., Rojano T., & Puig, L. (2007). *Educational Algebra. A Theoretical and Empirical Approach*. Berlin Heidelberg, New York: Springer.
- Filloy, E., Rojano, T., & Solares, A. (2003). Two meanings of the equal sign and senses of substitution and comparison methods. In N. A. Pateman, B. Dogherty, & J. Zilliox (Eds.), *Proceedings of the 27<sup>th</sup> PME*, Vol. 4, pgs. 223-229. Honolulu, Hawaii, USA.
- Gallardo, A. (2002). The extension of the natural-number domain to the integers in the transition from arithmetic to algebra. *Educational Studies in Mathematics*, 49, 171-192.
- Herscovics, R. & Linchevsky, L. (1991). Crossing the didactic cut in algebra: grouping like terms in an equation. In R. G. Underhill (Ed.), *Proceedings of the 13<sup>th</sup> PME-NA*, Vol. 1. 196-202. Blacksburg, Virginia, USA: Division of Curriculum and Instruction, VPI and SU.
- Kieran, C. (1981). Concepts associated with the equality symbol. In *Educational Studies in Mathematics*, Vol. 1, 317-326. USA.
- Kieran, C. & Sfard, A. (1999). Seeing through Symbols: The case of equivalent expressions. In *Focus on Learning Problems in Mathematics*, Vol. 21(1) Center for Teaching/Learning of Mathematics.
- Frege, G. (1996). Sentido y significado. In *Escritos filosóficos* (tr. Mosterín, J.), Crítica: Barcelona.
- Kirshner, D. (1987) *The Grammar of Symbolic Elementary Algebra*. Unpublished doctoral dissertation, University of British Columbia, Vancouver.
- Rojano, T. (2004). Local theoretical models in algebra learning: a meeting point in mathematics education (Plenary lecture). In McDougall, D. E. & Ross, J. A. (Eds.), *Proceedings of the 26<sup>th</sup> PME-NA*, (Vol. 1, pp. 37-53). Toronto, Canada: Ontario Institute for Studies in Education of the University of Toronto.
- Sfard, A. & Linchevski, L. (1994). The gains and pitfalls of reification - the case of algebra. *Educational Studies in Mathematics*, 26, 191-228.
- Stacey, K. & MacGregor, M. (1997). Multiple referents and shifting meanings of unknowns in students' use of algebra. In E. Pehkonen (Ed.), *Proceedings of the 21<sup>st</sup> PME*, (vol. IV, 190-197). Lahti, Finland: PME.
- Vlassis, J. (2002). The balance model: Hindrance or support for the solving of linear equations with one unknown. *Educational Studies in Mathematics*, 49, 341-359.

# MATHEMATICAL PRACTICES, SEMIOTIC CONFLICTS, AND SOCIO-MATHEMATICAL NORMS

Vicenç Font

Universitat de Barcelona

Núria Planas

Universitat Autònoma of Barcelona

*We adapt the onto-semiotic approach to research in mathematics education developed by Godino and his colleagues (e.g., Font, D'Amore & Godino, 2007; Godino, Batanero, & Roa, 2005) in order to better understand certain disparities in the interpretation of classroom socio-mathematical norms (Yackel & Cobb, 1996). In this approach, the experience of disparities in the interpretation of norms can be conceptualized as the experience of semiotic conflicts. We explore semiotic conflicts in the mathematics classroom in relation to: 1) mathematical practices that are being developed within the classroom, 2) socio-mathematical norms that intervene in the orchestration of the practices, and 3) differences in the interpretation of the norms.*

## INTRODUCTION

We build on three theoretical concepts -mathematical practices, semiotic conflicts, and socio-mathematical norms- by looking at relationships among them in the context of the mathematics classroom. We begin with a focus on the notion of mathematical practices as viewed by the onto-semiotic approach to research in mathematics education. We then move to considerations on how this approach helps develop a joint exploration of notions traditionally drawn from different theoretical frameworks, such as semiotic conflicts and socio-mathematical norms. Finally, we present some findings from the analysis of a classroom episode where participants differ in their understanding of certain norms. We argue that the emergence of a semiotic conflict in that episode and its resolution are related to 1) mathematical practices that are being developed within the classroom context, 2) socio-mathematical norms that intervene in the orchestration of the practices, and 3) differences in the interpretation of the norms.

## MATHEMATICAL PRACTICES

The onto-semiotic approach to research in mathematics education (e.g. Font, D'Amore & Godino, 2007; Godino, Batanero, & Roa, 2005; Godino, Batanero, & Font, 2007) tackles the problem of meaning and the representation of knowledge by elaborating a mathematical ontology based on anthropological, semiotic and socio-cultural frameworks. Mathematical knowledge is considered to depend on the cultural institutions and the social contexts where the learner is implied, and on the activities s/he develops there. The mathematical activity plays a central role and is modeled in terms of systems of mathematical practices. Godino and Batanero (1994), in reference to the notion of mathematical practice, write:

We consider *mathematical practice* [sic] any action or manifestation (linguistic or otherwise) carried out by somebody to solve mathematical problems, to communicate the

solution to other people, so as to validate and generalize that solution to other contexts and problems (Godino & Batanero, 1994, p. 182, quoted in Godino, Batanero, & Font, 2007, p. 129).

By focusing on the notion of mathematical practice, the onto-semiotic approach puts the emphasis on the mathematical objects and processes that make this practice possible. Systems of mathematical practices are conformed by different types of mathematical objects (language, arguments, concepts, propositions, procedures, problems...). Here, the notion of meaning is defined in terms of the practices. For instance, the meaning of “equation” can be viewed as the systems of practices where “equations” are required or carried out. The analysis of the systems of practices that lead to the emergence of mathematical objects and processes is, therefore, crucial when trying to infer the meanings for these objects and processes.

The objects that appear in mathematical practices and those emerging from these practices take into account different “dimensions.” In this report, we are especially interested in the personal/institutional dimension that is, in turn, related to different types of mathematical processes. The processes of solving problems or those of modeling are “mega-processes” than can be divided into more primary processes such as those of personalizing and institutionalizing. In the onto-semiotic approach, teaching involves the participation of students in a context of practices where processes of institutionalizing are being developed. Learning is conceived as the students’ personalizing of practices that are (to be) institutionalized.

### **SEMIOTIC CONFLICTS AND SOCIO-MATHEMATICAL NORMS**

The role of the practices is also emphasized by the socio-cultural approach (Stephan, Cobb, & Gravemeijer, 2003). This approach, however, has given priority to other types of processes such as processes of valorization that regulate the access of the learner to the practices in the mathematics classroom. Processes of personalizing and institutionalizing have been mainly explored from the perspective of the personal and the legitimate interpretations given to norms of the mathematical practice. Godino, Batanero and Font (2007) say that “[the notion of mathematical practice] might allow a coherent articulation with other theoretical frameworks [different from the onto-semiotic framework], such as ... [the] socio-cultural approach to mathematical meaning and cognition.” (p. 134).

We attempt to articulate the notion of socio-mathematical norm with that of semiotic conflict. A semiotic conflict is “any disparity or difference of interpretation between the meanings ascribed to an expression by two subjects, being either persons or institutions” (Godino, Batanero, & Font, 2007, p. 133). We refer to socio-mathematical norms as the regulations that influence participation within the mathematics classroom, and the interactive structure of the development of its practices (Yackel, & Cobb, 1996).

We view the diversity of interpretations of socio-mathematical norms from the perspective of the diversity of practices where these norms intervene. In particular, a

norm is a type of object that is especially related to processes of institutionalizing and personalizing. Differences in the interpretation of socio-mathematical norms turn into differences in mathematical practices that intervene in processes of institutionalizing and personalizing. And vice versa, differences in the mathematical practices that intervene in these processes turn into differences in the interpretation of norms.

The experience of differences in the interpretation of norms can be conceptualized as the experience of semiotic conflicts. For instance, the different understanding of a norm such as “working collaboratively when solving a problem” constitutes itself a semiotic conflict when subjects differ in their interpretation of the word “collaboratively” -and therefore carry out different practices in their collaboration with other subjects-, or when they differ in their interpretation of what counts as “communicating when working collaboratively.”

The interpretations of norms are constructed under the influence of at least three issues: 1) the participation in a diversity of contexts of institutional knowledge, 2) the reconstruction of personal expectations, values and other norms, and 3) the interaction with others. The focus on each of these issues leads to three main types of semiotic conflicts: epistemic, cognitive and interactional. Any conflict is to some extent and at the same time, epistemic, cognitive and interactional. A girl may have constructed an interpretation of the expression “working collaboratively” during her participation in a girl scouts group; this may differ from that given by the teacher in her mathematics classroom, and also with that given by her personal reconstructions as a result of knowing the peers with whom she is supposed to “work collaboratively.”

The institutional meaning given to “subtraction algorithm” by a group of Moroccan immigrant students, in a mainstream school where the group of local students has been taught a different algorithm, is an example of epistemic conflict. The mathematical object “subtraction algorithm” can be used differently depending on the contexts of institutional knowledge that have had an influence on the students of each group. This epistemic conflict is linked to the interpretation of the socio-mathematical norm that regulates the subtraction procedure to be used in the classroom. We briefly analyze another example of epistemic conflict in the next section.

Certain contradictory practices can point to a cognitive conflict. A student may properly operate with fractions, but after having studied the equations -where denominators are deleted at a certain stage of the process of solving equations-, s/he may transfer the procedure with equations to operations with fractions. The socio-mathematical norms that regulate operations with fractions and equations are involved in the emergence of this conflict, though there may be other norms involved such as “teaching equations without considering the fractions that ‘constitute’ an equation.”

Interactional conflicts can occur in situations of exchange such as student-student or student-teacher, when participants differ in the interpretation of an expression. A



teacher in a classroom may draw a non-prototypical triangle and refer to it with the word “triangle”, but a student may not recognize the drawing as a triangle because s/he is only used to visualize prototypical examples. What counts as the representation for a triangle -which it itself a socio-mathematical norm- is differently understood by the student and the teacher. Another student’s interpretation of the object “triangle” can be based on the visualization of portions of pizza or traffic signals, which are objects from an “out-of-school” epistemology. The next example refers to an epistemic conflict that is also interactional as it is mainly expressed through confronted linguistic manifestations in the classroom context.

**AN EXAMPLE**

We present an example of semiotic conflict and part of its interpretive analysis by drawing on data from a classroom episode in a high school (15 and 16 years old students). It is the first lesson where the teacher proposes a problem solving dynamics with small-group work during the whole class. The problem is about two well-known neighborhoods near the school site (see Figure 1), whose actual names were given to the students. The episode is centered on the discussion of a particular aspect of the arithmetical task. It starts during the first part of the whole group discussion, when the members of a group, Alicia (A), Emilio (E) and Mateo (M), tell the teacher (T) that they have developed different approaches to the task. The episode finishes when the teacher shifts from exploring this group’s ideas to attempting to make other groups participate. We reproduce part of the transcript, where the semiotic conflict can be inferred. The mathematical practices and the socio-mathematical norms that help understand the conflict are taken from the whole episode’s transcript.

Here you have the population and area of two neighborhoods in your town.

Neighborhood 1 (N1)	Neighborhood 2 (N2)
65,075 inhabitants	190,030 inhabitants
7 km <sup>2</sup>	5 km <sup>2</sup>

(i) Discuss in which of these places people live more spaciouly.  
(ii) Find how many people should move from one neighborhood to the other in order to live in both of them spaciouly.

Figure 1. The statement of the problem

**The conflict**

- [1] A: This is a problem about densities because data are about densities.
- [2] T: OK. Tell Alicia that she needs to explain herself better. [To Alicia] We know that you know a lot, but...
- [3] A: In N1 the density is lower than in N2. That’s all.
- [4] T: Emilio says no.

- [5] E: I just don't see it! There's something missing.
- [6] T: [To Emilio] How have you done it?
- [7] E: It's clear that here [N2] there are more people and less space. I've been there. Flats are very small.
- [8] T: OK. You say it's clear, but then how do you answer the second question? You cannot say again that flats are very small.
- [9] E: The second question is wrong.
- [10] T: Why?
- [11] E: I wouldn't move alone, I'd take all my family.
- [12] T: What do you mean?
- [13] E: I would change the second question.
- [14] T: Don't start again, Emilio! You know that problems are like they are.

The semiotic conflict occurs when the teacher tells Emilio that the reasoning used when answering (i) will not be useful when trying to answer (ii) [8]. For Emilio, the first question of the problem is rather obvious, given his knowledge of the neighborhoods. The teacher's comment does not make him change his approach. Instead of developing a "more mathematical" reasoning or a reasoning less based on his knowledge of the neighborhoods, and despite the teacher's requirement, the student maintains an argument based on his "out-of-school" knowledge [11]. During the group work (which is not part of the transcript we discuss), Emilio had made similar comments showing him connecting the problem to his "out-of-school" knowledge.

Later the teacher centers his efforts on the process of institutionalizing Alicia's approach to the problem. This student introduces almost all the mathematical practices during the episode by properly using symbolic and verbal mathematical languages, constructing arguments ("This is a problem about densities", "In N1 the density is lower than in N2", "9,296 is smaller than this number [38,006]...), referring to mathematical concepts ("fractions", "equations", "decimals"...), introducing mathematical procedures ("dividing", "comparing densities", "solving equations"...), and establishing relationships among these objects in various propositions. Most of Alicia's mathematical practices are represented on the blackboard, such as that of changing 65,075 to 65,072 [23] (see transcript below). She removes 3 people from the original number of people because she wants the property of working with a multiple of 7 and not having decimal numbers.

Alicia also develops the practice of solving "contextualized" mathematical problems. The teacher points to the importance of the process of going back and forth between the "mathematical context" and the "real context" when solving a problem whose statement is based on "real life." The situation in which the problem happens and that helps to understand its solution -the "real context"- must be referred to at certain stages of the solving process. However, Emilio does not accept moving from his knowledge of the neighborhoods to the mathematical knowledge that he is expected

to have. Alicia shows more flexibility. After having listened to one of the teacher's comments [24], she moves to the "real context" suggested by the statement of the problem, and later she goes back to the "mathematical context" again.

During the episode, two socio-mathematical norms explicitly regulate the practice of solving "contextualized" mathematical problems:

*Norm 1:* At the end of the solving process, the solution must be interpreted within the real context suggested by the problem.

[23] A: [On the blackboard]

$$\frac{65,075}{7} \rightarrow \frac{65,072}{7} = 9,296 \text{ h/km}^2 \text{ at N1}$$

$$\frac{190,030}{5} = 38,006 \text{ h/km}^2 \text{ at N2; } 9,296 < 38,006$$

[24] T: OK. We need to compare the two neighborhoods. These numbers mean nothing if we don't compare them.

[25] A: This number [9,296] is...

[26] E: We place some people here and some people there.

[27] A: Let me finish! 9,296 is smaller than this number [38,006]. This means that in N1 you live more spaciouly.

[28] T: OK.

*Norm 2:* At a certain stage of the solving process, the mathematical context must prevail over the real context.

[38] T: Mateo, let's concentrate, now you forget about the people and you only think about the fraction. Is 65,075 a multiple of 7?

[39] M: No.

[40] T: That's the point! 65,072 is a multiple of 7 and 65,075 isn't. Now it can be divided exactly.

[41] M: But it's not about multiples, it's about people!

Emilio does not adjust to these norms, neither during the experience of the conflict nor during the teacher's comments that follow this experience. By using his "out-of-school" knowledge, Emilio resorts to his understanding of an appropriate way of solving "contextualized" problems in the mathematics classroom. He insists on interpreting the solving process in the real context that is suggested by the statement of the problem. Alicia suggests a process of generalization when she repeatedly considers that the problem is a particular case of a certain type of problems -problems about density- [1, 3, and later in the transcript]. Emilio, however, refuses to accept this argument. He also refuses the process of idealization that the teacher wants Mateo to carry out when he wants this student to focus on the fraction and its representation on the blackboard [38].

We interpret that the conflict has to do with how to determine the valid methods of solving "contextualized" mathematical problems when they seem to be different

whether being applied in a real life context or in the institutional context of the mathematics classroom [9-13]. Although the teacher points to an important meta-epistemic norm of the mathematics classroom [14], makes two socio-mathematical norms explicit, and leads Alicia to develop rather good mathematical practices, Emilio insists for a while on using his “out-of-school” knowledge and shows a certain resistance towards the institutional meanings defended by the teacher. At the end of the episode, Emilio finally accepts copying the equation in his notebook and gives up on his attempts to change the approach to the problem for the rest of the session. Here, the resolution of the epistemic conflict must be understood as the public act of not insisting on the importance of the “out-of-school” knowledge anymore.

## FINAL REMARKS

Some of the teacher’s initial efforts when trying to make Emilio experience a cognitive conflictive [8] do not seem to be directly related to this student’s sudden change in his positioning. Despite the identification of some possible issues of influence for this change to occur, how firmly can we affirm that Emilio’s experience of a conflict has been solved? Is it possible to modify a positioning concerning which knowledge is appropriate in a mathematics classroom only by listening to a few norms and paying attention to some good mathematical processes? What if changes in Emilio’s discourse seek to improve his relationship with Alicia and with the teacher, and do not express conviction? Is Emilio publicly acknowledging practices that he does not own? The onto-semiotic approach helps explore experiences of semiotic conflicts and issues of influence on the public resolution of these conflicts from the perspective of the practices and the norms involved. But we still need to better understand how learners experience others’ interpretations of socio-mathematical norms and mathematical practices.

## References

- Font, V., D’Amore, B., & Godino, J. D. (2007). An onto-semiotic approach to representations in mathematics education. *For the Learning of Mathematics*, 27(2), 2-7.
- Godino, J. D., Batanero, C., & Font, V. (2007). The onto-semiotic approach to research in mathematics education. *Zentralblatt für Didaktik der Mathematik*, 39, 127-135.
- Godino, J. D., Batanero, C., & Roa, R. (2005). An onto-semiotic analysis of combinatorial problems and the solving processes by university students. *Educational Studies in Mathematics*, 60 (1), 3-36.
- Stephan, M., Cobb, P., & Gravemeijer, K. (2003). Coordinating social and psychological analyses: learning as participation in mathematical practices. *Journal for Research in Mathematics Education*, 11, 67-102. Reston, VA: NCTM.
- Yackel, E. & Cobb, P. (1996). Socio-mathematical norms, argumentation, and autonomy in mathematics. *Journal for Research in Mathematics Education*, 27, 458-477.



# **GENDER, SOCIO-ECONOMIC STATUS, AND MATHEMATICS PERFORMANCE AMONG HIGH ACHIEVERS**

Helen J. Forgasz

Monash University

*The recent PISA 2006 mathematical literacy results provide evidence that in Western English speaking countries the gender gap in mathematics achievement appears to be widening in favour of males. While participation rates in challenging mathematics courses have consistently been higher for males than females and more males are found among the highest achievers, there had been some closing of the achievement gap as well as some changes in affective outcomes. Socio-economic status has been found to exacerbate gender differences, particularly among lower socio-economic groups. The aim of the present study was to explore the relationships between gender, socio-economic status, and mathematics performance among the highest achievers in the grade 12 Victorian Certificate of Education mathematics subjects.*

## **INTRODUCTION**

Gender issues in mathematics education were first brought to the attention of the research community in the 1970s (e.g., Fennema, 1974). From that time until the 1990s, there was much research attention (Leder, 2001) and funding support for interventions (Leder, Forgasz and Solar, 1996) to address the identified disadvantages faced by girls and women with respect to achievement, participation, and affective outcomes. As the gender gap appeared to be closing with respect to achievement, and with respect to some affective outcomes (e.g., Forgasz, Leder, & Kloosterman, 2004), funding attention moved elsewhere. In Australia and the UK in particular, educational issues with respect to boys surfaced and became a funding focus. There is no dispute that boys' literacy levels are well below girls' (e.g., OECD, 2001) and that attention to this was fully justified. However, there was little evidence to support contentions that boys were disadvantaged with respect to mathematics and science, particularly when participation rates were considered (e.g., Forgasz, 2006; Lamb, 1996). Evidence also persists that males are more likely than females to be the highest mathematics achievers (e.g., Forgasz & Griffith, 2006; Giri, nd; Leder, 2006) and to be identified as the highest achievers (e.g., Hallinan & Sörensen, 1987). Yet, funding to continue work with females in mathematics and science dried up.

It therefore came as no surprise to some that the recent 2006 PISA results for mathematical literacy among Australian, UK, US, Canadian, and New Zealand students reveal statistically significant gender difference favouring males (OECD, 2007). For Australia, there were no statistically significant gender differences in mathematical literacy in the PISA 2000 (OECD, 2001 ) and 2003 data (OECD, 2004). On examination of the PISA data tables (OECD, 2007), it is clear that the gender difference in the Australian 2006 PISA results is mainly due to there being no

difference in males' performance levels compared to 2003 but a decrease in females' overall performance levels. While it is unclear, a lack of consistent government effort and funding support may have contributed to the apparent reversal in earlier trends towards the closing of the gender gap in achievement.

McGaw (2004) noted a strong relationship between social background<sup>1</sup> and mathematical literacy achievement for the PISA 2000 data, with the relationship stronger for Australia, the UK, the US, and Germany than for the Organisation for Economic Co-operation and Development [OECD] as a whole. McGaw (2004) concluded that:

Australia needs to examine carefully the sources of inequity in student performance in its education system to determine where policy intervention might most effectively be made to improve the equity of outcomes without sacrificing policy. This should involve analysis of differences between the public and private sectors, between urban and rural environments and between the States and Territories (McGaw, 2004, p. 24).

In the Australian context (and elsewhere) socio-economic status and ethnicity have been identified as factors interacting with gender in contributing to inequities in learning outcomes (e.g., Lamb, 1996): "In general, the differences between boys and girls become sharper the more socially disadvantaged their parents and the more gender itself operates as a category of cultural manipulation" (Teese, Davies, Charlton and Polesel, 1995, p.109).

## **AIMS OF THE PRESENT STUDY**

One aim of the present study was to continue the monitoring of large scale mathematics assessments for gender differences in the Australian context. Other aims included determining the extent of any gender differences among the highest achievers, as well as the role that socio-economic status might have on any gender differences found.

## **CONTEXT OF THE STUDY**

The relationships between gender, socio-economic status, and mathematics performance were of particular interest in this study. Social background and socio-economic status can be measured in many ways. One crude measure of socio-economic status can be taken as parents' capacity to pay fees for schooling. In Australia, there are three sectors of schooling: i. the government sector in which no or minimal school fees are paid; ii. the Catholic sector for which fees are paid but are not as high, on average, as in iii. the Independent (non-government, non-Catholic) sector for which fees are generally high. In the present study, a student's socio-economic status was considered to be related to the type of school attended: low if attending a government school, medium if attending a Catholic, and high if attending an Independent school. In 2006, across Australia, approximately 67% of students attended government schools, 20% attended Catholic schools, and 13% attended

---

<sup>1</sup> The information on economic and social background - parents' education and occupation, cultural artefacts in the home - permitted the construction of an index of social background that is comparable across countries (McGaw, 2004, p. 11).

Independent schools, with small variations in the various Australian states and territories. This study was set in Victoria and the enrolments in each school sector were taken to be the same as those for the whole country.

In the next section, the participation rates by gender of grade 12 students in Victoria’s final year of schooling (the second year of the Victorian Certificate of Education [VCE]), and the gender break-up of students in the various grade 12 VCE mathematics subjects are described.

**Participation by gender in the VCE and in the VCE mathematics subjects**

At the time of writing this paper, it was unfortunate that the enrolment figures for VCE grade 12 mathematics subjects for 2007 were not yet publicly available. VCE enrolment data and the enrolments for each of the VCE mathematics subjects - Specialist mathematics (the most challenging), Mathematical Methods and Mathematical Methods CAS, and Further Mathematics (the least challenging) - for the years 2003-2006 by gender are summarised in Table 1. The data were obtained from the Victorian Curriculum and Assessment Authority’s [VCAA] website [www.vcaa.vic.edu.au]. Also shown in Table 1 are the mean enrolment numbers over the 4-year period, 2003-2006. For the analyses involved for each of the four mathematics subjects discussed below, it has been assumed that the enrolment patterns for 2007 were similar to those in the preceding four-year period (2003-2006) and the mean enrolment values were used.

Year	VCE enrolments			Specialist Mathematics			Mathematical Methods and CAS <sup>1</sup>			Further Mathematics		
	M	F	All	M	F	All	M	F	All	M	F	All
2003	23482	26794	50276	3961	2411	6372	9978	8439	18417	10694	11424	22118
2004	23243	26498	49741	3831	2462	6293	10026	8367	18383	10866	11893	22759
2005	21945	26413	49273	3526	2128	5654	9335	7893	17228	10605	11831	22426
2006	23100	26924	50024	3247	1991	5238	9185	7592	16777	11106	12510	23616
<b>Mean</b>	<b>22943</b>	<b>26657</b>	<b>49829</b>	<b>3641</b>	<b>2248</b>	<b>5889</b>	<b>9631</b>	<b>8073</b>	<b>17701</b>	<b>10818</b>	<b>11915</b>	<b>22730</b>

<sup>1</sup>Includes enrolments in Mathematical Methods and in Mathematical Methods CAS, an alternative to Mathematical Methods. In the former, students use graphics calculators; in the latter, students use CAS calculators. The curricula are very similar.

Table 1. VCE and VCE mathematics enrolments 2003-2006 by gender

The data in Table 1 indicate that males and females did not participate in equal proportions in the VCE or in any of the VCE mathematics subjects. The mean proportions of male and female students in VCE and in each mathematics subject over the 4-year period, 2003-2006 are summarised in Table 2 below. The data in Table 2 indicate that females make up a higher proportion of VCE students (53.5% on average for 2003-2006) than males. To be proportionally represented in each of the VCE mathematics subjects, females should represent 53.5% of the cohort. As shown in Table 2, however, the proportion of females is less than 53.5% in each VCE mathematics subject, that is, females are under-represented, even though there were more females than males enrolled in Further Mathematics.



	Male	Female
<b>VCE enrolments</b>	<b>46.7%</b>	<b>53.5%</b>
Specialist Mathematics	61.8%	38.2%
Mathematical Methods and CAS	54.4%	45.6%
Further Mathematics	47.6%	52.4%

Table 2. Mean proportions of VCE mathematics enrolments by gender, 2003-2006

Students' performance in VCE subjects are reported in various ways. One, the study score, is a normalised result such that in each subject the maximum score is 50, the mean is around 30 and the standard deviation is about 7; adjustments are made for subjects in which fewer than 1000 students are enrolled. A variation of the study scores is used to produce tertiary entrance scores (currently known as ENTERs) that are used for selection into various university courses (see <http://www.vcaa.vic.edu.au/schooladmin/handbook/2007/PartC07.pdf>).

For each VCE subject, and for study scores of 50 down to 40, the names of students and the schools attended are published in newspapers. The data used in the present study were based on a secondary analysis of the information published in a lift-out section of one of Victoria's daily newspapers, *The Age*, of December 19, 2007.

### RESEARCH APPROACH

For each of the four mathematics subjects offered in the VCE, the data from the newspaper were scanned and entered into an Excel spreadsheet. Scores of 50, 49, 48, 47, and 46 were included. For each subject, scores between 46 and 50 represent 2% or less of the cohort for each subject. Only students' names and the schools they attended were published in the press. Hence, student gender [male [M], female [F], unknown [?]) and school sector (government [G], Catholic [C], independent [I]), had to be identified. Whilst it was fairly straightforward to determine a student's gender for the vast majority of names, some unknown first names were checked on the Internet as well as with people who were likely to know (e.g., Chinese and Vietnamese names). Even so, for a small proportion of students, gender could not be determined as the names were either obscure or unisex (could be used for males or females). The Internet was used to check the sectors to which schools belonged.

### DATA ANALYSES AND RESULTS

For each VCE mathematics subject and for each study score from 50 to 46, frequency counts were determined of student gender (male [M]/female [F]) and school sector (government [G], Catholic [C], Independent [I]).

#### Specialist maths

In 2003-2006, the mean number of students enrolled in Specialist Mathematics was 5889, of whom 62% (3641) were male and 38% (2248) were female (see Table 1). In 2007, there were 65 students ( $\approx 1.1\%$  of cohort) who were awarded study scores between 46 and 50. Of these, 49 students were male (75%) and 15 (23%) were

female; one student's gender could not be determined from the name provided. The results of the analysis by gender and school sector are recorded in Table 3.

Score	All	Gender			School sector		
		M	F	?	Gov	Cath	Ind
50	14	12 (86% <sup>1</sup> )	1 (7%)	1 (7%)	6 (43%)	-	8 (57%)
49	5	5 (100%)	-	-	2 (40%)	-	3 (60%)
48	12	6 (50%)	6 (50%)	-	4 (33%)	1 (8%)	7 (58%)
47	13	11 (85%)	2 (15%)	-	5 (38%)	1 (8%)	7 (54%)
46	21	15 (71%)	6 (29%)	-	4 (19%)	4 (19%)	13 (62%)

<sup>1</sup> Percentage within grouping variable

Table 3. Top-scorers in VCE Specialist Mathematics by score, gender, and school sector

While males represented about 62% of the Specialist Mathematics cohort, it can be seen on Table 3 that, with the exception of those scoring 48 for which only 50% were males, it is clear that the males were over-represented in terms of their cohort representation for each of the other scores, with proportions ranging from 71% (score of 46) to 100% (score of 49).

With respect to school sector, the Independent sector - attended by only 13% of all students, was greatly over-represented among all the high scoring groups, with well over 50% of all students having attended Independent schools. Students from the government sector were under-represented (<67%) as were students from the Catholic sector (<20%), with the exception of the score of 46.

### Mathematical Methods and Mathematical Methods CAS

In 2003-2006, the mean number of students enrolled in Mathematical Methods and Mathematical Methods CAS was 17701, of whom 54% (9631) were male and 46% (8073) were female. In 2007 there were 199 Mathematical Methods and Mathematical Methods CAS students (approx. 1.1% of cohorts) whose scores ranged from 46 to 50. Of these students 133 (67%) were male, 50 were female (25%) and, based on the names provided, it was not possible to identify the gender of 16 students (8%). Study scores of 46 to 50 were analysed and the results are shown on Table 4. As can be seen in Table 4, the proportions of males receiving each of the study scores from 50 to 46 was higher than their representation in the Mathematical Methods and Mathematical Methods CAS cohorts (54%), that is, the females who comprised 46% of the cohort were very much under-represented amongst the highest scorers.

Score	All	Gender			School sector			
		M	F	?	Gov	Cath	Ind	?
50	36	24 (67%) <sup>1</sup>	9 (25%)	3 (8%)	11 (31%)	4 (11%)	21 (58%)	
49	29	24 (83%)	5 (17%)	-	13 (45%)	5 (17%)	11 (38%)	
48	27	18 (67%)	6 (22%)	3 (11%)	14 (52%)	5 (19%)	8 (30%)	
47	41	29 (71%)	11 (27%)	1 (2%)	13 (32%)	4 (10%)	24 (59%)	
46	66	38 (58%)	19 (29%)	9 (14%)	20 (30%)	14 (21%)	30 (45%)	1 (2%)

<sup>1</sup> Percentage within grouping variable

Table 4. Top-scorers in VCE Mathematical Methods and Mathematical Methods CAS by scores, gender, and school sector

With respect to school sector representation, the data in Table 4 reveal that students from the Independent sector were over-represented among the top scorers (>13%) and those from the government sector under-represented (<67%). Students from the Catholic sector were fairly well represented (approx. 20%), particularly for the scores of 49, 48 and 46.

### Further Mathematics

In 2006, there were 22436 students enrolled in Further Methods, of whom 47% (10605) were male and 53% (11831) were female. In 2007 there were 312 Further Mathematics students (approx. 1.4% of cohort) whose scores ranged from 46 to 50. Of these, 187 students were male (60%), 114 were female (37%) and, based on the names provided, it was not possible to identify the gender of 11 students (4%). The results of the analyses of the study scores 50 to 46 are shown on Table 5.

Score	All	Gender			School sector		
		M	F	?	Gov	Cath	Ind
50	60	43 (72%) <sup>1</sup>	13 (22%)	4 (7%)	16 (27%)	12 (20%)	32 (53%)
49	36	19 (53%)	14 (39%)	3 (8%)	15 (42%)	7 (19%)	14 (39%)
48	48	30 (63%)	17 (35%)	1 (2%)	23 (48%)	14 (29%)	11 (23%)
47	60	37 (62%)	22 (37%)	1 (2%)	23 (38%)	11 (18%)	26 (43%)
46	108	58 (54%)	48 (44%)	2 (2%)	36 (33%)	23 (21%)	49 (45%)

<sup>1</sup> Percentage within grouping variable

Table 5. Top-scorers in VCE Further Mathematics by scores, gender, and school sector

As can be seen on Table 5, males were over-represented among the highest scorers (>47%), but were not as dominant as for Specialist Mathematics and Mathematical

Methods and Mathematical Methods CAS. Again, however, students from the Independent sector were clearly over-represented (>13%), those from the government sector under-represented (<67%), and students from the Catholic sector were fairly well represented (approx. 20%) among the highest scorers.

## CONCLUSIONS AND RECOMMENDATIONS

The results of the analyses of the VCE mathematics results for 2007 show a very clear pattern of male dominance among the highest achievers in all the subjects examined. The proportion of males was highest in Specialist Mathematics - the most challenging mathematics subject in which males represented about 62% of the cohort - and less in the other two subjects in which enrolments of males and females were more even. English is often considered a subject in which females dominate. Yet, a cursory glance of the published VCE English results revealed that of the 98 students who scored 50, the female to male ratio was close to 1:1, that is, the relative dominance of males in mathematics was not replicated by females in English.

With respect to socio-economic status, it was also very clear that students attending Independent schools, that is those students whose parents could afford to pay the highest tuition fees (or who were scholarship winners), were clearly outperforming their less affluent peers attending Catholic (lower fee-paying schools) and government schools (no or minimal fees) in all the VCE mathematics subjects.

The study undertaken has again provided evidence of the dual effects of gender and socio-economic status on students' mathematics achievements at the very highest levels, the top 1-2% of all candidates. It will be interesting to know, once the data are published, how the mean performances of males and females in the 2007 VCE mathematics subjects compare. Will the gender differences favouring males that were evident in the PISA 2006 findings be replicated, that is, will there be evidence of a widening gender gap in mathematics performance in these subjects?

The findings on the clear link between socio-economic status and performance needs further exploration. Other factors that might impinge on performance - such as single-sex and co-educational settings, and geographic location, for example - should also be examined. McGaw's (2004) call for the Australian government to identify and address causes for inequities must be heeded. Teacher education programmes should also not ignore the findings reported here. Further research into the mathematics performance of the highest achievers in large scale assessments is clearly needed.

## References

- Fennema, E. (1974). Mathematics learning and the sexes: A review. *Journal for Research in Mathematics Education*, 5(3), 126-139.
- Forgasz, H. J. (2006). *Australian Year 12 Mathematics Enrolments: Patterns and Trends - Past and Present*. International Centre of Excellence for Education in Mathematics. Retrieved Dec. 26, 2007 from: <http://www.ice-em.org.au/pdfs/MathematicsEnrolments.pdf>

- Forgasz, H. J. & Griffith, S. (2006). Computer algebra system calculators: Gender issues and teachers' expectations. *Australian Senior Mathematics Journal*, 20(2), 18-29.
- Forgasz, H. J., Leder, G. C., & Kloosterman, P. (2004). New perspectives on the gender stereotyping of mathematics. *Mathematical Thinking and Learning*, 6(4), 389-420.
- Giri, S. N. (Nd.). *High Achievement in Mathematics and the Girl Child*. Retrieved Dec. 27, 2007 from: <http://www.hbcse.tifr.res.in/episteme1/allabs/giriabs.pdf>.
- Hallinan, M. & Sorensen, A. (1987). Ability grouping and sex differences in mathematics achievement. *Sociology of Education*, 60(2), 63-72.
- Lamb, S. (1996). Gender differences in mathematics participation in Australian schools: Some relationships with social class and school policy. *British Educational Research Journal*, 22(2), 223-240.
- Leder, G. C. (2001). Pathways in mathematics towards equity: A 25 year journey. In M. van den Heuvel-Panhuizen (Ed.), *Proceedings of the 25<sup>th</sup> Annual Conference of the International Group for the Psychology of Mathematics Education* (pp. 1-41- 1-54). Utrecht, The Netherlands: Freudenthal Institute.
- Leder, G. C. (2006). Catering for individual differences: Lessons learnt from the Australian Mathematics Competition. In P. Grootenboer, R. Zevenbergen, & M. Chinnappan (Eds.), *Identities, Cultures and Learning Spaces. Proceedings of the 29th Annual Conference of the Mathematics Education Research Group of Australasia* (Vol. 2, pp. 336-343). Adelaide: MERGA Inc.
- Leder, G. C., Forgasz, H. J., & Solar, C. (1996). Research and intervention programs in mathematics education: A gendered issue. In A. Bishop, K. Clements, C. Keitel, J. Kilpatrick, & C. Laborde (Eds.), *International Handbook of Mathematics Education, Part 2* (pp. 945-985). Dordrecht, Netherlands: Kluwer.
- McGaw, B. (2004). *Australian Mathematics Learning in an International Context*. Keynote address, annual conference of the Mathematics Education Research Group of Australasia. Retrieved Dec. 26, 2007 from: <http://www.merga.net.au/documents/keynote32004.pdf>.
- OECD. (2001). *Knowledge and Skills for Life. First Results from the OECD Programme for International Student Assessment (PISA) 2000*. Paris: OECD. Retrieved Dec. 26, 2007 from: <http://www.oecd.org/dataoecd/44/53/33691596.pdf>.
- OECD. (2004). *Learning for Tomorrow's World. First Results from PISA 2003*. Paris: OECD. Retrieved Dec. 26, 2007 from: <http://www.oecd.org/dataoecd/1/60/34002216.pdf>.
- OECD. (2007). *PISA 2006 Science compEtencies for Tomorrow's World. Volume 1: Analysis*. Paris: OECD. Retrieved Dec. 26, 2007 from: <http://www.oecd.org/dataoecd/30/17/39703267.pdf>
- Teese, R., Davies, M., Charlton, M., & Polesel, J. (1995). *Who Wins at School?* Melbourne: Department of Education Policy and Management, The University of Melbourne.

# CULTURE AND AFFECT: INFLUENCES OF THE TEACHERS' VALUES ON STUDENTS' AFFECT

Cristina Frade<sup>1</sup> and Milene Carneiro Machado

Universidade Federal de Minas Gerais

*This paper reports on an ongoing study about culture and affect in terms of the teachers' mathematical values and the corresponding affective reactions of the students, which they expressed both in relation to their learning and responses to their teacher's practice. The main theoretical frameworks that support the study are based on Bishop's ideas about values and the literature on affect in mathematics education. We present some data to ground our analysis and conjectures. We conclude by raising some research questions for future investigations.*

## INTRODUCTION

During the 1980's we see a gradual change in the teaching of mathematics, in particular in countries with a notably multiethnic population, in relation to socio-cultural issues (e.g. Abreu, Bishop, & Presmeg 2002). Keitel, Damerow, Bishop and Gerdes (1989), for example, show how the social dimension had informed mathematics education research, and clarified the cultural nature of mathematical knowing. Some of that research addressed relationships between mathematics education and its historical-cultural context. Within this perspective the work of Bishop (2002) offers a thoughtful contribution to the discussion of culture and affect, in terms of teachers' values and students' affect. This contribution comes from his observations of apprentices (in general) during their experiences of cultural conflicts, in particular from the exploration of how these experiences influence the students' actions in multiethnic classrooms. The author suggests that teachers' values strongly influence the nature of these experiences and impact students' cognition emotionally and affectively. Like several other researchers, we share the theoretical assumption about the existence of a deep interrelationship between affect in its different manifestations and cognition. According to this assumption, affect is not a thing apart from cognition; it is a part of it (e.g. Zan, Brown, Evans and Hannula 2006).

Our study aims to identify the values of participating teachers' in relation to mathematics, and to research the possible influence of these values on their students' affect. We examine the practice of two secondary mathematics teachers and look for corresponding affective reactions of the students, in terms both of their learning and responses to their teacher's practice. It is not our intention to provide a wide review of the literature related to culture and affect in mathematics education here; instead we explore some academic ideas that we believe are sufficient to enable us to give a sense to, and report on our study. First we present our basic theoretical assumptions,

---

<sup>1</sup> Supported by FAPEMIG and CNPq.

then our methodology and data analysis. We conclude by raising some research questions for future investigations.

### **SOME IDEAS ABOUT CULTURE AND AFFECT**

To talk about culture is to talk about values. Bishop, Fitzsimons, Clarkson and Seah (1999) emphasize that values are not sufficiently discussed in the mathematics education literature, and also that teachers still appear to believe that they do not transmit values in mathematics classrooms. By values Bishop (2002) means *beliefs-in-action*: for him, our values are revealed when we make choices; this is when we express elements of our system of beliefs. Based on Bishop (1988), Seah and Bishop (2000) discuss a categorization for the teachers' values in relation to mathematics, according to three complementary pairs: rationalism and empiricism, control and progress, and openness and mystery. *Rationalism* relates to arguments, reasoning, logical analysis and explanations; it is revealed by the teacher when s/he values the development of students' abilities of argumentation, logical reasoning and mathematical proofs through discussions and debates, and explanations for experimental data. *Empiricism* relates to the processes of objectifying, concretizing and applying ideas in mathematics; it is revealed by the teacher when s/he values the development of students' practical abilities of using mathematical ideas, symbolism, modeling, diagrams and so on, and in collecting experimental data. *Control* refers to the power of mathematical knowledge through its use of rules, facts, procedures, established criteria, and predictions. This value is revealed by the teacher when s/he values the students' abilities to carry out routines, work with mathematical precision, and explore mathematical ideas to predict events. *Progress* relates to the development of mathematical ideas, individual freedom and creativity; it is revealed by the teacher when s/he stimulates students' creativity and alternative explanations. *Openness* refers to the democratization of knowledge by means of proofs, demonstrations and individual explanation; it is revealed by the teacher when s/he stimulates the development of the students' abilities in articulating their own ideas through proofs, verifications, discussions and debates, and in motivating freedom of expression and expression of different points of view. Finally, *mystery* relates to the fascination for scientific mathematical ideas; it is revealed by the teacher when s/he encourages the students' imagination, discussion about the nature of object-knowledge and the meaning of scientific ideas, and the exploration of mathematical puzzles. Whatever the values revealed, says Bishop (2002), their resulting apprehension by the students is a process infused with emotional and affective traces/nuances indicating deeper and more fundamental aspects than can be accounted for from a cognitive perspective. The author has not gone on to produce a detailed discussion of this process, but we can explore its foundations in the literature on affect in mathematics education.

McLeod (1992) identifies three main aspects related to affect to be considered in mathematics education: *beliefs*, *emotions* and *attitudes*; more recently, DeBellis and Goldin (e.g. 2006) added a fourth element: *values*, and proposed a tetrahedral model of affective representation, in which each vertex (beliefs, emotions, attitudes and

values) interacts both with all other vertices and with the individual. Gómez Chacón (2002) argues that beliefs constitute a conceptual schema that filters new information through previously processed information. The function of this schema is to organize our social identity, allowing us to anticipate and make judgments about reality. Later on, Gómez Chacón, Op't Eynde and De Corte (2006) emphasize the crucial role of social contexts in the production of the individual's system of beliefs, looking in particular at the teaching and learning of mathematics. Students' emotional acts and feelings regarding mathematics seem to emerge to a great extent from their mathematical beliefs. Damasio (1996) proposes a distinction between emotion and feelings, and discusses two main types of feelings: feelings of (universal) emotions and background feelings. The former are based on emotions and manifest during an emotional act, giving us a perception of how our body responds to a certain state of emotion like happiness, anger or fear. The latter are more stable and durable in the sense that they are 'accommodated' in our body, making it possible to perceive our body when it is not agitated by manifestations of emotions. According to the Damasio, we subtly account for our background feelings, but are conscious enough of them to be able to talk about their quality. Without background feelings, suggests Damasio, we would not have a representation of the self. Studies on attitudes usually differentiate attitude in relation to mathematics and mathematical attitude (e.g. McLeod 1992, Zan et. al. 2006); the former is associated with affective aspects such as interest, pleasure, curiosity and motivation regarding mathematics; the latter refers to the ways in which the students use their cognitive abilities in mathematical tasks, e.g. flexibility of thought, mental openness, critical spirit, and so on. Given our theoretical assumption about affect and cognition, we prefer not to use this distinction as it suggests that these two kinds of attitudes are somehow independent of each other. We suggest calling the former 'attitudes in relation to mathematics', and the latter 'cognition' or 'mathematical thinking'. In this way, we see attitudes as being modes in which the students express their mathematical beliefs and feelings. Brito and Gonçalez (2001) support such a view. They suggest that attitudes are good indicators of the students' 'mathematical' behavior. However, the authors observe that this behavior is not only set up by what the students would like to do, but it is also constrained by the social norms that regulate what they are allowed to do. As for values, we follow Bishop's notion of beliefs-in-action.

## **CONTEXT AND METHODOLOGY**

The research was carried out in a Brazilian urban secondary school and involved two groups. One was a Year-9 class and consisted of 22 students (10 girls and 12 boys) and their mathematics teacher, Rodrigo; the other was a Year-8 class of 27 students (14 girls and 13 boys) and their mathematics teacher, Fabiana. Rodrigo was an experienced teacher who had been teaching in this school for twenty five years. Fabiana was a novice, and had taught as temporary teacher in this school over a period of two years. Data were collected by: a) a questionnaire for the teacher, b) audio and video recording of a sequence of mathematics lessons; c) audio recording



of interviews with some students; c) audio and written recording of observations in class. Both Rodrigo and Fabiana completed questionnaires before Milene - the second author of this paper - began her observations in their classrooms. The objective of the questionnaire was to identify Rodrigo's and Fabiana's values according to the three pairs of values described by Seah and Bishop (2002), and to contrast these stated values with the values revealed in their practices. Milene started her observations in Rodrigo's class first and then in Fabiana's class. A sequence of ten lessons was audio and video recorded in each class. These observations were focused on Rodrigo's and Fabiana's practice in terms of their mathematical values and the corresponding affective reactions of the students, concerning to both their leaning and their teachers' practices. These affective reactions were identified in terms of the students' mathematical beliefs, background feelings and attitudes, according to the theoretical constructs mentioned earlier. In an attempt to probe for evidence of these in greater depth, some students were also asked for interviews in small groups after the observations in the classes. Throughout all her time in the two classes, Milene interacted with the teachers and the students, participating effectively in classroom activities and addressing the student's doubts. In the next section the sign (...) indicates that parts of an utterance were omitted. Our notes are in brackets.

## ANALYSIS AND DISCUSSION

Rodrigo's Class: Rodrigo does not move too much in the classroom; he stays most of the time sat in his desk. His students are free to sit in small groups; according to him, "*in this way one student helps the other.*" In encouraging this mathematical interaction among students, we understand that he values discussions and debates, which are characteristics of the value *rationalism*. Rodrigo's way of working is like this: he indicates to the students the mathematical topic to be studied in their textbook, asks them to discuss it and do the exercises within the group, and says that the students should go ahead, reading about the next topic and working the corresponding exercises. He always demands that students do routine exercises, which is an indication of the value *control*. He justifies his way of teaching thus: "*in Year-9 there is revision of the topics the students already learned in previous years, so they can walk on their own.*" This utterance indicates that Rodrigo seeks to stimulate the development of the students' autonomy. Also, that mathematical knowledge, for him, is accessible to all as he states that the students are able to learn mathematics by interacting with their peers and with their mathematical text. This could be associated with an idea of democratization of knowledge and, for this reason we say that Rodrigo seems to hold the value *openness*. In a certain lesson a student was unsure about solving an equation related to the calculation of the *lcm*. She asked Milene to help her. Milene assisted her and the girl said that if she had asked to the teacher he would say: "*This [lcm] is a Year-6 topic, as I am in Year-9 I should know!*" The student's statement suggests a belief that she sees Rodrigo as believing that once a mathematical topic is taught it is automatically learnt and is not lost from the mind; put another way, that teaching per se guarantees learning. This seems to

correspond more to an aspect of Rodrigo's values regarding mathematics education than a mathematical value. The didactical resource used by Rodrigo is restricted to the textbook. Some times he uses the blackboard. During an interview one of Rodrigo's students said: "*The mathematics lessons this year are less hard because the methods of our teacher are quite different [probably in relation to previous years]. He thinks that the textbook is there, so we have to study it otherwise it serves for nothing.*" This supports our observation that Rodrigo is not in the habit of proposing extra activities to the students, which could stimulate their fascination by mathematical ideas, a characteristic of the value *mystery*. We also observed that he does not encourage the students to make connections between the mathematical topics under study and daily-life situations. Nor does he discuss any practical applications of these topics. The dialogue between Rodrigo and their students is characterized by questions and answers related to what they are studying in the textbook. For this reason we suggest that he does not stimulate aspects of the value *empiricism*. On the other hand, he encourages individual freedom and alternative explanations in solving problems. In another lesson a student asked for the teacher's help. Rodrigo came to the student, clarified his doubt and said: "*Each problem has lots of possibilities, the choice of method is up to you. Every problem can be solved in several ways, you cannot forget this.*" We suggest that this episode contains evidence of the value *progress*. From both the observations in class and the students' interviews, we have concluded that Rodrigo's practice is strongly marked by a predominance of the values *rationalism*, *control* and *openness*. Moreover, there was no sign, either in the lessons observed or in the students' interviews, of any of the values *mystery* and *empiricism* in his practice. This is interesting if we turn to his responses to the questionnaire where he states that he holds these two values: *mystery* and *empiricism*\*. Our observations of the students' attitudes in class suggest conflicting combination of what the students want to do and the constraints imposed by the norms set up by the teacher, e.g. that they should not need to ask about topics covered in previous years. In fact, although some students seemed to be more interested and motivated to learn than others, all of them made an effort to learn with their mates, read their textbooks with attention, discussed amongst themselves, and did the exercises proposed. They followed all Rodrigo's guidance.

The atmosphere of learning was quite calm and the students seemed to be comfortable in class, although we noted that they were uncomfortable asking Rodrigo to resolve their doubts. We conjecture that the students might be afraid to hear from him that they should know something that was already taught in years before as suggested by the student's statement above. This may also explain why the students called so much on Milene to help them instead of him. Attempting to search for more support for this hypothesis some more students were asked for interviews. When asked by Milene to talk about the mathematics lessons, the students' mathematical beliefs and feelings sounded quite negative. First, a number of students expressed

---

\* The contrast between the teachers' responses to the questionnaire and the values revealed in class is under analysis.

their feelings (of background type we suspect) regarding the way the teacher teaches; they do not feel adapted to the teacher's form of teaching or able to learn with all the autonomy given to them. For example, Isabella said:

The methods of the teacher prejudice many students. He says that everyone has a rhythm. Luana, for example, is on percentages and I am still on the calculus of the geometric solids (...) if everybody was on the same thing, perhaps we would already been on percentages. Each one can have her rhythm, everyone is different, but in a classroom we have to try to walk jointly.

Other students saw this autonomy as suggesting a certain disregard on the teacher's part both for them and for their learning. Carolina said:

The teacher knows nothing about us. He just says: do it, do it. But he doesn't know, we see that he doesn't know. He doesn't come to us to say: is everything OK? Do you have any difficulties?

Consequently, some students have difficulties in mathematics, do not show much motivation to learn, have doubts about the importance of mathematics and no longer like mathematics as before, as suggested by Rafaela:

Last year, we had a more rigorous teacher. We saw that mathematics had value. I think that this year the class doesn't like mathematics and has much difficulty. They confound this difficulty with not liking mathematics.

The sentence "We saw that mathematics had value" well illustrates the situated character of the beliefs, or the important role of the context as Gómez Chácon et. al. (2006) point out. Indeed, Rafaela suggests that she and her mates attributed value to mathematics, but not anymore.

Fabiana's Class: Fabiana sets up lively interaction with her students; she talks to them and moves in the class all the time. Like Rodrigo, her students are free to sit in small groups, but she encourages them to expose and discuss their mathematical arguments and reasoning not only within the group, but to the whole class. In doing so, she also reveals the value *rationalism*. Evidence that she transmits the value *control* can be seen in what she says to her class: "*Now you must do exercises, put your hands up, concentrate (...), do the homework.*" Initially, Fabiana explains the topics of the textbook to the whole class, using the blackboard. The students are silent while she is speaking. Then, she asks them to discuss the exercises amongst themselves and, if they have doubts, she goes to their desks. After finishing the exercises many students put their hands up to show Fabiana that they want to do the exercises on the blackboard. Sometimes she chooses a student to do so, sometimes she accepts volunteers, which is evidence of the value *openness*. Indeed, the atmosphere of learning is marked by the collective participation of the students. Unlike Rodrigo's students, we have not identified in them any conflicting attitudes in relation to mathematics or the way their teacher teaches; they are not afraid to ask for her help. All the students interviewed show positive feelings in relation to these shown here: "*Her lessons are very nice. She teaches and explains very well. I like*

very much her lessons. She jokes with us, smiles and talks a lot. She is a dear friend of the class. She gives us advice. When needed she calls for our attention, when it's time to joke she jokes.” We noted Fabiana’s constant concern to draw the students’ attention to the importance of symbolism for mathematical communication and application of mathematical ideas. In a one lesson, after returning their marked tests to the students, she told them: *“To interpret graphs is very important in daily-life, newspaper and magazines. In our life we are always dealing with this kind of thing, so we need to learn (...) understand, construct [graphs], interpret and calculate.”* We took this as evidence of the value *empiricism*. Both the strategies of teaching and the didactical resources used by Fabiana seem not to be as so fixed as those used by Rodrigo. A girl we interviewed confirmed this: *“She [Fabiana] worked with us the sudoku for us to see how it works. Sometimes she tells us stories of mathematics.”* For this reason we say that Fabiana reveals in her practice aspects of the value *mystery*. Unlike Rodrigo, she explicitly demonstrates to the students her concerns for how they are developing in mathematics, revealing her values of mathematics education. Also, she stresses to them the importance of becoming conscious of the difference between ‘time to study’ and ‘time to enjoy’ as confirmed by the following utterance: *“She [Fabiana] is always alert to the development of the class. She always appears there [in the classroom, out of her class time], giving a ‘sermon’ to us, but at the same time advising us.”* In this case we suggest that she reveals an aspect of values related to education in general. Romulo typifies the reaction of some students regarding these values; this extract from his interview suggests strong feelings of support and care. Example:

She [Fabiana] is caring, tries to talk, for example: when you have difficulties in maths (...) she says: look, you need to study more because your development in this semester wasn’t so good. She always talks, always give us an alert. And I like this because it’s not only a concern with the contents and that’s all! She is also concerned with the students.

We identified the value *progresss* in this statement of Fabiana to her class: *“I’m trying to explain to you my reasoning. There are many others (...) each one can elaborate her (...) what is important is to arrive at the same result (...).”* From our observations in class and the students’ interviews, we have concluded that Fabiana’s practice reveals more balance between the three pairs of mathematical values than Rodrigo’s. We also observed a consonance between the values revealed in her practice and those stated by her in the questionnaire. Fabiana is more explicit to the class than Rodrigo about her educational values, such as her constant concerns with the students’ development and performance. We suggest that this balance and those concerns impact positively upon the students’ beliefs in relation to mathematics as this statement shows: *“I like mathematics, it’s really cool (...) there are lots of things that will be needed in the future, to the profession I will choose, to daily-life, whatever I am going to do.”*

## FINAL COMMENTS

At this stage of our study we hope we have produced sufficient evidence that teachers’ values strongly impact upon students’ mathematical beliefs, feelings and attitudes. We suggest that further research focus on the relationship between this

impact and students' cognition. We think that an exploration of the students' self-esteem as it relates to these affective components might be a good first step.

### Endnote

We are grateful to our research assistant Guilherme Lopes from the PROVOC program for his dedicated work on the organization of our data and Peter Winbourne who kindly corrected and advised on the English version.

### References

- Abreu, G., Bishop, A., & Presmeg, N (Eds.) (2002). *Transitions between Contexts of Mathematical Practices*. Dordrecht, Holland: Kluwer A. Publishers.
- Bishop, A. J. (1988). *Mathematical Enculturation: A Cultural Perspective on Mathematics Education*. Dordrecht: Kluwer.
- Bishop, A. J. (2002). Mathematical Acculturation, cultural conflicts, and transition. In G. de Abreu, A. J. Bishop, & N. C. Presmeg (Eds.), *Transitions between Contexts of Mathematical Practices* (pp.193-212). Dordrecht, Holland: Kluwer A. Publishers.
- Bishop, A. J., Fitzsimons, G.E., Seah, W.T., & Clarkson, P. C. (1999). Values in Mathematics Education: Making Values Teaching Explicit in the Mathematics Classroom, Paper presented at the *Australian Association for Research in Education*, Melbourne, 1999.
- Brito, M.R.F. & Gonçalves, M.H.C.C. (2001). A aprendizagem de atitudes positivas em relação à matemática. In *Psicologia da Educação Matemática - Teoria e Pesquisa*. Campinas: Insular.
- Damasio, A. (1996). *Descartes' Error: Emotion, Reason and the Human Brain*. Papermac, Basingstoke.
- DeBellis, V.A. & Goldin, G.A. (2006). Affect and meta-affect in mathematical problem solving: a representational perspective. *Educational Studies in Mathematics*, 63, 131-147.
- Gómez Chacón, I. M. (2002). Cuestiones afectivas en la enseñanza de las matemáticas: una perspectiva para el profesor. In L. C. Contreras & L. J. Blanco (Eds.), *Aportaciones a la Formación Inicial de Maestros en el Área de Matemáticas: Una Mirada a la Práctica Docente*. Universidad de Extremadura. Cáceres.
- Gómez Chacón, I.M., Op't Eynde, P., & De Corte, E. (2006). Creencias de los estudiantes de matemáticas. La influencia del contexto de clase. *Enseñanza de las Ciencias*, 24(3),309-324.
- Keitel, C., Damerow, P., Bishop, A., & Gerdes, P. (1989). Mathematics, education and society (*Science and Technology Education Document Series No. 35*) UNESCO, Paris, 1989.
- McLeod, D. B. (1992) Research on affect in Mathematics education: a reconceptualization. *Handbook of Research on Mathematics Teaching and Learning*. New York: Macmillan.
- Seah, W.T. & Bishop, A. (2000). Values in mathematics textbooks: a view through two Australasian regions. Paper presented at the *81st Annual Meeting of the American Educational Research Association*. New Orleans, 2000.
- Zan, R.; Brown, L.; Evans, J., & Hannula, M.S. (Eds.) (2006). Special Issue on Affect in Mathematics Education. *Educational Studies in Mathematics*.

# MATHEMATICAL BELIEFS AND BEHAVIORS OF HIGH SCHOOL STUDENTS: INSIGHTS FROM A CASE STUDY

John Francisco

University of Massachusetts

*This paper examines the mathematical beliefs of a high school student and his behavior in a mathematical task. The student was a participant in an NSF-funded longitudinal study on the development of mathematical ideas, forms of reasoning and proof. The beliefs were collected in an interview with the student on his experiences on the longitudinal study in the 12<sup>th</sup> year of the longitudinal study. The mathematical behavior resulted from observations of the student in a probability task. The results challenge findings regarding epistemological beliefs and mathematical behavior of high school students and highlight the advantages of a research framework that involves a simultaneous analysis of students' views and behavior in mathematics.*

## **THEORETICAL FRAMEWORK**

The field of personal epistemological beliefs describes individuals' views or beliefs about [mathematical] knowledge and knowing. It is a thriving domain of research, as suggested by recently published reviews (Pintrich & Hofer, B. K., 1997; Hofer & Pintrich, 2002). However, in addition to providing a comprehensive account of the advances made in the field since the pioneering work of Perry (1990), the reviews also point out a number of challenges that remain to be addressed. In particular, Pintrich (2002) asks whether beliefs should be inferred from or read into individuals' actions, suggesting the need for more studies that examine the relation between individuals' views and their actions or behaviors. Not even the expansion of the epistemological construct to include individuals' views on learning (Schommer, 2002) has resulted in more such studies. Similarly, the reviews also remark that much of the research has taken place at college level and very few studies exist involving students below college and even fewer below high school. As a result, students below high school have been assigned the same naive epistemological views identified in freshmen college students.

The dangers of failing to examine the relation between students' views about mathematics and their mathematical behavior have been stated in the few studies that have been conducted so far in the area. They are all related to observed "behavioral inconsistencies" in students, whereby they can give "give clear evidence of knowing certain mathematics, but then proceed to act [behave] as if they are completely ignorant of it", such as the case of high school students' mathematical beliefs who reportedly expressed the view that mathematics was about learning how to think, but would not try any further to accomplish a task if it took on average more than 20 minutes (Schoenfeld, 1989). The direct implication is that failure to examine beliefs or behavior may not provide a full account of the intellectual growth of an individual.

In line with this idea, a new framework for understanding problem-solving performances sustains that students' performance in solving problems cannot be fully understood without taking into account mathematical beliefs (Schoenfeld, 1985). Similarly, studies that examine only mathematical beliefs run the risk of regarding students as sophisticated, when in reality they may have just picked up the "rhetoric" and not be "substance" of mathematical structures (Schoenfeld, 1989, p. 340). Therefore, more work is needed to understand the relationship between individuals' views about mathematics and their behavior in problem-solving situations. This study examines the mathematical views of a student and his mathematical behavior in mathematical problem-solving situations, which were designed to challenge his views. The results challenge the widespread belief in the field of epistemological beliefs that students below high school students hold naive epistemological views. Even more, the analysis of the student's behavior shows that, not only did the student hold non-naive views about mathematics, but he also exhibited behavior that was consistent with his views during eth problem solving situations. The study characterizes the students' views and behavior and examines the particular conditions that may have contributed to their development over time.

## **METHODS**

This study reports on the experiences of Mike, who was a participant in a longitudinal study in which students regularly engaged in after-school mathematical investigations as a context for the study of the development of mathematical ideas, reasoning and proof in conditions where they were encouraged to work collaboratively, explore patterns, make conjectures, test hypotheses, reflect on extensions and applications of learned concepts, explain and justify their reasoning. Mike participated consistently in the study since its inception in first grade. His mathematical views were inferred from 45 minute-interview on his perception of his experiences in the longitudinal study. This was followed by observations of his mathematical behavior in 1-hour problem-solving session on the following World Series Problem (WSP) probability task in which in he worked with a colleague:

In a World Series two teams play each other in at least four and at most seven games. The first team to win four games is the winner of the World Series. Assuming that the teams are equally matched, what is the probability that the World Series will be won: a) in four games b) in five games c) in six games d) in seven games?

Both the interview and the problem solving session were videotaped. The interview followed a phenomenological approach, seeking to infer Mike's views on learning from the meanings that he assigned to his experiences in the longitudinal study (Creswell, 1988). The interview started with a question: "What are your early memories of longitudinal study?" which allowed Mike to decide on what was personally relevant to him in his mathematical experiences and how he intended want to articulate it. Over time, more structure was imposed on the interview, as clarifications and/or elaborations were sought and the interview was directed to target particular issues that emerged during the interview.

By the time this study was conducted, Mike was in high school and the longitudinal study was in its 12<sup>th</sup> year. It was the third time in which Mike had worked on the World Series Problem. In the first session, Mike worked with four other students. Using probability as ratio, the group came up with the probabilities  $P(4)=2/16$ ,  $P(5)=8/32$ ,  $P(6)=20/64$  and  $P(7)=40/128$  in a session that lasted more than one hour. The students used brute force to list all possible series winning game combinations for the numerator of the ratio and computed the denominators as a power of 2. The solution is referred to in this paper as the “*original*” solution. In the second session, the Mike and the same four students were asked the students to make sense of proposed “solution” by another group of students with the same numerators, but with a common denominator, 70, computed as the sum of all series winning game combinations:  $P(4)=2/70$ ,  $P(5)=8/70$ ,  $P(6)=20/70$  and  $P(7)=40/70$ . The solution is known in this paper as the *alternative* “solution.” The goal was to test the strength of the students’ thinking. This created disequilibrium in Mike who was no longer sure which solution was correct. The third session was designed to provide Mike with an opportunity to reach closure.

The analysis of the data followed procedures used in phenomenological qualitative data analysis methods (Moustakas, 1994 and Giorgi, 1985), and incorporated analytical techniques suitable for the analysis of video recordings (Francisco & Maher, 2003; Erickson, 1992). Six steps were used: (1) Viewing the entire interview or problem solving session, (2) Partitioning the Interview/session major into episodes, (3) Determining significant statements/behavior, and (4) Clustering significant statements/behaviors into themes, (5) Describing Mike’s view and major behaviors, and (6) comparing the views and behaviors. The themes emerged from the data as result of the application of constant comparison method. The analysis of the interview preceded the analysis of eth problem solving session.

## **MIKE’S VIEWS ON MATHEMATICAL LEARNING**

Mike referred to his mathematical experiences in the longitudinal study as “Rutgers math” and described them as “kids running the class. This was an idea that explained in a variety of ways, as he often compared his experiences in the longitudinal study and high school.

### **Meaning and durability**

Mike suggested that in the longitudinal study, researchers did not tell or show students what to do. Instead, they allowed the students to come up with the ideas or “say it” themselves. Mike argued that it enhanced mathematical understanding and the ability to build durable ideas:

If you tell a kid something, they might understand; they might not; but if a kid says it himself, then obviously, he understands it. You get to understand things a lot better if you’re running the class. Obviously, the teacher understands it, but who knows if the kids do? They could just be copying it down. A week later, they’ll never remember what they did.



## Discovery learning

The previous statement suggests that Mike favoured a discovery approach to learning over knowledge being passed to students by experts. This was an idea that was implicit in Mike's statements in a number of ways. First, he argued that Rutgers researchers "let us [students] do our thing," whereas the teachers in school talked and students simply to "write things down." He claimed that students did not have as much input in their learning in school as they did in the "Rutgers math" program:

The Rutgers math felt different from the math we did in class because, when we would do the Rutgers sessions, it was like the kids were running the class. You [researchers] would ask us something and then step down and let us do our thing. When I was in [inaudible], the teacher would just like mainly talk and you'd write things down. Students don't have that much input in what they were learning.

Second, when asked how he could change mathematics teaching in schools, Mike immediately said that he would not use textbooks with his students. He explained that he was not so much against using textbooks as much as he was against *how* they were being used in school. He claimed that he was against giving students "pages out of the [same] textbook" because "that's not going to teach them anything."

First thing, like I'd probably, like, would not even give my kids books. I would, like everyday, I'd give them something new, or like even, like what we would do is just talk about this, like, geometry-related problems, and stuff like that. I wouldn't just give them pages out of a book. That's not going to teach them anything.

Mike was also against what he described as students "copying down" from textbooks, or using them as the main sources for learning:

I'm not saying eliminate the books, but like eliminate, like, using books during class, like copying down and all of this. But you can use the books, take some of the problems from the books, but not use them as your main source. Because, it's like the books that teach you, not the teacher.

Finally, Mike also explicitly said that students' discovery of ideas through mathematical explorations and collaborative work over time was "a better way of learning" mathematics than teachers telling them about the ideas. Again, Mike argued that it would enhance student understanding of mathematics:

Well, kids can learn new things, because if they discover them themselves, and not if somebody tells them, I think that's a better way of learning. Like if you, if in the class, like Mr. Pentozzi, he gives us some information, but basically, he lets us discover the things that a normal teacher would just tell us. Like we were learning about E, and he told me that when he was in school, the teacher told them, "E is this, 2.7, whatever." The teacher told him what it is. In our class, all we did was just explore E. We took days at a time, and I have a good understanding of it. Like, if you were going to, I guess, a normal class, you'd have to be; like, only selected kids might understand it. But in a class where everybody's working together, everybody's a part of the teaching, and everybody, or at least the majority of kids will understand it.

## Arguing about ideas

Mike elaborated on his idea of collaborative work. The students in the longitudinal study often referred to it as “arguing” with each other. Asked to comment on the issue, Mike related it with probability, which he called an “Iffy” subject because often he was not sure whether to believe in a mathematical result or his intuition.

The reason we argued about math, because math is like, when we do about probability, probability is an iffy subject. Like, sometimes, I mean the math says it’s right, but do you believe it’s right, and sometimes that influences your decision. That’s probably why we argue I remember the problem with the World Series Problem, we had two different answers. I still don’t know which one is correct.

Mike’s comments suggest that arguing was a mechanism to seek certainty or proof and arguments were simply more common in probability tasks than in other problems.

## Learning as thinking

Asked whether he thought that what he learned in the longitudinal study was applicable in other disciplines and life in general, Mike thought that the type of thinking he learned could be used in other subjects and real life:

I guess I use the type of thinking in, like other subjects in school; I don't know how you can apply it to life. Maybe I have and I just don't know. Because it's hard to recognize what style of thinking you're thinking of. I can't compare it with someone else's because I don't know what they're thinking. So, I think, yeah, I probably do use it in life, and other subjects in school.

In summary, Mike views mathematics as a sense making, discovery, and discursive activity whereby students work together to come up with and validate ideas.

## MIKE’S BEHAVIOR: FOUR CRITICAL EPISODES

This section describes selected moments in the World Series Problem from which inferences will be made about the relation between his views and his behavior.

### Critical Episode 1: Flexibility

Mike and Robert initially favoured different approaches for solving the problem. Robert wanted to proceed by *brute force* and list all possible series-winning game combinations. Mike had taken part in the previous session and had seen how difficult it had been to use Robert’s strategy. He preferred a more abstract approach involving a search for combinatorial formula. He warned Robert about his strategy by saying, “There’s a lot of [*sic* too many] chances of how the games could go. You know?” However, he did not try to prevent him from pursuing it. Instead, he urged Robert to try to find a pattern in the listings by saying, “Try, try to find, like, a - you know, like - there’s a reason for that twenty, or something - just ‘cause there is.” It was only when Robert eventually said, “Oh, this is too hard,” that Mike replied, “Told, told you it was a pain,” and invited him to work with him on his strategy:

Watch this [takes new sheet of paper]. All right. I was thinking of it in terms of choosing, all right? So, this one is like, um, five choose four and the next one is six choose four. All right? So, the answer to five choose four is, um, it's five choose-

Mike's display of flexibility proved critical. He and Robert used Robert's partial list of game combinations to find a pattern for the combinatorial formula. Also, the timing of Mike's invitation meant that Robert was more willing to accept it than he was in the beginning before he had even tried his strategy.

### **Critical Episode 2: Reconsidering Ideas**

The first "solution" that the students arrived at was the *alternative* solution. Mike attempted twice to convince the researcher of its validity. In both cases, the researcher sent them back to the drawing board with further questions to think about. The first time, they were asked to consider whether the 70 outcomes were equally likely since, as the researcher put it, "numerically, you're doing that." The second time, the students tried to use the fact that the probabilities of the series ending in 6 and 7 games were the same in the *original solution* to reject it on grounds that it was counterintuitive. The researcher asked them to consider the plausibility of the finding before using it as a basis to reject it. Eventually, the researchers' questions seemed to lead Mike to reconsider his ideas and shift his attention from the alternative solution to the original solution:

[Talking to Robert] Well, I think some - *something's up with that, because she wouldn't ask that*. Man, she had to go and mess us up like that. So you have - you've got sixteen different possibilities that happen in four games, right? Correct?

Also, when examining why the probabilities might be the same, Robert insisted that he believed in the alternative solution, but Mike wanted to examine the question because "there's got to be a reason."

*No, let's just think about why, why twenty and forty*. Why they exactly doubled, you know? And the other ones weren't. And, I mean, there's got to be a reason because -. Let's go back to where we were before. Where's all my stuff? I should have written more stuff down. Um - let's say you figure in six games. You have how many possibilities for six games? Twenty of them. The last game could either be a win or a loss for both. So figure - all right, watch. You've got three - when you get to the sixth game, if you don't win anything, there has to be three on one side, three on the other, right?

Mike's willingness to suspend his belief in the alternative solution, and examine the original solution for its own potential merits eventually paid off as he eventually allowed him to explain the finding and reach closure on the problem.

### **Critical Episode 3: Peer versus expert collaboration**

Initially, Mike used Robert as springboard. However, over time, Mike increasingly sought exchanges with the researcher, as he started to ask questions to the researchers, as opposed to just defending his ideas, despite the researchers' insistence that he talk to Robert. The first instance occurred as he tried to defend the alternative solution on grounds that in the original solution  $P(6)$  and  $P(7)$  were equal. Mike

asked the researcher, “Can I ask you a question?” Although the researchers insisted, “Talk to, talk to Robert.” Mike still asked the question, “Do you think it’s, um, harder to win it in six? Like, do you think it’s, it’s easier to have the game won in seven or six games, or you [inaudible]- “ The researcher invited the students to think further about the question: “Well, I think you have to think about -“

In another instance, when he finally came up with an argument for why probabilities were the same, Mike wanted to test his ideas with researcher, despite Robert protests:

I’m trying to think, too. I’m not seeing anything. *Hey, get her in here.* I want to tell her about how - it doubles. I want to tell her that and see if she says anything. Maybe she’ll give us an idea.

Robert protested that, “Come and leave, like, every five minutes?” but Mike insisted that they called the researcher.

#### **Critical Episode 4: Sense making**

Despite the consultations with Robert and the researchers, sense making was the ultimate criteria by which he made his decisions. After he explained why  $P(6)$  was equal to  $P(7)$ , Mike was asked by the researcher which solution he believed in. He promptly said, “Well, I guess, you know, I kind of believed this one more because then *there actually was an explanation* why the numbers are the same.”

#### **CONCLUSIONS**

The interview provides more insights on Mike’s views on issues regarding learning and teaching than they do on the nature of knowledge and knowing. Opportunities for students to try and come up with ideas as opposed to teachers’ lectures, non-reliance on textbooks, students’ discussions as a way of proving claims, discovery of ideas, all refer to processes involved in knowledge acquisition than they refer to the nature and justification of knowledge, making it difficult to make direct inferences on whether Mike holds a simplistic, dualistic and absolute as opposed to complex, relative and contextual view of knowledge. However, Mike’s emphasis on discovery learning and mathematical discussions as a means for achieving certainty suggests recognition of the centrality of learners’ [mathematical activity], as the source of new knowledge and its justification, respectively. Mike’s beliefs are also consistent with the underlying ideas of the on-going reform movement in mathematics education in USA in emphasizing the importance of meaning, convincing arguments, and discovery of ideas, and discursive activity as opposed to lectures or use of textbook-based instruction. Also, behaviors such as flexibility, ability to reconsider his ideas, validity based on sense making make it difficult to associate Mike with simplistic and dualistic right or wrong view of knowledge. For this reason, it is difficult to associate Mike with naive epistemological views even though he was still in high school student.

Mike’s views were reflected in his behavior in the World Series problem. His refusal to accept the original solution until he was able to explain why the probabilities of the

series ending in 6 or 7 games were the same is consistent with his emphasis on learning as sense making activity. Mike also worked collaboratively and discursively not only with Robert but also the researcher, showed signs of ability to accommodate other people's ideas, and also reconsider his own ideas are also consistent with a view of mathematics as a sense making, collaborative, discursive activity. His search for exchanges with the researcher was more about finding someone challenging to think *with* than it was about being told the answer. For this reason, Mike's behavior was consistent with his views. Also, it is particularly significant that some of the behaviors provide compelling readings of Mike's views. In summary, this study shows that, given the right opportunity, students below high school can hold epistemological view that are not naïve and also exhibit behavior that are consistent with the views. These include, learning environments which emphasize understanding, make it safe for students to come up with, test, and validate their ideas either individually or a collectively, as opposed to merely listening to experts.

## References

- Creswell, J. W. (1998). *Qualitative inquiry and research design: Choosing among five tradition*: Thousand Oaks, CA: Sage.
- Erikson, F. (1992). The interface between ethnography and microanalysis. In M. D. LeCompte, W. L. Millroy, & J. Preissle (Eds.), *The Handbook of Qualitative Research in Education* (pp. 201-225): San Diego: Academic Press.
- Giorgi, A. (Ed.). (1985). *Phenomenology and psychological research*: Pittsburgh, PA: Duquesne University Press.
- Moustakas, C. E. (1994). *Phenomenological Research Methods*: Sage Publications.
- Perry, W. G. (1970). *Forms of Intellectual and Ethical Development in the College Years: A scheme*. New York: Holt, Rinehart and Winston.
- Pintrich, P. R. & Hofer, B. K. (1997). The development of epistemological theories: Beliefs about knowledge and knowing and their relation to learning. *Review of Educational Research*, 67(1), 88-140.
- Pintrich, P. R. (2002). Future challenges and directions for theory and research on personal epistemology. In B. K. Hofer & P. R. Pintrich (Eds.), *Personal Epistemology: The Psychology of Beliefs about Knowledge and Knowing*.
- Powell, A. B., Francisco, J. M., & Maher, C. A. (2003). An evolving analytical model for understanding the development of mathematical thinking using videotape data. *The Journal of Mathematical Behavior*, 22(4), 405-435.
- Schoenfeld, A. H. (1989). Explorations of students' mathematical beliefs and behavior. *Journal of Research in Mathematics Education*, 20(4), 338-355.
- Schommer, M. (2002). An evolving theoretical framework for an epistemological belief system. In B. K. Hofer & P. R. Pintrich (Eds.), *Personal Epistemology: The Psychology of Beliefs about Knowledge and Knowing*. Mahwah, NJ. Lawrence Erlbaum Associates.

# **AFFORDANCES OF INQUIRY: THE CASE OF ONE TEACHER**

Anne Berit Fuglestad and Simon Goodchild

University of Agder

*Inquiry ‘as a tool’ and ‘as a way of being’ is presented as a goal in a mathematics teaching developmental research project. The project is described and methodology outlined. A case of one teacher’s attempt to introduce open problem task is explored to find evidence for the teacher’s critical reflection on his own practice and the affordances of inquiry that pertain. The teacher’s model of teaching and learning, his prior experience and teaching goals are revealed to be key conditions in the case.*

## **INTRODUCTION**

We report from a sequence of events that constitute a ‘case’ within a large mathematics teaching development project. The project is about the development of ‘communities of inquiry’ comprising pupils, mathematics teachers and didacticians who collaborate to improve the teaching and learning of mathematics in school and research the developmental processes. All participants are researchers, thus we refer to the university researchers as ‘didacticians’. ‘Inquiry’ is a fundamental concept that runs through all aspects of the project: learning mathematics, teaching mathematics, development and research. We examine the ‘case’ and ask: what is the evidence of inquiry and the circumstances of inquiry? The full analysis of the case includes inquiry within and between all layers of the project, pupils, teachers and didacticians; in this report we focus upon the actions of one teacher. We begin by explaining the way inquiry is conceptualised within the project. There follows a description of the project and methodology. The particular case is then outlined and discussed.

## **INQUIRY AS A TOOL / INQUIRY AS A WAY OF BEING**

In her plenary lecture at PME 2004 Jaworski explains the constructs of ‘inquiry as a tool’ and ‘inquiry as a way of being’. She carefully argues: ‘inquiry as a way of being is fruitful for development ... inquiry as a tool is valuable to induce inquiry as a way of being’ (Jaworski, 2004, p. 27). In our teaching development projects one of our concerns has been to stimulate all participants within the project to inquire into, i.e. to question critically and reflectively, their own activity. We want pupils in classrooms to ask questions about the mathematics in which they are engaged. The point here is, that the pupil does not first ask the teacher - for a quick answer, rather the pupil develops a questioning attitude that leads to sense making and ‘principled knowledge’ (Edwards & Mercer, 1987, p. 97). As Brousseau remarks: ‘solving the problem is only part of the work; finding good questions is just as important as finding their solutions.’ (Brousseau, 1997, p. 22). Brousseau’s comment relates specifically to the learning of mathematics but we believe it can be applied to all layers of our developmental activity.

For the teacher, the aim is to develop an attitude of critical reflection towards their own practice; this entails questioning their own actions and outcomes. Teachers also ask pupils questions; in this respect inquiry is being used as a tool to stimulate learning, and the aim is to pose pupils questions that induce them to be reflective questioners of the mathematics in which they engage. Didacticians form a third layer of research and development. For didacticians ‘inquiry as a way of being’ entails questioning reflectively the development and research processes in which we are engaged. Didacticians also use questions as tools, to stimulate teachers’ inquiry into their own practice, and to stimulate pupils’ inquiry into the mathematics.

## **MACRO-CONTEXT OF THE RESEARCH**

The ‘case’ we report is part of a mathematics teaching development project based in the southern part of Norway. It is a ‘binary’ project with two separately funded parts. In one part, called ‘Teaching Better Mathematics’ (TBM) university researchers are funded by The Research Council of Norway (project no. 176442), in the other part, called ‘Learning Better Mathematics’ (LBM) didacticians, teachers and schools are funded by local development funds (Sørlandets kompetansefond). The combined aim of TBM/LBM is to develop knowledge and practice in the teaching and learning of mathematics, so that pupils in schools have better learning experiences and achieve better conceptual understandings of mathematics. Pupils should demonstrate fluency with mathematics based on principled knowledge and deep understandings.

At a macro level the project seeks to address a number of embracing research questions such as: How do we (didacticians) address teachers’ own mathematical needs? How do the wider demands of teaching impinge on the possibilities for engagement in inquiry? If a credible developmental model, suitably resourced, is applied to enable teachers and didacticians to develop as critically reflective practitioners, what factors have to be recognized and addressed? This report relates to research questions that emerge at a micro-level within the project although it is intended that the work reported will contribute to these wider macro-questions.

## **METHODOLOGY**

The project is set within a developmental research paradigm in which the research and development interact in cyclical processes (Gravemeijer, 1994). Theory, generated through research, guides the developmental activity, which in turn informs the theory. Didacticians and teachers collaborate in co-learning partnerships (Wagner, 1997) in which the research and development activities are shared, and together we seek to learn and create new knowledge. Teachers and didacticians have different responsibilities, in particular, teachers for their classes, and didacticians an obligation to make research public (Stenhouse, 1979/1983). We seek to establish a community of inquiry (Jaworski and Goodchild, 2006) comprising teachers and didacticians, in which ‘inquiry’ is taken as a fundamental principle and approach for developing teaching and learning mathematics. How this works in practice will be made clear in the account of the case study that follows. In the next two paragraphs, for the sake of

clarity, we outline the development and research methods separately, however we want to stress from the outset that they are, in practice, inseparable.

### **Development methods**

The key developmental methods are workshops held at the university or one of the project schools. The fine detail of the workshops is planned by didacticians but representatives of school authorities and school teams agree the topics to be included. The workshops comprise plenary presentations by didacticians and reports of activity in school by teachers, and small group sessions in which both mathematics problems and didactical issues are taken as the foci for discussion. One aim of the workshops is to stimulate design activity by teachers. It is intended that teachers will use the mathematical tasks presented, and perhaps partly worked on in a workshop. Either individually, or it is hoped in school teams, teachers design lessons based on these tasks, implement and evaluate the lessons following an inquiry cycle of plan-implement-observe-reflect-feedback into new plans. Teachers may invite didacticians to observe and make video recordings of lessons. In subsequent discussions between teachers and didacticians, or in reporting back to workshops, the video recordings may be used to illustrate and stimulate reflection. Thus the inquiry cycle is also evident at a more global level in the planning and implementation of the workshops.

### **Research methods**

The main approach taken in data collection is to record, either video or audio, all activities that take place within the project. When didacticians visit schools, teacher team meetings and classroom activity are recorded. As teachers are realising the potential of recordings as a developmental tool so more such recording is taking place when didacticians are not present. In this respect the major part of the data collected is ‘naturally occurring’ or ‘naturalistic’ (Potter, 2002), in other words: events are not staged with the specific purpose of generating data. Some additional data is collected, in the form of interviews with teachers. It might be argued that such data collection activity changes the nature of the research to be ‘data extraction’ (Wagner, 1997), however, the interviews serve both development and research functions and both teachers (interviewed) and didacticians (interviewers) learn from the event. The huge amount of data produced is stored electronically, carefully labelled, filed and indexed, so that it is available for the whole team of didacticians (9 at present with plans for growth) engaged in the project.

### **THE CASE OF RIKARD’S DEVELOPMENT OF INQUIRY APPROACH**

We now focus on one case study within the project. The ‘case’ relates to the way one teacher, Rikard, responded to ideas presented in a workshop. Rikard is an experienced teacher who has a half year of mathematics after his teacher education course. Our account is based upon recordings of events in which the teacher took an active part: in small groups in workshops and in his own class. The naturally occurring data has been augmented by an interview with the teacher, conducted for



this case study. The case developed over some weeks in the autumn where Rikard participated in two workshops in the TBM project, engaged with colleagues in group discussion and followed up by developing ideas from the workshop in his teaching. A didactician, Aud, followed up his invitation to observe his class and gave informal input which he also followed up in the next lessons with his class.

One of the challenges faced by didacticans within the project has been how to communicate what is meant by ‘inquiry’ tasks and approaches to mathematics. Also didacticans have been concerned to demonstrate how tasks, which teachers have used routinely within their regular interpretation of the curriculum, can be opened up into ‘inquiry’ tasks. The use of ‘open problems’ in mathematics is well documented in the literature, and indeed for many years it has been a well represented research domain within the international PME community. Thus we do not believe it is necessary in this paper to articulate a justification for introducing open-ended problems to the TBM/LBM project community.

### **Stimulating inquiry through a workshop**

In a plenary session the TBM workshop on 19 October the theme was “How can we prepare tasks characterised by an inquiry approach?” Various ways of opening up tasks were presented, inspired by Prestage and Perks’ book (2001). This included also removing information to make tasks more open, and in some cases led to what are sometimes referred to as ‘Fermi problems’. These are ‘plausible estimation’ tasks, which consist of one or two easily-stated questions which at first glance seem impossible to answer without reference material, but which can be reasonably estimated by following a series of simple steps that use only common sense and numbers that are generally known or amenable to estimation (Swan and Ridgway, n.d.). The tasks are named after the Nobel laureate Enrico Fermi who used these types of problems in his teaching. One oft quoted example is ‘how many piano tuners are there in Chicago’. A ‘Fermi’ type problem was shown as an example of a very open question. Didacticans had some experience of using these with learners at a variety of ages to give insight into thinking and understanding.

The plenary session was followed by group work on the same theme. Rikard teaches a grade 8 class, pupils are 13-14 years old. In the group session he joined other teachers (from his own and other schools) who work with pupils at grades 8 and 9. The group discussed a task from one of their textbooks that concerned sharing a box of 48 clementines between 8 pupils in the class. They discussed various ways of reformulating the task and ended up with a task without any numbers in it, but with the request to have a fair sharing of clementines, that is they transformed it into a ‘Fermi’ problem. Victor, who teaches in the same school as Rikard, mentioned that the task with use of a spreadsheet could lead to algebraic thinking.

Nearly two weeks later, Aud received a copy of an e-mail sent by Rikard to the other members of his workshop group telling that he would try out these tasks in his class the following Monday and inviting the others to observe. He also arranged with a

student-teacher to film the lessons. Aud had visited Rikard's class several times in a previous project and she welcomed the invitation to act as a participant observer.

### **Implementing inquiry approaches in the classroom**

The lesson started with Rikard introducing six tasks which were printed and handed out to pupils. He read each of them and emphasised that the work was not just to give an answer but also that the pupils must be prepared to explain their thinking which led to their solution. The pupils worked in small groups of 2 - 3, in partnerships suggested by Rikard. Groups could use a computer if they wanted. The groups could choose which of the tasks to work on. Rikard advised groups to choose a task they thought they would be able to solve and then to decide the quantities it was necessary to estimate, numbers should be realistic and chosen so the task did not become too difficult. This class had not tried similar tasks before, Rikard met the class first about ten weeks earlier. The pupils at first showed some insecurity and wondering about how to work on such tasks. For example one group that worked on the clementines task, at first suggested just saying 27 pupils then we could have 2 or 3 clementines for each in the box with 60 clementines. To make it fit, their teachers could have some. The pupils did not consider the size of the box. Both Aud and Rikard observed in turn, after a few minutes Rikard asked questions about the size of the box: "Have you estimated how many clementines are in the box?" This stimulated the pupils to discuss more the size of the box, if it is a big or small box. In the last part of the lesson the pupils presented their solutions and explained how they worked on the tasks. Rikard responded briefly and prompted further comments from the whole class. If they had anything written on their computer it was loaded into the teacher's computer and displayed a big screen.

### **Reflecting on the implementation**

In an informal chat with Aud just after the lesson Rikard reflected: "How can I take this further?" He suggested more variation in numbers and finding connections between them. Aud responded by suggesting he could think about taking this to introduce some early algebraic thinking, including variables and functions. Rikard responded immediately by suggesting he could use a spreadsheet with cells for the varying numbers. He followed up this in a later lesson which was not filmed. He had made a spreadsheet to illustrate  $x$  for number of clementines and  $y$  for number of pupils, naming cells and make a transition to algebraic expression.

In the next workshop Rikard reported his implementation of the tasks in a small group session in which the participants were mostly the same as previously. The task of the clementines, and a spreadsheet that Rikard had prepared to follow up in his class were discussed. In the group session further ideas were discussed, now aiming at developing inquiry approaches to Pythagorean Theorem. These ideas were followed up in a couple of brief informal conversations between Aud and Rikard when they met some days later and led into further work on development for Rikard's class and presentation in plenary in a later workshop. Rikard later reflected "Think

about the one that you gave me on Pythagoras, you perceive something different from a question. You were into Vygotsky towards me, which created learning with me.” (Note: quotations are translated from Norwegian).

We note in the foregoing account Rikard’s alignment with the goals and activities of the project. In particular, that he was willing to take risks in developing and implementing ideas presented in workshops. The risks involved should not be underestimated. He had not tried tasks of the Fermi type before. The class was fairly new to him, and also was not familiar with this kind of tasks. In our experience the uncertainties created by these areas of unfamiliarity would put off many teachers. Rikard was prepared to take the further risk of inviting colleagues and teachers from other schools to his lesson!

### **INQUIRING INTO RIKARD’S ACTIONS**

So far we have presented the briefest outline of the events that occurred. We now move on to consider what can be learned from this. The events stood out for us, they were marked as being out of the ordinary, why was this? We offer a number of possible reasons, perhaps all contributed to a certain extent. First, we note Rikard’s invitation to his lesson. This is a practice that we aspire to in the project but as yet it is fairly unusual. Thus we want to learn from this event how we might stimulate similar sharing including the teachers. Second, we note Rikard’s apparent enthusiasm to try out this type of open task. What was it that inspired his enthusiasm for the task? What can we learn from this that will enable us to generate similar levels of enthusiasm amongst other teachers in the project. Third, we note the unusual features of ‘Fermi’ type problems, how did Rikard see these as contributing to teaching and learning in his class? Was he attracted by the novelty of the type of task or did he see the task as consistent with his own model of teaching and learning? Fourth, we see that teachers who introduce such radically different tasks with their class are taking a risk, what were the conditions in which Rikard was prepared to take such a risk with his class? These are questions that we, didacticians, pose to inform our own practice. However, we also want to expose evidence of Rikard inquiring into his own practice and the affordances that induce critical reflection. The naturally occurring data provides a sound evidential basis for exploring the context, and from discussions in small groups and conversations between teachers and didacticians we can begin to infer answers to our questions. However, we reach a point where a more formally based discussion with the teacher is needed. Consequently, we arranged with Rikard to meet him to conduct a semi-structured interview. Lead questions were prepared in advance and sent to Rikard, further prompt questions were also prepared, which were not sent. Prior to the interview Rikard prepared a written response to some of the questions.

What inspired Rikard’s enthusiasm to use these open tasks?

Rikard explained that he wants the pupils to move away from thinking about mathematics merely as a matter of finding out what to do with the numbers in a given task, i.e. looking for the ‘right’ procedure or algorithm and plugging in the numbers.

By providing problem tasks without numbers, he believed, would focus the pupils on the meaning and sense of the task. He further explained that as the class was still fairly new to him, he saw the ‘Fermi’ type tasks as a means to challenge the pupils’ conception of learning mathematics. The implementation of the tasks in his class that required pupils to report to the whole class and write a reflection on their thinking was a means of further emphasising the focus on meaning and understanding.

Rikard explained that he developed a socio-cultural view of learning as a result of his earlier teaching experiences. He referred to his work in a different school in which he had a class of pupils from several grade levels. The experience had led him to read a thesis about mixing pupils on different age levels. This led him to the work of Vygotsky and the notion of the zone of proximal development, and to Bruner and the notion of scaffolding. Rikard perceived in the ‘Fermi’ problems the potential for motivating discussion between pupils. We want to note here that the prepared questions did not invite comments about learning theory, these were volunteered by Rikard, moreover, unprompted, he returned to this theoretical underpinning several times during the interview.

Rikard shared a model of teaching and learning mathematics which he holds in common with his colleagues in the school. The model entails a three stage process- 1: experience through mathematical activity; 2: mathematical discussion; and 3: practice leading to proficiency. He seeks a questioning, searching, researching, investigating, wondering learning community in mathematics in his class. Rikard explained four possible approaches that mathematics teachers could take- 1: do nothing, only observe; 2: ask questions; 3: give hints; and 4: give solutions. For Rikard it is important to use approaches 2 and 3 - ask questions and give hints.

We interpret from Rikard’s responses that his implementation of the open tasks in his class was a carefully considered action that was based upon his knowledge, beliefs and experience in teaching mathematics. He reveals an espoused theory of learning and teaching within which open tasks are not merely consistent by positively beneficial to learning. He expressed a view of mathematics that transcends instrumental understanding and seeks principled knowledge. He also reveals sensitivity to the development of students’ metaconcept of mathematics, and the potential of the tasks to develop this in a direction that he valued.

## **CONCLUSION**

We believe in this case there is clear evidence of ‘inquiry as a way of being’ in Rikard’s professional practice. Especially in respect of the risks he was prepared to take in trying out something new. However, the risks were taken not in order to achieve some type of ‘professional thrill’. Rather, they were taken in the context of Rikard’s theoretical model of teaching and learning, his beliefs about mathematical activity, and his pedagogical intentions for his class. These three factors appear to us to be crucial affordances in Rikard’s inquiry focused actions. We also want to draw attention to the presence of the project community which prompted Rikard’s actions

in this case, provided a context for the development of ideas and a place where he could report his actions.

As we critically reflect on our own practice as didacticians, we note the significance of Rikard's apprehension of theory. We see that it is insufficient only to motivate 'inquiry' through suitable tasks. It is also important for us to work with teachers in developing their models of teaching and learning, and the theoretical underpinning of these models, which emerges to be so significant in Rikard's rationalisation of his actions.

## References

- Brousseau, G. (1997). *The Theory of Didactical Situations in Mathematics: Didactique des Mathématiques, 1970-1990*. (N. Balacheff, M. Cooper, R. Sutherland, & V. Warfield, Trans.). Dordrecht, Holland: Kluwer/Springer.
- Edwards, D. & Mercer, N. (1987). *Common Knowledge: The Development of Understanding in the Classroom*. London: Routledge.
- Gravemeijer, K. (1994). Educational development and developmental research in mathematics education. *Journal for Research in Mathematics Education*, 25(5), 443-471.
- Jaworski, B. (2004). Grappling with complexity: Co-learning in inquiry communities in mathematics teaching development. In M. Johnsen Høines & A. B. Fuglestad (Eds.), *Proceedings of the 28th Conference of the International Group for the Psychology of Mathematics Education* (Vol. 1, pp. 17-36). Bergen, Norway: Bergen University College.
- Jaworski, B. & Goodchild, S. (2006). Inquiry community in an activity theory frame. In J. Novotná, H. Morová, M. Krátká, & N. Stehlíková, (Eds.), *Proceedings of the 30th Conference for the International Group for the Psychology of Mathematics Education*, Prague, Charles University Prague.
- Potter, J. (2002). Two kinds of natural. *Discourse Studies*, 4(4), 539-542.
- Prestage, S. & Perks, P. (2001). *Adapting and Extending Secondary Mathematics Activities New Tasks for Old*. London: David Fulton Publishers.
- Stenhouse, L. (1979/1983). Research as a basis for teaching: Inaugural lecture, University of East Anglia, February 1979. In L. Stenhouse (Ed.), *Authority, Education and Emancipation* (pp. 177-195). London: Heinemann Educational.
- Swan, M., & Ridgway, J. (n.d.). Classroom assessment techniques 'plausible estimation tasks [Electronic Version]. Retrieved 17 December, 2007, from <http://www.flaguide.org/cat/math/estimation/estimation7.php>
- Wagner, J. (1997). The unavoidable intervention of educational research: A framework for reconsidering researcher-practitioner cooperation. *Educational Researcher*, 26(7), 13-22.

# **GESTURE AS DIAGNOSIS AND INTERVENTION IN THE PEDAGOGY OF GRAPHING: PILOT STUDIES AND NEXT STEPS**

Susan Gerofsky

University of British Columbia

*This paper reports findings from two pilot studies that explored variations of secondary students' gestures when asked to describe mathematical graphs. Three generic diagnostic categories emerged from this data with regard to learners' degree of imaginative engagement and ability to notice mathematically salient features when encountering graphs. Hypotheses about diagnosis and remediation through gesture in the pedagogy of graphing are formulated, to be tested in a follow-up study.*

## **GESTURE: AN EMERGENT RESEARCH AREA IN MATH EDUCATION**

Mathematics educators are working increasingly with gesture as a way of revealing unconscious aspects of mathematics learning and teaching. Teachers and learners produce gestures in a largely unconscious way, as a byproduct of communicating and expressing ideas. Gestures produced by mathematics teachers and learners provide a rich source of data, comparable in scope to that provided by language, which can be read in terms of bodily metaphors, object development in the formation of mathematical concepts, and the relationships among mathematical concepts.

A significant number of mathematics educators have turned their attention to gestures in mathematics education in recent years. Published research in this area is growing (see, for example Abrahamson, 2004; Alibali & Nathan, 2007; Arzarello & Edwards, 2005; Flevares & Perry, 2001; Goldin-Meadow, Nusbaum, Kelly, & Wagner, 2001; Graham, 1999; Lemke, 2002; Nemirovsky & Borba, 2003; Noel, 2005; Núñez, 2004; Radford, Demers, Guzmán, & Cerulli, 2003; Rasmussen, Stephan, & Allen, 2004; Reynolds & Reeve, 2003; Robutti & Ferrara, 2002; Roth, 2001), Mathematics educators have benefited by using and adapting terminology, conceptions and methods from work already in progress in the emerging field of gesture studies. Groundwork in gesture studies has arisen from interdisciplinary work over the past fifteen years involving linguistics, deaf education, computer science, cognitive neuroscience and psychology. Key researchers like McNeill (McNeill, 1992, 2005), Goldin-Meadow (Goldin-Meadow, Kim, & Singer, 1999), Kendon (Kendon, 2004), Fauconnier (Fauconnier & Turner, 2002) and Sweetser (Parill & Sweetser, 2004) have established terminology, analytic tools and research methods for a rigorous analysis of gesture.

## **ORIGINS OF THIS STUDY: PILOT STUDIES AND NEW HYPOTHESES**

Working as a linguistic/ paralinguistic researcher in mathematics education, I became interested in students' use of gesture in communicating about mathematical graphs,

as observed in classrooms where I supervised student teachers and in my own teaching practice. My initial interests included:

- variations in the placement of the  $x$ - axis in relation to the gesturer's body, and potential cognitive, cultural and semiotic interpretations of this placement,
- variations in modes of gesturing a symmetrical graph (using one or both hands, and making use of the body's bilateral symmetry or not),
- variations in eye tracking of gestured graphs,
- interpretations of time, acceleration and fictive motion in relation to the  $x$ -axis shown by gesture,
- effects of school instruction about graphs and functions on the gestures of advanced secondary math students as compared to those of novice learners in the early years of secondary school,
- genres, conventions or schemata of graph gesturing that might emerge from a reasonably large sample of gestured graphs

To explore initial hunches and generate specific hypotheses, I embarked on two pilot empirical studies of the features of the gestures students used when they described graphs, and the interpretation of these features in terms of students' mathematical thinking. Results from the pilot studies have focused this research on two new hypotheses, related to and extending my original research interests:

**Hypothesis 1:** Gestured graphs can offer the basis for a quick, concise and accurate diagnosis of students' patterns of noticing and engagement in secondary mathematics.

**Hypothesis 2:** An early intervention that leads all students to gesture graphs closer to that of the most engaged students' gestures can improve students' patterns of noticing and engagement in secondary mathematics.

This paper reports on results of the pilot studies already completed and announces an upcoming study to test Hypotheses 1 and 2 more specifically.

## **DESCRIPTION OF TWO PILOT STUDIES**

In the first exploratory pilot study, I recruited ten faculty colleagues and family members as convenient subjects, and asked each to gesture a given assortment of graphs in front of a video camera. Participants were offered 17 cards with enlargements of mathematical graphs, taken from a calculus course and chosen for their variety (symmetrical, asymmetrical and asymptotic graphs, graphs chosen for their interesting visual rhythms, and graphs situated mostly above or below the  $x$ -axis). Subjects were videotaped in individual clinical sessions. Each participant was asked to stand facing a stationary video camera on a tripod; the graph cards were placed face down on a nearby table. Subjects were asked to look at one card at a time and describe the graph using gesture, as if communicating this shape to someone who could see them but not the graph. They were instructed to make the gestures as large as they felt

comfortable with. Participants were encouraged to use vocal sounds and language to describe the graph as well, but told that they should avoid technical mathematical descriptions, since these might be accurate enough to inhibit the need for gesture.

Preliminary observations from this first pilot study included the following:

- Participants reported that they not consciously aware of the choices they made in gesturing the given graphs.
- Participants' gestural representations of the graphs varied widely with regard to placement of the axes (especially the  $x$ -axis), symmetry, acceleration, direction of movement, handedness, and large vs. small kinesthetic engagement.
- Many participants treated the  $x$ - axis as a representation of time.
- Some participants used metaphors and non-verbal vocal sounds extensively to describe the graphs. These participants also tended to use large kinesthetic motions in their gesturing. Participants whose motions were more constrained also tended to use fewer metaphoric or non-verbal vocalized descriptions.

Based on observations from this initial pilot study, I carried out a second pilot study at three Vancouver, Canada public secondary schools: an east-side school (generally low SES), a west-side school (high SES), and a centrally-located mini school that drew from the whole district (mixed SES). In each school, math teachers were asked to find three or four students willing to participate from each of Grade 8 (age 13) and Grade 11 (age 16), representing diversity in terms of gender, ethnicity, and math achievement and enthusiasm. I asked the teachers not to inform me before the sessions which students were the "keen", "poor" or "average" math students in their estimation. Grade 8 students would be novices, with little exposure to graphing in school mathematics; Grade 11 students would just have completed a year of intensive study of the graphs of functions and relations. I included the teachers of these students in the study to watch for possible transfer effects from teachers to students.

As in the earlier pilot, students started the first session standing in front of a stationary video camera on a tripod. I had chosen five of the original 17 graphs, selecting those that had elicited the most varied responses in the earlier study. As before, students were asked to look at one graph card at a time and describe it using gesture, vocal sounds and words, but not technical mathematical descriptions. I asked each participant to do three 'takes' of their gesture for each graph card, the third without words.

I returned to the schools a week later for a second videotaped session, where I conversed with each participant as we watched their earlier session. The second session gave me the chance to ask participants what they noticed about their own gestures, share with participants what I had noticed about their gestures, and ask participants for their insights into *why* they had gestured as they had.



<b>SESSION 1 (VIDEOTAPING GESTURES AT 3 SCHOOLS)</b>	<b>M</b>	<b>F</b>	<b>TOTALS</b>
Grade 8 students	5	6	<b>11</b>
Grade 11 students	5	6	<b>11</b>
Teachers	2	2	<b>4</b>
<b>Totals:</b>	<b>12</b>	<b>14</b>	
<b>SESSION 2 (RE-VIEWING AND DISCUSSING TAPES)</b>			
Grade 8 students	3	4	<b>7</b>
Grade 11 students	3	1	<b>4</b>
Teachers	2	2	<b>4</b>
<b>Totals:</b>	<b>8</b>	<b>7</b>	

Figure 1.

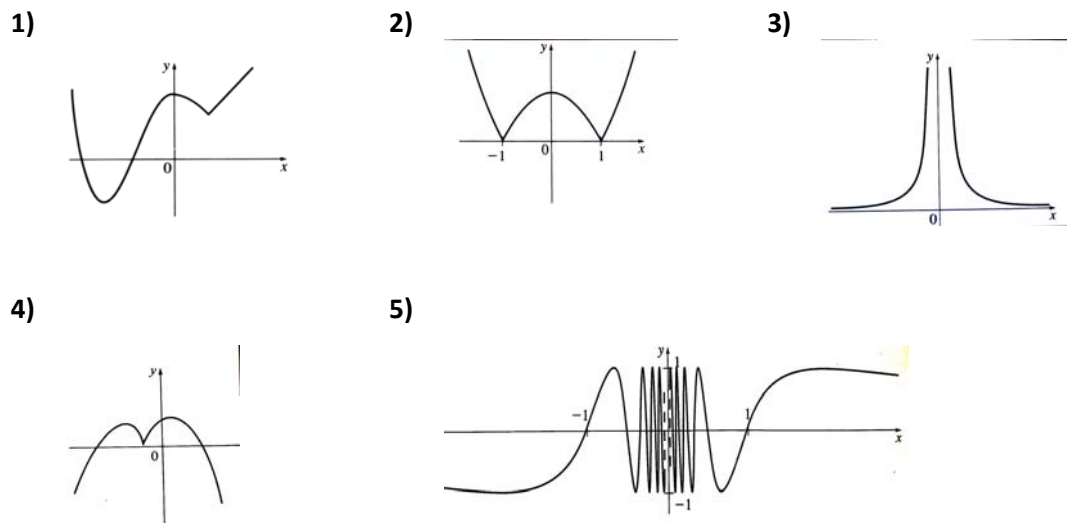

Figure 2. The five graphs used in the second pilot study (in schools).

### **AN EMERGENT DIAGNOSTIC PATTERN IN GESTURED GRAPHS**

My observations of students' gestured graphs showed a range of variations in terms of the features of initial interest: placement of the  $x$ -axis in relation to the body, treatment of the  $x$ -axis as the time axis, symmetrical or sequential gesturing of graphs, and so on. These individual features seemed to cluster in three generic categories, and each participant's collection of gestured graphs fell predominantly into one of these:

1) An **“arm’s-length visual model” of the graph (11 of 22 students)**: These gestured graphs involved small movements of a finger, hand and arm, without a great deal of larger kinaesthetic movement involving the spine. For these students, it was as if they were tracing a small graph on a vertical pane of glass or sheet of paper in front of their upper body, using a finger-tip ‘pencil’. Students in this group were the

most likely to emphasize accuracy above all. These students would often indicate the locations of the horizontal and vertical axes before they began gesturing, and would take pains to place particular numerical values on their ‘air graph’ and to draw or redraw their gestured graph so that it accurately passed through the correct values.

These students placed the  $x$ -axis relatively high on the body (at heart, shoulder, throat or nose level) and used a single finger on their dominant hand to make a rather restrained gesture of the graph. Many of these students said in the follow-up interview that they wanted to place the graph where they could *see* it (within their peripheral vision, without moving their heads from a central looking-forward position). Most of these students tracked the imaginary graph with eye movement.

This group of students included those who were the slowest to gesture their graphs. In taking pains to make sure their gestures were correct, some of these students moved very slowly, without acceleration, and even made ‘erasing’ gestures before redoing their gestured graphs. All of the students who did not treat the  $x$ -axis as the time axis belonged to this group (although many in this group did treat the horizontal axis as a representation of time).

**2) “Being the graph/ being in the graph” (9 of 22 students; 4 of 4 teachers):**

These gestured graphs involved noticeable movement of the spine, and often markedly kinesthetic, whole-body movements. Some students’ gestures required them to reach, move off balance or take a step or two. Most of these students used their whole hand or arm, rather than a single finger, to make the gesture, and several used two hands held palm-to-palm, as if preparing to dive into water. One student’s gesture was very much a gesture of diving, as if he were following the shape of the graph with his whole body through water.

Students in this group were notable for their bodily, visceral engagement with the shape of the graph. It appeared as though they were ‘in’ the graph, experiencing the fluctuations of its shape as a movement or journey along a trajectory. Even when gesturing a symmetrical graph with both hands, students in this group would bend, reach and stretch their bodies as if they were touching or riding along the graph.

Most students in this group placed the  $x$ -axis relatively low on their bodies (from heart-height to waist- or hip-height). This placement, combined with knee-bending and reaching, allowed them to achieve a whole-body representation of the graph more or less within *reach* (contrast with the first group, who wanted to have the graph appear within *sight*).

Notably, and particularly for the Grade 8 students in this gesture category, these large gestures were very frequently accompanied by verbal metaphors describing the graphs’ shapes in terms of other familiar objects or phenomena. Some of the students in this group produced long strings of metaphors for each graph, which offered contrasting analogies that could function as ‘tools for thinking’ about different features of the graph and its underlying mathematics. For example, one of the Grade 8 students described Graph 4 as follows:

This one looks like a round M, or two blobs of jello stuck together, or like when you were in kindergarten and you drew birds, you always draw them as an M. Looks like a kindergarten M or a birdie, like when you draw crows in the sky... Round, two hills again, kind of. And then, two jello blobs, one big, one small, beside each other...yeah. Looks like a 3, but then turned...turned somehow (gestures and turns head and shoulders to one side.) And then, looks kind of like, there's this little bomb thing, and then it shoots out, shoots outwards.

These students were also the most likely to use non-verbal vocalizations to represent the fictive 'motion' of the graphs.

3) **“Inaccurate, not aware of what counts as salient” (2 of 22 students):** These students had difficulty producing gestures for the graphs, hesitating repeatedly or rushing through the task. Gestural movements did not correspond accurately to the shapes of the graphs, and often large sections of the graph were omitted. Successive 'takes' of the same graph often differed wildly. These students sometimes tried to produce two-handed, symmetrical gestures to represent asymmetrical graphs, produced 'pointy' gestures for rounded curves or vice-versa, and often picked up the graph cards between takes to stare at them at close range. These students produced metaphors for portions of a graph (for example, describing a shape as a 'half pipe', 'hill' or 'checkmark'), but not for its overall shape.

It appeared that these students were encountering two kinds of difficulties: a struggle with perceiving each graph in its overall shape (as a unified entity rather than a collection of parts), and a lack of schemata for identifying and interpreting mathematically salient features of the graphs (relative heights of maxima/ minima, axis crossings, discontinuities, symmetries or asymmetries, etc.)

An informal conversation with one of the teachers after the first session seems to reify these categories as potential diagnostic categories. The teacher asked me if I could identify which students she had selected for the study as 'average, hard-working B-level math students', 'top, highly creative A students', and 'struggling, at-risk students'. It was surprising that, after spending just five minutes videotaping each student as they gestured graphs, I accurately identified the students in category 1 (above) as the 'average' students, category 2 as 'top' students, and category 3 as 'struggling' students. I hypothesize that:

- Category 1 students were precise and followed rules carefully, but often depended on memorization and algorithmic thinking rather than engaging fully with math concepts. These students had learned to value specificity, accuracy and correctness as the principle features that would lead to success in mathematics class and perhaps even the principle features that characterized mathematics as a discipline. An overriding focus on precision and accuracy seemed to offer students in the first group a singular, 'one-way' and somewhat rigid approach to a graph (or other mathematical concept). Keeping mathematical ideas 'at arm's length' gave them a sense of control and correctness, but at the cost of full imaginative engagement.

- Category 2 students' visceral, experiential approach to the graphs and multiple metaphors and verbal/kinesthetic/visual representations allowed them multiple potential entry points for sense-making and the creation of more robust mathematical conceptual objects. These students' whole-body engagement seemed to offer a way to bring somatic and imagistic imagination into play in their mathematics. Accuracy was not discounted or sacrificed here, but it was not treated by these students as the most salient feature of their exploration of the graphs. Students in the second group showed a conceptually flexible approach to mathematics learning.
- Category 3 students were in urgent need of help in learning to see graphs as whole objects and in bringing attention to those features of graphs considered mathematically salient. Both of the students identified in category 3 were in Grade 8, at the start of their secondary school career. If they were to carry on learning mathematics in mainstream classes, immediate remediation was needed.

In designing the next part of this study, I will focus on the following questions:

Could a five-minute session with each student gesturing graphs work as an accurate diagnostic tool for mathematical 'noticing' and 'imagining' abilities?

Could gesture-based interventions be developed to improve these abilities (for the whole class, small groups and individual learners)?

Can students develop mathematical concepts by reading graphs directly with the body? If so, can this 'gestural literacy' be developed and educated?

## References

- Abrahamson, D. (2004). Embodied spatial articulation: A gesture perspective on student negotiation between kinesthetic schemas and epistemic forms in learning mathematics. In D. E. McDougall & J. A. Ross (Eds.), *Proceedings of the 26th Meeting of PME-NA*, Vol. 2, 791 - 797. Toronto: Preney.
- Alibali, M. W. & Nathan, M. J. (2007). Teachers' gestures as a means of scaffolding students' understanding: Evidence from an early algebra lesson. In R. Goldman, R. Pea, B. Barron, & S. J. Derry (Eds.), *Video Research in the Learning Sciences*. Mahwah, NJ: Erlbaum.
- Arzarello, F. & Edwards, L. (2005). Gesture and the construction of mathematical meaning. In H. L. Chick & J. L. Vincent (Eds.). *Proceedings of the 29th Conference of IGPME*, (Vol. 1, pp. 123-154). Melbourne: PME.
- Fauconnier, G. & Turner, M. (2002). *The Way we Think: Conceptual Blending and the Mind's Hidden Complexities*. New York: Basic Books.
- Flevaris, L. M. & Perry, M. (2001). How many do you see? The use of nonspoken representations in first-grade mathematics lessons. *Journal of Educational Psychology*, 93, 330-345.
- Goldin-Meadow, S., Kim, S., & Singer, M. (1999). What the teacher's hands tell the student's mind about math. *Journal of Educational Psychology*, 91(4). 720-730.

- Goldin-Meadow, S., Nusbaum, H., Kelly, S. D., & Wagner, S. (2001). Explaining math: Gesture lightens the load. *Psychological Science, 12*(6), 516-522.
- Graham, T. (1999). The role of gesture in children's learning to count. *Journal of Experimental Child Psychology, 74*, 333-355.
- Kendon, A. (2004). *Gesture: Visible Action as Utterance* Cambridge. UK: CUP.
- Lemke, J. L. (2002). Mathematics in the middle: Measure, picture, gesture, sign, and word. In M. Anderson, A. Saenz-Ludlow, S. Zellweger, & V. Cifarelli (Eds.), *Educational Perspectives on Mathematics as Semiosis*, 215-234. Ottawa: Legas Publishing.
- McNeill, D. (1992). *Hand and Mind: What Gestures Reveal about Thought*. Chicago: University of Chicago Press.
- McNeill, D. (2005). *Gesture and thought*. Chicago: University of Chicago Press.
- Nemirovsky, R. & Borba, M. (2003) Perceptual-motor activity and imagination in mathematics learning. In N. Pateman, B. Dougherty, & J. Zilliox (Eds.). *Proceedings of the Conference of PME27 -PMENA25*, Honolulu, HI: University of Hawaii.
- Noel, M. P. (2005). Finger gnosia: a predictor of numerical abilities in children? *Child Neuropsychology, 5*, 413-430.
- Núñez R. (2004). Embodied cognition and the nature of mathematics: Language, gesture, and abstraction. In K. Forbus, D. Gentner, & T. Regier (Eds.) *Proceedings of the 26th Annual Conference of the Cognitive Science Society*, (pp. 36-37). Mahwah, NJ: Erlbaum.
- Parrill, F. & Sweetser, E. (2004). What we mean by meaning. *Gesture (4)*2, 197-219.
- Radford, L., Demers, S., Guzmán, J., & Cerulli, M. (2003). Calculators, graphs, gestures, and the production of meaning. In N. Pateman, B. Dougherty, & J. Zilliox (Eds.), *Proceedings of the Conference of PME27 - PMENA25* (Vol. 4, pp. 55-62). Honolulu, HI: University of Hawaii.
- Rasmussen, C., Stephan, M., & Allen, K. (2004). Classroom mathematical practices and gesturing. *Journal of Mathematical Behavior, 23*, 301-323.
- Reynolds, F. J. & Reeve, R. A. (2002). Gesture in collaborative mathematical problem-solving. *Journal of Mathematical Behavior, 20*, 447-460.
- Robutti, O. & Ferrara, F. (2002). Approaching algebra through motion experiences. In A. D. Cockburn & E. Nardi (Eds.), *Proceedings of the 26th IGPME Conference*, (Vol. 1, pp. 111-118).
- Roth, W-M. (2001). Gestures: Their role in teaching and learning. *Review of Educational Research, 71*, 365-392.

# **BUILDING CONNECTED UNDERSTANDING OF CALCULUS**

Hope Gerson and Janet G. Walter

Brigham Young University

*In the winter of 2006 the authors conducted a teaching experiment in which 22 students explored cognitively important, multiple-response calculus tasks. Students were encouraged to collaboratively develop multiple solution strategies and to justify their answers without prior instruction. In a larger study we examine from a cognitive lens of conceptual blending the connected understandings calculus students built as they engaged in the Quabbin Reservoir Task. Here we present one student's emerging connected understanding of quantity represented by the area under the rate curve.*

Connected understanding has been an increased focus in recent years (Gerson, 2008; Hahkionemi, 2006; Marrongelle, 2004; Speiser, Walter & Maher, 2003; Walter & Gerson, 2007; Zohar, 2006). The nature of connections that students build, particularly within inquiry-based classrooms, has not been clearly characterized.

## **THEORETICAL FRAMEWORK**

### **Agency**

Students learn through the exercise of personal agency, or the “requirement, responsibility and freedom to choose based on prior experiences and imagination, with concern not only for one’s own understandings of mathematics, but with mindful awareness of the impact one’s actions and choices may have on others.” (Walter & Gerson, 2007, p. 210). Through sustained mathematical inquiry, students activate their agency by making choices and engaging in problem solving activities with a high level of motivation, and a sense of enthusiasm as ideas are built and justified (Cifarelli & Cai, 2005, Zaslavsky, 2005). As we look at the problem solving activities in which students engage, it is important to recognize the personal choices that are made (Walter and Gerson, 2007, Martin, Sugarman, & Thompson, 2003).

Cifarelli and Cai (2005) further suggest that mathematical exploration involves sense making, problem posing and problem solving in a recursive process of engaging, reflecting, and formulating new questions. Students build meaning and understanding from their previous experiences, so at any time, students’ reasoning and sense making is advancing or progressing (Rasmussen, Zandieh, King and Teppo, 2005) and thus it is important to recognize that different students will make different choices at different times, strongly grounded in their previous experiences.

### **Connections**

Students’ sense-making and understanding of mathematics necessarily include both content and connections among content (Gerson, 2001; Rasmussen, et.al., 2005). We suggest that analyzing both understandings of foundational calculus content and connections students make amongst content, context, and previous knowledge will

give us a richer picture of the emergent meanings students are creating as they explore meaningful mathematics tasks.

### **Conceptual Blending**

Conceptual Blending (Fauconnier & Turner, 2002) is a cognitive theory which illuminates the construction of meaning. Fauconnier and Turner (2002) suggest that human beings create new meaning through a process of conceptual blending where two input spaces are combined to form a blended space making new relations available that are not present in the input spaces. The blended space is a creative and imaginative combination of the input spaces with its own emergent structure resulting in “genuine novel integrated action.” (p. 35).

It should be noted that conceptual blending is a cognitive theory that is used to describe sense-making for one individual at a time. While individual blends can translate to the society at large and can be shared by more than one person, the theory of blending is mostly concerned with the sense-making acts of the individual. We do not claim access to students’ individual thoughts, but by mapping the blends students create, we gain deeper insight into the connections that students are explicitly making as evidenced by their language, gestures, written inscriptions, emotions, etc. We believe that viewing the mathematical connections along with the construction of meaning that follows through the lens of conceptual blending will allow us to focus on both content and connections to more fully characterize the student’s construction of meaning.

The emergent structure of the blend is generated in three ways: composition, completion and running the blend. Composition is making a connection between the two input spaces that continues into the blend. Completion is used when a frame is invoked in one of the spaces and continues into the blend. Completing the frame, in the blended space, results in new ideas in the blend. Running the blend involves imagining a simulation running in the blend and seeing what new insights emerge (Fauconnier & Turner, 2002).

### **BRIEF REVIEW OF RELEVANT LITERATURE**

Schnepf and Nemirovsky (2001) helped students to activate cognitive, linguistic, and kinesthetic resources” to build connected understandings of representations of motion. They introduced differentiation and accumulation of area simultaneously through a series of tasks using Simcalc. This allows students to build the inverse relationship between rate and area before encountering the Fundamental Theorem of Calculus. Marrongelle’s (2004) students also created contexts from which to make sense of calculus content using physical experiences with motion. Physical experiences with a motion detector were found to be important for each student’s understanding of the derivative. Speiser, Walter, and Maher (2003) studied the organic development of a sense for how to represent the motion of a cat as depicted in a series of still photographs. As students built graphical representations of the motion of the cat, they built connected understandings of displacement, velocity, and acceleration and connected the new knowledge to their previous classroom instruction.

## RESEARCH METHODOLOGY AND QUESTION

### Setting

In winter, 2006, the authors conducted a teaching experiment in which 22 university honors calculus students explored cognitively important, multiple-response calculus tasks. Students were encouraged to collaboratively develop multiple solution strategies and to justify their answers without prior instruction. Pedagogical decisions were based upon ideas that students brought forward rather than predetermined trajectories. As each new task was given, the students collaboratively improvised their own understandings of the questions, representations, solution strategies, and the language they would use to represent various emergent mathematical ideas. At the instructors' discretion, groups of students were asked to present their ideas and were questioned by the class and the instructors. Students' activation of agency was recognized as necessary for the learning process, and therefore, students' ideas were highly valued and pursued.

### Task

Students began working on the Quabbin Reservoir Task five weeks into the semester after previously working on two other tasks. Immediately prior to this task, students had built understandings of the definition of derivative, limits and continuity.

In the Quabbin Reservoir Task students were given graphs (Figure 1) of inflow and outflow of water in Boston's Quabbin Reservoir as a function of time and asked to reason about the quantity of water in the reservoir.

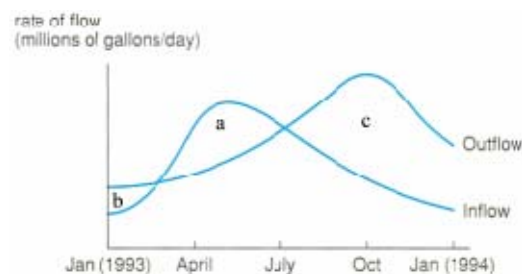

Figure 1. Graphs for the Quabbin Reservoir Task (labels added).

### Method

A grounded theory (Strauss & Corbin, 1998) approach was used to analyze three hours of videotape collected within two class periods, where four students explored the Quabbin Reservoir Task and presented their ideas to the class. The videodata were transcribed and independently verified by members of the research team. Next video, transcript, and original student work, were examined in a multilayer analysis. Key episodes in which students were working with or articulating understanding of rate or antiderivative and its connections to quantity were identified, formed into clips, organized chronologically within each mathematical topic, and coded. In addition, groups of episodes were analyzed by creating maps of conceptual blends for



individual students' and groups of students' understandings of each topic. These maps became part of the data being analyzed. Video and transcripts were viewed together throughout and existent and emergent theories were triangulated with all data sources resulting in a multilayered analysis supported by strong evidence.

**Question**

What understandings of important calculus content did students build while engaging in the Quabbin Reservoir task?

**DATA AND ANALYSIS**

Jay first began to draw the net flow, called it quantity and asserted that the quantity was “negative...because there is more outflow than inflow.

Jay: Okay, so we start out negative. Uh.

Shaun: Well it starts out moving downward, so moving in a negative direction yeah.

Jay: Well it starts out like the first value is a negative because there is more outflow than inflow.

After discussion, Jay chose to shift up his graph to reflect a starting quantity. However, he continued to graph the netflow as the quantity (Figures 2 and 3).

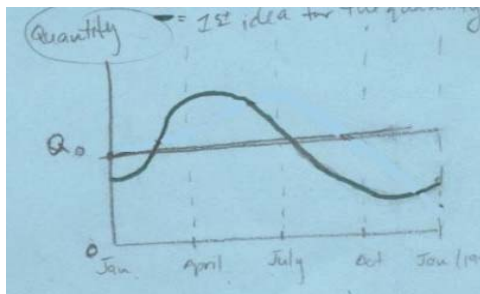

Figure 2. Jay's "Quantity" Graph.

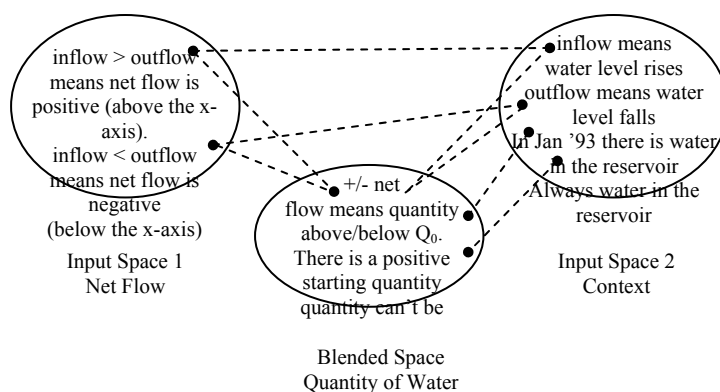

Figure 3. Jay's Blend for Quantity of Water.

The emergent structure of Jay's blend is that the quantity of water in the reservoir is the same as the netflow translated up to a starting quantity  $Q_0$ . When it comes time to answer question (c) which asks the students to compare the quantities of water in the reservoir in Jan '93 with Jan '94, Jay completed the blend and concluded that he just

needed to compare the netflow in Jan '93 and Jan '94. This resulted in a discrete comparison between rate of flow and quantity.

Jay: How does January ninety-four compare with the quantity in ninety-three? They look to be about the same inflow, but the outflow is really different

After Jay began to compare the quantities of water at the beginning and end of the year, still reasoning discretely, Shaun suggested that they could also determine the quantity of water in the reservoir by comparing the areas between the inflow and outflow curves (See Figure 4).

When later Shaun and Jay disagreed about how much water was in the reservoir at the end of the year, instead of returning to his own reasoning with netflow, Jay chose to use areas to justify Shaun's answer and disprove his own.

Jay: Okay, well look at this. Just look at that section with this section put together and I think you're right because...that little bowl (a)...That's all the gain in inflow...And then that bowl (b), then that bowl (c) are all the outflow, so I think you are right (Figure 1).

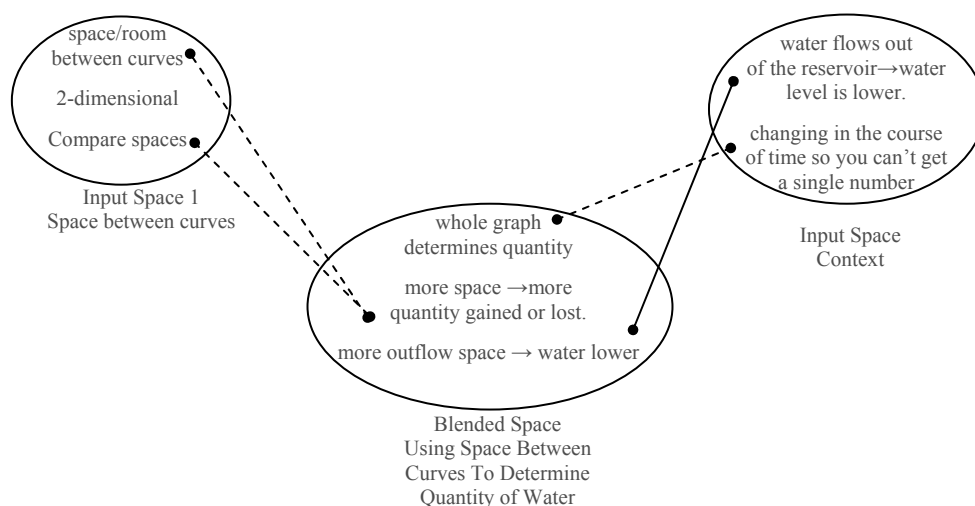

Figure 4. Jay's New Blend for Quantity Using Space Between Curves.

In the course of Jay's justification, he used a metaphor of a bowl as a container for the area between the curves. Jay built a three-way connection amongst the area between the inflow and outflow of water, a bowl as a container, and the quantity of water in the reservoir.

Jay later made more and stronger connections as he built his understanding of quantity by reasoning about the area between curves.

Jay: Okay, I got one. Definitely not that one. Okay, as far as my curvature went, I just kind of visualized in my head it's zero point you know where it's evened out is probably right before April so I, you know right before April, had it zero out so that would mean, you know, it's

Shaun: Yeah.

Jay: It's overall quantity is just a little above April, or a little above the line

Shaun: Hum, hum

Jay: Toward's July it's increasing, but it's increasing, it's acceleration, I don't, I hate saying that, but it's like rate of flow kind of thing, it's going down and so the curve is going up because it's having less increase over time and so it's having less and so it's leveling out. And from July to October, I said at September was about the point where, you know it's close to Oct, it's closer to October than it is to July where it hits the starting quantity again.

After 50 minutes of engagement with the task, Jay had drawn a correct graph of the quantity of water in the reservoir using a conception of area between curves that developed out of his use of the bowl metaphor and group discussions. He was able to re-draw his quantity graph explaining and justifying the critical points and the behavior in each quarter based upon his reasoning about the area between curves.

## **CONCLUSION**

As in the studies discussed in the literature review (Schnepp & Nemirovsky, 2001; Marrongelle, 2004; Speiser, Walter, & Maher, 2003) the students in the teaching experiment built connected understandings of conceptually important calculus content. Like Schnepp's and Nemirovsky's students, these students built understandings of derivatives, area, and accumulation of area as well as antiderivatives before encountering the Fundamental Theorem of Calculus. Like the Kenilworth students (Speiser, Walter, & Maher, 2003), these students engaged in sustained inquiry of open response tasks to build connected understanding. And like Marrongelle's students, our students' previous experiences with motion and context played a strong role in their development of important calculus content. Our class was different in that there was very little teacher intervention or prior instruction; the students' agency and inquiry played the central role in the content and pedagogical decisions made in the course. Students had the freedom to choose their own ways of making sense of the tasks and building understanding of calculus. Through sustained improvisational inquiry on the Quabbin Reservoir task, Jay and his classmates, over time, developed a correct conception of the quantity of water in the reservoir. In the process they built connected understandings of antiderivatives, concavity, critical points, area between curves, and accumulation of area. The students employed these understandings in the next task to develop the Fundamental Theorem of Calculus. Thus students given the freedom to choose the direction of inquiry with little teacher intervention can build for themselves strong connected understandings of calculus.

## **FURTHER DIRECTIONS**

There is a growing body of research in Calculus that shows evidence of students creating connected understandings especially of derivatives. In our research we are trying to more fully characterize connected understanding of calculus concepts, including derivatives, antiderivatives, concavity and ultimately the Fundamental Theorem of calculus.

## References

- Cifarelli, V.V., & Cai, J. (2005). The evolution of mathematical explorations in open-ended problem-solving situations. *Journal of Mathematical Behavior*, 24, 302-324.
- Fauconnier & Turner (2002). *The Way We Think: Conceptual Blending and the Mind's Hidden Complexities*. New York, NY: Basic Books.
- Gerson, H. (2008) David's Understanding of Functions and Periodicity. *School Science and Mathematics*, 108 (1), 28-38.
- Hahkionemi, M. (2006). Associative and reflective connections between the limit of the difference quotient and limiting process. *Journal of Mathematical Behavior*, 25(2), 170-184.
- Hughes Hallet, D. (1994). *Calculus*. New York, NY: John Wiley & Sons, Inc.
- Martin, J., Sugarman, J., & Thompson, J. (2003). *Psychology and the Question of Agency*. State University of New York Press, Albany.
- Marrongelle, K. A. (2004). How students use physics to reason about calculus tasks. *School Science and Mathematics*, 104 (6), 258-72.
- Rasmussen, C., Zandieh, M., King, K., & Teppo, A. (2005). Advancing Mathematical Activity: A Practice-Oriented View of Advanced Mathematical Thinking. *Mathematical Thinking and Learning*, 7(1), 51-73. Lawrence Erlbaum Associates, Inc.
- Schnepp, M. J. & Nemirovsky, R. (2001). Constructing a foundation for the fundamental theorem of Calculus. In A. A. Cuoco & F. R. Curcio (Eds.), *The Roles of Representation in School Mathematics*, 2001 Yearbook (pp. 90-102). Reston, VA: National Council of Teachers of Mathematics.
- Speiser, R., Walter, C., & Maher (2003). Representing motion: An experiment in learning. *Journal of Mathematical Behavior*, 22(1), 1-35.
- Strauss, A. & Corbin, J. (1998). *Basics of Qualitative Research Techniques and Procedures for Developing Grounded Theory* (2<sup>nd</sup> ed.). California: Sage.
- Walter, J. G. & Gerson, H. (2007). Making sense of slope through recursion: Lyn's story. *Educational Studies in Mathematics*, 65, 203-233.
- Zaslavsky, O. (2005). Seizing the opportunity to create uncertainty in learning mathematics. *Educational Studies in Mathematics*, 60(3) pp. 297-322.
- Zohar, A. (2006). Connected knowledge in science and mathematics education. *International Journal of Science Education*, 28(13) 1579-1599.



# PROCESS- AND OBJECT-BASED THINKING IN ARITHMETIC

Camilla Gilmore and Matthew Inglis

University of Nottingham

*Many influential theorists have proposed that learners construct mathematical objects via the encapsulation (or reification) of processes into objects. These process-to-object theories posit that object-based thinking comes later in the developmental path than process-based thinking. In this paper we directly test this hypothesis in the field of early arithmetic. An experiment is reported which studied 8 and 9 year-old children's use of the inverse relationship between addition and subtraction. We demonstrate that a subset of children were unable to solve arithmetic problems using process-based thinking, but that, nevertheless, they were able to use the inverse relationship between addition and subtraction to solve problems where appropriate. The implications of these findings for process-to-object theories are discussed.*

## PROCESS-OBJECT THEORIES IN MATHEMATICS EDUCATION

Throughout the history of mathematics education research, many theorists have proposed that a key component of coming to know mathematics is related to the encapsulation, or reification, of processes into objects (e.g. Davis, 1984; Dienes, 1960; Dubinsky, 1991; Gray, Pitta, & Tall, 1999; Gray & Tall, 1994; Piaget, 1985; Sfard, 1991). During the 1990s several influential theorists developed specific theories which state that students come to learn mathematics, and in particular arithmetic, in this way. These theories are in wide use for analysing mathematics learning, and designing instruction (e.g. Dubinsky, Weller, McDonald, & Brown, 2005; Tall, 2007; Weber, 2005). During the 1990s, three major flavours of process-object theories became influential in the field.

Sfard (1991) spoke of a three stage process to concept development. First, she claimed, comes the interiorization stage: a process or operation is performed on a familiar mental object. If a learner is able to consider the process without actually performing it, they are said to have interiorized it. Later, the learner may 'reify' the process. Reification was described as a sudden "ontological shift" when the learner sees a familiar object in a new light: the process becomes a static structural object, and can serve as the base object for further, more advanced, processes.

Dubinsky (1991; Cottril et al, 1996) proposed an essentially identical developmental path in what became known as APOS theory. The APOS theorists suggested that objects (O) are encapsulated processes (P), which in turn are interiorised actions (A). In some cases learners may coordinate a series of objects, processes and actions into schemas (S). The developmental path was claimed to follow the acronym of the theory's name: A first, followed by P, O and S.

Gray and Tall (1994) agreed with the process/object dichotomy proposed by Sfard (1991) and Dubinsky (1991), but extended it by emphasising the importance of

mathematical symbolism. Defining a procept as a symbol which flexibly and ambiguously represents both process and object, they claimed that a key barrier to success in mathematics learning was bridging the proceptual divide. That is to say that children must successfully be able to encapsulate processes into objects and flexibly move between these two conceptualisations using ambiguous symbolism.

Although the process-object theorists agreed that once encapsulation has been achieved learners can flexibly move between process and object conceptualisations, they differed somewhat about the ordering of the two parts to concept understanding. Gray and Tall (1994) made no strong claims about the ordering of process- and object-based thinking. But both Sfard (1991) and Cottril et al (1996) made explicit predictions, claiming a distinct ordering of the process and object conceptions (operational and structural conceptions in Sfard's terms). They suggested that the process came first, followed by the object:

We have good reasons to expect that in the process of concept formation, operational conceptions would precede the structural (Sfard, 1991, p. 10).

An object is constructed through the encapsulation of a process (Cottril et al, 1996, p. 171).

In this sense both APOS and Sfard's reification can be said to be process-to-object theories of mathematical development. Our goal in this paper is to question the universality of this ordering in children's arithmetic development. We will argue that a subset of children actually exhibit a different developmental path in the domain of arithmetic. To proceed with this argument we first consider the nature of object-based thinking (also called structural or conceptual thinking), and how it can be operationalised for the empirical researcher.

### **WHAT IS OBJECT-BASED THINKING?**

A key component to testing the developmental route proposed by process-object theorists is operationalising the notion of object-based thinking. Davis (1984) clearly described the distinction:

The procedure, formerly only a thing to be done - a verb - has now become an object of scrutiny and analysis; it is now, in this sense, a noun (p. 30).

But how can the researcher determine whether a student is using process- or object-based thinking? Clearly an operationalisation which merely attributes object-based thinking to those who succeed and process-based thinking to those who fail will lead to circularity. Sfard (1991) recognised this problem, but failed to offer a solution, instead she claimed that "it is practically impossible to [...] formulate exact definitions of the structural and operational ways of thinking" (p. 4). But this is an unsatisfactory situation: without exact definitions of these terms, or at least exact operationalisations within restricted domains, the process-to-object theories remain unfalsifiable.

Others have offered more precise characterisations than Sfard (1991). Cottril et al (1996) emphasised the importance of whether or not the learner could recognise and

construct transformations of the new object. They wrote that a process becomes an object when “the individual becomes aware of the totality of the process, realizes that transformations can act on it, and is able to construct such transformations” (p. 171). In the context of early arithmetic, Gray and Tall (1994) agreed, writing that proceptual thinking included the ability to see symbolism “as the representation of a mental object that may be decomposed, recomposed, and manipulated at a higher level” (p. 125). In a later paper Tall, Thomas, Davis, Gray and Simpson (2000) attempted a direct characterisation of object-based thinking. They asked “what is the object of the encapsulation of a process?”, and answered

[It] is a way of thinking which uses a rich concept image to allow it to be a manipulable entity, in part, by using mental processes and relationships to *do* mathematics (Tall et al, 2000, p. 239).

Essentially Tall et al. suggested that object-based thinking revolves around seeing (what was) a procedure as an object to be manipulated without the need to perform the procedure.

In this paper we situate our investigation into process-to-object theories within the context of early arithmetic (e.g. Davis, 1984; Gray et al., 1999; Kamii, 1985). Specifically we interrogate children’s ability to use the relationship between addition and subtraction to solve simple missing number arithmetic problems. A similar approach has been used by several earlier researchers interested in arithmetic development (e.g. Bryant, Christie, & Rendu, 1999; Rasmussen, Ho, & Bisanz, 2003).

Given the missing number problem  $14 + \square - 11 = 14$ , at least two solution methods are possible. The process-based thinking route would involve explicit calculation of  $14 - 11$ , followed by  $14 - 3$ . An alternative method would be to use the relationship between addition and subtraction to construct the inverse of “-11”, determining that the answer must be “+11”. Based on Davis’s (1984) and Tall et al.’s (2000) characterisation, this method - which relies upon knowledge of the relationship between addition and subtraction, and the construction of the inverse of a subtraction - would appear to use object-based thinking. To perform such an operation the child must treat “-11” as a noun, not a verb: they must not perform the process of -11, but instead must perform a process on -11 by constructing its inverse. Although this higher level process may be straightforward, it does nevertheless involve object-based thinking: “-11” must be treated as a object to be manipulated, not as a process to be performed.

These observations suggest a reasonable way of operationalising the constructs of process- and object-based thinking within the restricted domain of missing number arithmetic problems. If a child is able to quickly and successfully solve missing number problems using an inversion strategy, we can characterise them as exhibiting object-based thinking within this domain. If, however, they are unable to do so, and instead calculate the answer directly, we can characterise them as exhibiting process-based thinking within this domain.



The main goal of the study reported in this paper was to use this operationalisation of process-based and object-based thinking to directly test the predictions of the process-to-object theories: that process-based thinking is a prerequisite to object-based thinking.

**METHOD**

Fifty-nine children participated in the study, which took place in an English state school. There were 26 children from a Year 4 class (mean age 8 years 11 months). The remaining 33 children were from a Year 5 class (mean age 9 years 10 months). Six children declined to attempt a large number of the problems and their data were discarded, thus the data from 53 participants were included in the analysis.

Each child participated individually in two 20-minute sessions. The children completed 48 arithmetic missing number problems, each with four numbers (i.e.  $a+b-c=d$ ). Half of the questions were inverse problems (where  $b=c$  and  $a=d$ ; e.g.  $15+12-12=\square$ ), and these were matched with a control problem that had the same missing number (e.g.  $11+11-7=\square$ ). Half of the problems (both inverse and control) had the operator order plus-first (i.e.  $a+b-b=a$  and  $a+b-c=d$ ) and half had the operator order minus-first (i.e.  $a-b+b=a$  and  $a-b+c=d$ ). In each problem, one of the numbers was missing and the child was asked to supply it. Both class teachers reported that children had no been explicitly taught the short-cut method for solving inversion problems.

Numbers were chosen so that the problems were at the limit of, or just beyond, what could be solved by this age group when using computation. For all of the problems, the first and fourth numbers were between 10 and 30, and the second and third numbers were between 5 and 20. Examples of problems used in the study are given in Table 1. The problems were presented to children on the screen of a laptop. The plus-first problems were presented in one session and the minus-first problems in the other. The order in which the sessions were given was counterbalanced across participants. The problems were presented in a random order for each participant.

Missing number	Inverse		Control	
	Plus-first	Minus-first	Plus-first	Minus-first
Position 1	$\square + 7 - 7 = 13$	$\square - 9 + 9 = 12$	$\square + 14 - 9 = 18$	$\square - 8 + 12 = 16$
Position 2	$13 + \square - 9 = 13$	$15 - \square + 13 = 15$	$15 + \square - 5 = 19$	$18 - \square + 8 = 13$
Position 3	$16 + 14 - \square = 16$	$16 - 12 + \square = 16$	$18 + 9 - \square = 13$	$12 - 8 + \square = 16$
Position 4	$15 + 12 - 12 = \square$	$14 - 5 + 5 = \square$	$11 + 11 - 7 = \square$	$10 - 6 + 10 = \square$

Table 1. Examples of problems used in the study

The task was introduced as a numbers game in which the participants had to work out the missing number. At the beginning of each session there were four familiarisation/practice trials (all control problems). In each trial the problem was

presented on the screen and the experimenter read it aloud twice. When the child responded the experimenter pressed a key and recorded the response. Along with accuracy, the child's response time was recorded (the time between the presentation of the problem and the response key being pressed). The children were given positive encouragement without any specific feedback throughout.

## RESULTS

The main analysis examined individual differences in children's performances using a hierarchical cluster analysis (using Ward's method). Children's accuracy scores on inverse and control problems were entered into a single analysis.

Three clusters were identified which accounted for 81% of the variance in scores. The first cluster identified ( $N=17$ , mean age 9 years 11 months) had high scores on both the inverse (91% correct) and the control (79% correct) problems. The second ( $N=17$ , mean age 9 years 2 months) had low scores on both problems (25% and 15% correct respectively). Crucially, the third cluster ( $N=19$ , mean age 9 years 4 months) showed a high score on the inverse problems (81% correct) but a low score on the control problems (33% correct). Both the first and third clusters were quicker to respond to inverse problems than they were to control problems. No such difference was found for the second cluster. The mean accuracies and response times from the three clusters are summarised in Figure 1.

Two one-way analyses of variance (ANOVA) were conducted to interrogate the differences between the clusters, with cluster membership as a between-groups factor and inverse and control scores as dependent variables. For inverse scores there was a significant effect of group membership,  $F(2,50)=151.72$ ,  $p<0.01$ . Scheffe post-hoc comparison tests (all at  $p < 0.001$ ), revealed that the children in Clusters 1 and 2 were more accurate than the children in Cluster 3; but that there was no significant difference between those in Clusters 1 and 3. For control scores there was again a significant effect of group membership,  $F(2,50)=81.55$ ,  $p<0.001$ , with post-hoc tests (all at  $p < 0.01$ ) revealing that the children in Cluster 1 were more accurate than those in Clusters 2 and 3, and that those in Cluster 3 were more accurate than those in Cluster 2. Similar analyses were conducted with respect to response times (as is typical with RT data, the ANOVA homogeneity of variance assumption was violated; thus these analyses were conducted on log-transformed data). A significant effect of group membership on inverse problems was found,  $F(2,50)=6.43$ ,  $p<0.01$ , with post-hoc tests (all at  $p < 0.05$ ) finding that children in Cluster 2 were slower than those in Clusters 1 and 3, but that there were no significant differences between the transformed response times of children from Clusters 1 and 3. No significant effect was found for control problems,  $F(2,50) = 2.83$ , NS.

To summarise, the children in Clusters 1 and 3 appeared to be able to successfully use the inverse relationship to solve the problems: their mean accuracy rate on inverse problems was high, and their mean response time on inverse problems was lower than their equivalent figure for control problems. In contrast the children in

Cluster 2 appeared to struggle with both types of problem: their accuracies were low and response times high. Crucially, although they were able to successfully use the inverse relationship, the children in Cluster 3 found the control problems (where no inverse relationship shortcut was available) difficult: they solved these problems correctly just one third of the time.

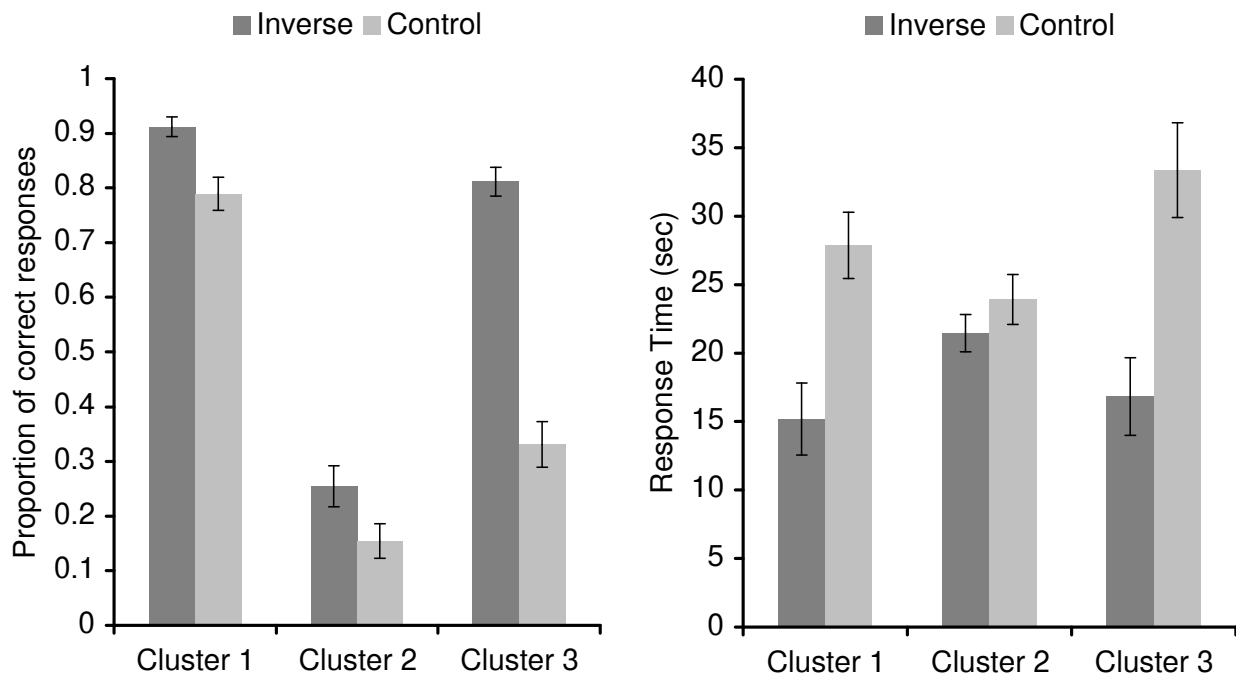

Figure 1. Left: each cluster’s mean proportion of correct responses on the two types of problem. Right: each cluster’s mean response time. Error bars show SEs of the mean.

## DISCUSSION

The behaviour of participants from each of the clusters can be analysed in terms of the process-to-object theories discussed in the introduction to this paper. Cluster 1 appeared to demonstrate both successful object-based thinking and successful process-based thinking. On the inversion problems they showed a high level of accuracy, and were relatively quick. On the control problems - which required an explicit calculation - they were also successful, but were relatively slow (suggesting that they were using the slow process-based method of solving the problems).

Cluster 2, in contrast, demonstrated only unsuccessful process-based thinking. They appeared to be using similar strategies on both the inverse and the control problems, as they had similar (low) accuracy rates and (relatively high) response times.

Cluster 3, however, exhibited a different pattern. They appeared to be using object-based thinking on the inverse problems: their accuracy rate on these problems was high, and their corresponding response times were low, suggesting that they had knowledge of the addition-subtraction inversion relationship and that they could use

it appropriately. However, they did not seem to be able to engage in successful process-based thinking. Their accuracy rates were low on the control problems, and their response times were high. In sum, the children from Cluster 3 seemed able to engage in successful object-based thinking, but did not seem able to engage in successful process-based thinking.

It is notable that we did not find a cluster of children who exclusively used process-based thinking to *successfully* tackle the problems. Such a cluster would be expected to have high accuracy rates, and similar (long) response times to the two types of problem. A cluster of successful process-based thinkers would be predicted by the process-to-object theories, which hypothesise that learners on the verge of encapsulation are highly fluent at process-based thinking.

These results seem to suggest that process-to-object theories may not capture every child's developmental route. The children in Cluster 3 *were* apparently aware of the concept of sum, and could think about it in an object-like way (as a noun, not a verb), but *were not* fluent in performing the sum procedure. If a subset of learners do in fact develop an ability to engage in object-based thinking before process-based thinking, then the assumption that deeper understanding can *only* come through the encapsulation (or reification) of processes into objects seems questionable.

## CONCLUSION

Process-object theories (Davis, 1984; Dienes, 1960; Gray, & Tall, 1994; Piaget, 1985) posit that learners can construct mathematical objects by becoming highly fluent at process-based thinking. Several highly influential theorists have proposed that this is how a deeper understanding of mathematics comes about (Cottrill et al., 1996; Dubinsky, 1991, Sfard, 1991), especially in the domain of arithmetic (Gray et al., 1999; Gray and Tall, 1994). These theories are still highly influential.

In this paper we reported a study which showed that a subset of children apparently follow a different developmental route to that proposed by the process-to-object theorists. They seemed to have developed an ability to engage in object-based thinking about arithmetic despite being unable to perform calculation procedures. Determining whether this finding reflects an object-to-process developmental route, or some more complex developmental interaction between object- and process-based thinking would be a valuable goal for future research.

## References

- Bryant, P., Christie, C., & Rendu, A. (1999). Children's understanding of the relation between addition and subtraction: Inversion, identity and decomposition. *Journal of Experimental Child Psychology*, 74, 194-212.
- Cottrill, J., Dubinsky, E., Nichols, D., Schwingendorf, K., Thomas, K., & Vidakovic, D. (1996). Understanding the limit concept: Beginning with a coordinated process scheme. *Journal of Mathematical Behavior*, 15, 167-192.

- Davis, R. B. (1984). *Learning Mathematics: The Cognitive Science Approach to Mathematics Education*. Norwood, NJ: Ablex.
- Dienes, Z. P. (1960). *Building up Mathematics*. London: Hutchinson.
- Dubinsky, E. (1991). Reflective abstraction in advanced mathematical thinking. In D. O. Tall (Ed.), *Advanced Mathematical Thinking* (pp. 95-126). Dordrecht: Kluwer.
- Dubinsky, E., Weller, K., McDonald, M., & Brown, A. (2005). Some historical issues and paradoxes regarding the concept of infinity: An APOS-based analysis: Part 1. *Educational Studies in Mathematics*, 58, 335-359.
- Gray, E. M., Pitta, D., & Tall, D. O. (1994). Objects, actions, and images: A perspective on early number development. *Journal of Mathematical Behavior*, 18, 401-413.
- Gray, E. M. & Tall, D. O. (1994). Duality, ambiguity and flexibility: A proceptual view of simple arithmetic. *Journal for Research in Mathematics Education*, 25, 115-141.
- Hiebert, J. & Lefevre, P. (1986). Conceptual and procedural knowledge in mathematics: An introductory analysis. In J. Hiebert (Ed.), *Conceptual and Procedural Knowledge: The Case for Mathematics* (pp. 1-28). Hillsdale, NJ: Lawrence Erlbaum.
- Kamii, C. (1985). *Young Children Reinvent Arithmetic*. New York: Teachers College Press.
- Piaget, J. (1985). *The Equilibrium of Cognitive Structures: The Central Problem of Intellectual Development*. Chicago, IL: University of Chicago Press.
- Rasmussen, C., Ho, E., & Bisanz, J. (2003). Use of the mathematical principle of inversion in young children. *Journal of Experimental Child Psychology*, 85, 89-102.
- Sfard, A. (1991). On the dual nature of mathematical conceptions: Reflections on processes and objects as different sides of the same coin. *Educational Studies in Mathematics*, 22, 1-36.
- Skemp, R. (1976). Relational and instrumental understanding. *Mathematics Teaching*, 77, 20-26.
- Tall, D. O. (2007). Developing a theory of mathematical growth. *ZDM*, 39, 145-154.
- Tall, D. O., Thomas, M., Davis, G., Gray, E. M., & Simpson, A. (2000). What is the object of the encapsulation of a process? *Journal of Mathematical Behavior*, 18, 223-241.
- Weber, K. (2005). Students' understanding of trigonometric functions. *Mathematics Education Research Journal*, 17, 91-112.

# LEARNING THE NOTION OF LEARNING GOAL IN AN INITIAL FUNCTIONAL TRAINING PROGRAM

Pedro Gómez, María J. González, and Luis Rico

University of Granada

José L. Lupiáñez

University of Cantabria

*In an initial functional teacher-training program, future teachers are expected to develop their competences for using mathematics education notions in order to analyze a mathematics school concept and use the information emerging from such analysis for the design and implementation of didactic units. In this paper we propose a set of conceptual and methodological tools for exploring and characterizing future teachers learning of those notions. These tools are based on the ideas of meaning, technical use, and practical use of a notion. We exemplify the use of these tools for the case of the notion of learning goal.*

What and how future teachers learn depend on the kind of training they get involved in. If the training follows a functional model (Gómez, et al., 2008), future teachers are expected to develop their teaching competences, where “competence is related to the process of activating resources (knowledge, skills, strategies) in a variety of contexts, namely problematic situations” (Abrantes, 2001, p. 130). In our case, we expect them to learn how to use a set of notions in order to solve didactic problems. Exploring and characterizing future teachers learning implies then describing how future teachers interpret the meaning of those notions, how they use them for analyzing the subject matter, and how they use the resulting information for solving the didactic problems at hand. In what follows, we explain what we mean by initial functional training, introduce the ideas of meaning, technical use and practical use of a mathematics education notion, and present a detailed example of the use of these ideas for describing a group of future teachers’ learning of the notion of learning goal.

## **TRAINING WITH A FUNCTIONAL MODEL**

A functional model of teacher training rests on the idea that the competences of the mathematics teacher can be characterized in terms of what he should be able to do in a specific context of students’ learning. Future teacher training under this approach postulates “a set of tasks, a set of conceptual tools and a subject that, when performing the task using the available tools, put into play and set forth his/her competency in carrying out the processes involved” (Rico, 2007, pp. 49-50). In particular, the planning competence of the mathematics teacher can be characterized from the analysis and description of the tasks, conceptual tools and activities needed to plan a specific mathematics lesson.

Under this functional view, Gómez (2007) has produced a detailed conceptualization of the ideal process by which a teacher designs and implements a mathematical lesson, also attending to the factors conditioning the context. This conceptualization, called didactic analysis, is based on a cyclical procedure that can be used in training

courses for developing future mathematics teachers' planning competence (Gómez, 2006). Four analyses compose the didactical analysis procedure: (a) *subject matter analysis*, as a procedure by which the teacher identifies and organises the multiplicity of meanings of a concept; (b) *cognitive analysis*, in which the teacher describes his hypotheses about how the students can progress in the construction of their knowledge; (c) *instruction analysis*, in which the teacher designs, analyses, and chooses the tasks that will constitute the teaching and learning activities; and (d) *performance analysis*, in which the teacher determines the capacities that the students have developed and the difficulties they may have expressed up to that point. In fact, the planning competence is mainly linked with the three first analysis just described.

The four analysis set up around a set of notions called *curriculum organizers* (Rico, 1997). Representations, errors and learning goals are examples of these notions. Each one of the curriculum organizers captures a face of the complexity of the mathematics curriculum and serves as theoretical support to structure the variety of meanings of a mathematical concept that have to be negotiated in a mathematics classroom. According to the functional view we advocate, curriculum organizers are considered methodological and analytic tools with a didactic purpose. They are the basic pieces that support the future teacher decisions when they are involved in the task planning activity.

## **LEARNING A CURRICULUM ORGANIZER**

From the future teacher learning perspective, we assume that teachers develop their knowledge as a product of action, through the integration, tuning and restructuring of theoretical knowledge to the demands of practical situations and constraints (Bomme & Tillema, 1995, p. 262). When the future teacher takes his first contact with didactic notions-the curriculum organizers-with the perspective of using them in practice, he develops a particular understanding of them that depends on the actions he performs to solve a particular activity. At the same time, the proposed solutions and actions are affected by the developed understanding of the notions. This learning approach is rooted in Vygotsy perspectives and his consideration of instruments as mediators in the individual psychological activity. These instruments undergo complex processes of appropriation-development by users when they are involved in activities. Vygotsky (1982) describes processes that, together with developments of Vérillon and Rabardel (1995), have been recently used to develop the instrumental genesis theory that characterizes learning with artefacts in CAS environments (Guin, Trouche, & Ruthven, 2005). As Trouche (2005, p. 155) has claimed, "the study of instrumented action schemes requires studying, beyond the techniques themselves, their epistemic, heuristic and pragmatic functions". In this paper we will focus on the epistemic, heuristic and pragmatic functions of the curriculum organizers. These three functions characterize the three aspects of the use of a curriculum organizer by a subject: the subject (a) needs some understanding of the curriculum organizer in order (b) to use it for analyzing a mathematical concept, producing useful information that, in turn, (c) can be used possibly in conjunction with others organizer's information, with a

concrete didactic purpose. We denote these three processes *meaning*, *technical use*, and *practical use* of a curriculum organizer, corresponding to its epistemic, heuristic and pragmatic functions.

In the context of preservice teachers' training, the *meaning* (M) of a curriculum organizer is the option that the trainers have taken for the formal meaning of the didactic notion to which it refers, from the multiple meanings that are proposed in the mathematics education literature. Besides, as a tool of the didactic analysis cycle, each curriculum organizer has a heuristic function that we call its *technical use* (TU). It refers to the set of strategies and techniques that, as trainers, we consider necessary for analyzing a secondary school mathematics topic and producing relevant didactic information about it. The information that emerges from the technical use of a curriculum organizer can be used for didactic purposes. This is what we call its *practical use* (PU) and sets up the pragmatic function of the curriculum organizer. It refers to the set of strategies and techniques that, as trainers, we consider necessary for using the information produced with the technical use in other analysis of the didactic analysis procedure or in the design of a didactic unit on the topic at hand. Figure 1 shows a schematic representation of these ideas.

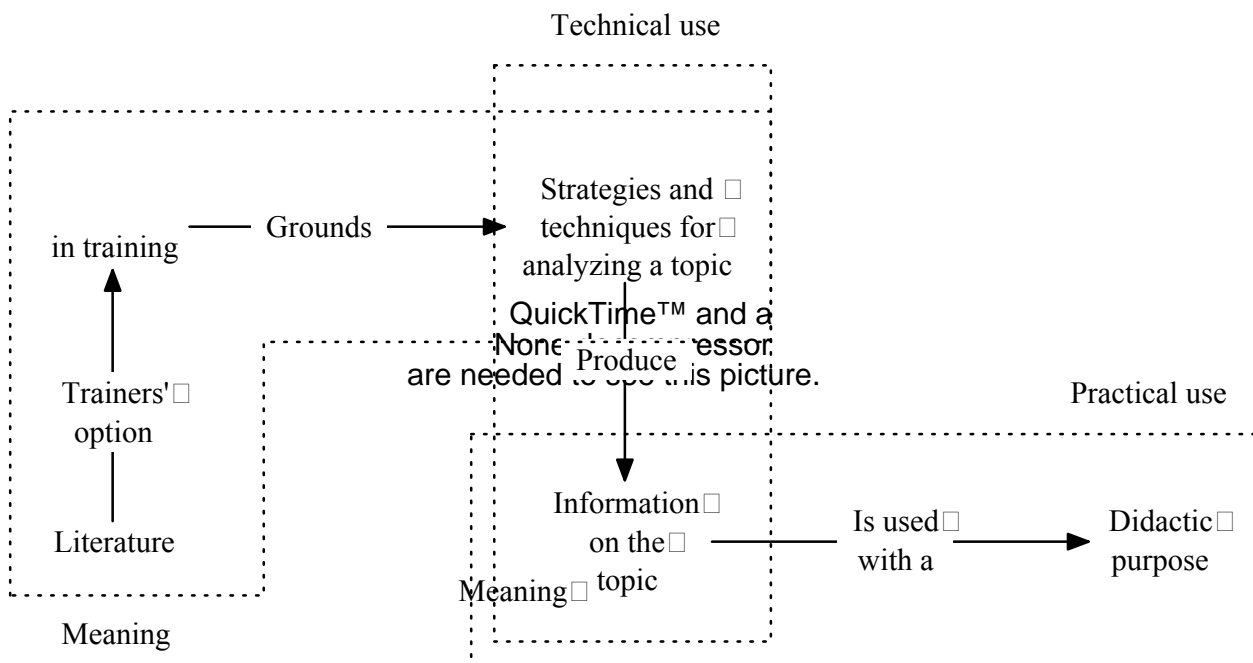

Figure 1. Meaning and uses in teacher training.

We claim that it is possible and relevant to explore and characterize future teachers' learning of curriculum organizers in terms of the ideas of meaning, technical use and practical use. When performing tasks during training, we say that a future teacher *develops the meaning* of a curriculum organizer, if he proposes examples of it, or declares, discusses or reflect on its properties, definition or relationships with other notions. He *develops the technical use* of a curriculum organizer, if he puts it into play in order to analyse a mathematical topic. A future teacher's technical use of a



curriculum organizer is usually based on his interpretation of the meaning of the notion and can involve specific methods or other notions of the didactic analysis procedure. Finally, we consider that a future teacher *develops the practical use* of a curriculum organizer when there is evidence that he uses the information emerging from its technical use for didactic purposes.

### SERIES AND DIAGRAMS

The notions of meaning, technical use and practical use can be used, for instance, for coding and analyzing the protocols of the interaction of a group of future teachers during their training. Episodes along time in the protocols can be identified and coded according to the criteria we proposed above. With this coding procedure, it is possible to organize the sequence of episodes over time that characterizes the future teachers' learning process. This sequence can be depicted graphically in a *series*, as shown in Figure 2 for the learning goal curriculum organizer. The four horizontal zones in Figure 2 under the thick line, show those episodes that have been coded for meaning development (M), technical use (TU), and practical use (PU) of the learning goal notion on other notion A, or practical use of a notion B on the learning goal notion. These other didactic notions (type A or B) have been grouped in the three top horizontal zones over the thick line, depending on whether they belong to subject matter analysis, cognitive analysis or task analysis.

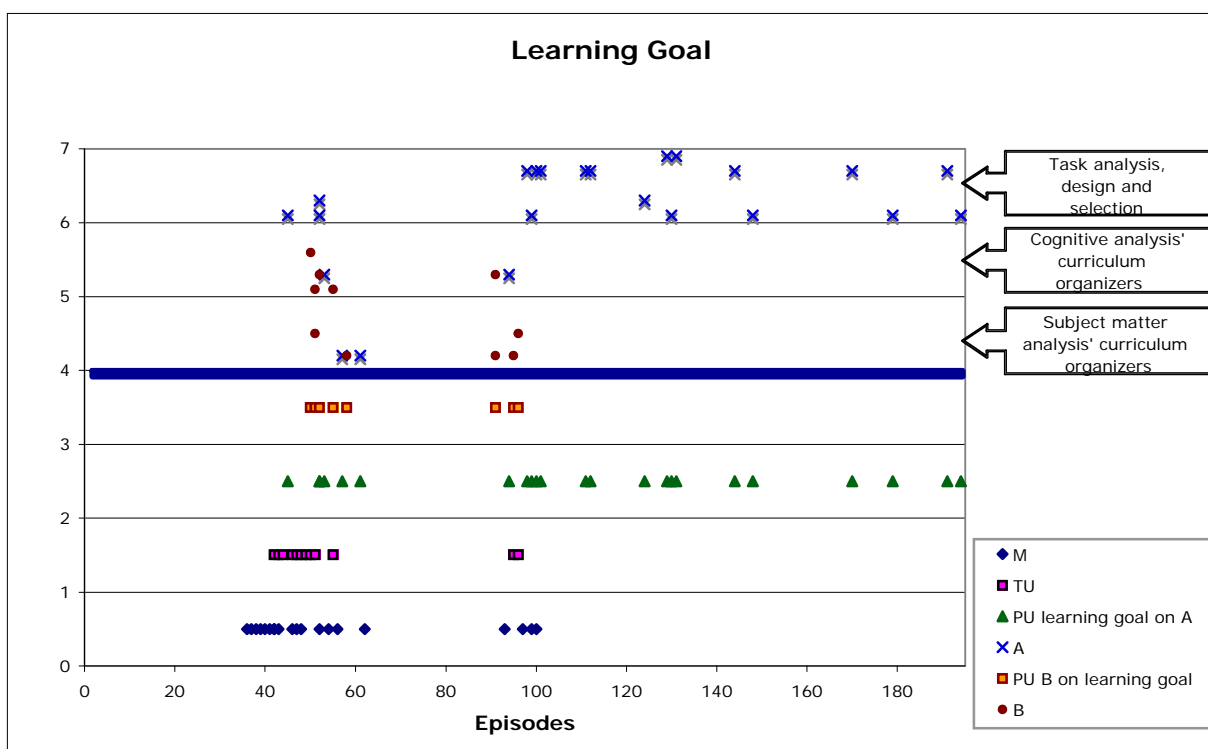

Figure 2. Episodes series for the notion of learning goal.

The series depicts the relationships between the three dimensions (M, TU, PU) of this process and provides information for identifying patterns of use of the curriculum organizer considered. For instance, the analysis of the learning goal series in Figure 2

shows that the meaning and the technical use develop simultaneously: there are two periods in which there is meaning construction at the same time that there is technical use development. One can also see that the information emerging from the technical use is used frequently, mainly in task analysis and selection. This practical use takes place very early in the sequence and keeps developing along it. The diagram of Figure 3 represents this overall learning pattern.



Figure 3. Diagram for the notion of learning goal.

The learning process of a curriculum organizer does not have to follow a unique pattern. Over time, future teachers might follow different patterns in their learning process. We see a curriculum organizer diagram as a representation of the future teachers learning process of that curriculum organizer. It reflects how, in practice and over time, the future teachers transform the curriculum organizer into an instrument. In particular, diagrams show how the curriculum organizers mediate in the process of performing the tasks assigned to them.

### **LEARNING THE NOTION OF LEARNING GOAL**

During the academic year 2006-2007, the University of Cantabria implemented an optional methods' course designed according to the functional model described above. Three female future teachers participated in the course. They were third year mathematics students. They worked as a group and chose the topic "area of plane figures" to perform the didactic analysis on. The methodology used in the course was the same for each curriculum organizer. The trainer started with the presentation of some of the disciplinary meanings of the curriculum organizer. Then, she described with examples how a given secondary school mathematics topic could be analyzed with that curriculum organizer, producing the corresponding information. Then, the group was asked to produce the technical analysis of their topic with that curriculum organizer. Once the information from the different curriculum organizers comprising the didactic analysis was produced and organized, the group was asked to use that information as a whole for designing and justifying a didactical unit for their topic.

The learning goal notion is one of the curriculum organizers involved in the cognitive analysis (together with the notions of error, difficulty, capacity and learning path). The group of future teachers used the information emerging from the subject matter analysis of the topic in order to identify the learning goals of the lesson. Then, they formulated the capacities related to each learning goal and the types of tasks involved. This information enabled them to characterize the corresponding learning paths, to locate students' errors and difficulties and, therefore, to analyze, compare and select those tasks that, in their opinion, could better promote students' learning goals' achievement.

We recorded 35 hours of audio corresponding to the cognitive analysis period of the course. In the transcription of the recordings, we identified 220 episodes, which were coded according to the procedure described above.

A detailed analysis of the episodes series in Figure 2 shows three different periods. In the first one, between episodes 35 and 60, there are passages of different types. On the one hand, there is an effort in meaning construction. Most of these episodes are simultaneous with the development of technical use. This technical use seems to produce a later practical use mainly in task analysis and selection. In this period, the notions from cognitive analysis and subject matter analysis are used in the technical use of the notion of learning goal. The following is episode 48 of this period:

Future teacher: Learning goal, that is, for instance, let us see if we can say something like: “strategy development”. We could start a learning goal like that, couldn’t we? OK, “strategy development for calculating unknown magnitudes”... And there, we could finish the learning goal, couldn’t we? We could extend it, that is what I was saying, or include more things in the learning goal.

In this episode we recognize how the future teacher is constructing the meaning of the notion of learning goal. She is not sure whether a statement is a learning goal or not and whether a statement can be regarded as a complete learning goal (“couldn’t we?”). This construction of meaning is not done from a formal definition of the notion. It is done through its technical use: the future teacher proposes two versions of a learning goal for the topic at hand and looks for confirmation of her conjectures from the trainer and her fellow future teachers.

In the second period, from episodes 91 to 100, the situation is similar to the first period. Nevertheless, there is less technical use development. Meaning and technical use of this notion do not appear to be simultaneous.

Finally, the third period is concerned with the notion’s practical use, mainly for task analysis and selection. The following episode (108) shows the practical use of the notion of learning goal.

Future teacher 1: For our learning goal, the goat problem is perfect. All the items, except one. There is only one question that refers to other types of learning goals. The others are all about our capacities.

Future teacher 2: What are we looking for? Only one problem for each learning goal? Because I like the perimeter problem.

Future teacher 1: The perimeter problem is a good one, but it does not refer at all to this learning goal.

Future teacher 2: OK, OK.

In this episode, we see how the group of future teachers makes a practical use of the notions of learning goal, capacity and learning path with the purpose of selecting a task: they assess whether the sequence of capacities that are put into play by the task correspond to the given learning goal. They recognize that the goat problem puts into play the capacities they are interested in, whereas the perimeter problem does not. In

the same episode, they develop the meaning of the learning goal curriculum organizer: they ask themselves how many tasks were necessary in order to assess it.

Table 1 shows the diagrams representing the patterns identified in these three periods. They give a more detailed explanation of the patterns depicted in Figure 2.

Periods			
1	2	3	
CandSM: Cognitive and subject matter analysis; SM: Subject matter analysis; TAandS: Task analysis and selection			

Table 1. Learning diagrams (periods)

## DISCUSSION

One could expect that the process of learning a curriculum organizer should correspond to the sequence followed in the course instruction: first to construct the meaning of the notion, then interpret this notion in practice in order to develop strategies for analysing a topic with it (technical use), and finally use the information emerging from the technical use for other analysis or the design of a didactic unit. The diagram  $M \rightarrow TU \rightarrow PU$  can represent this sequence. But this was not exactly the case for the notion of learning goal that we have presented. In this case, meaning and technical use were developed interactively in the first period. Future teachers had an informal meaning of the notion of learning goal. When, in the technical use phase, they tried to identify learning goals of a lesson, they realized that such informal meaning was not enough, and was not necessarily the same as the meaning proposed by the instruction. They progressed in the meaning construction as a consequence of the requirements of the technical use of the notion. In the second period, technical use did not appear directly linked to meaning development. Now, future teachers made a practical use of subject matter analysis curriculum organizers to produce learning goals of the lesson and use them in practice. This method constituted their particular strategy to produce and use didactic information. In the third period, the absence of arrows in the diagram shows that future teachers did not made explicit references to meaning nor technical use while they performed the notion's practical use.

We have found in some preliminary explorations with other curriculum organizers of the cognitive analysis, that preservice teachers do in fact enact different sequences for different curriculum organizers (González and Gómez, Forthcoming). In some cases, they do not have an informal meaning of the curriculum organizer, and they have to construct it before putting it into play. In other cases, they do not see the need for checking their informal meaning against the meaning proposed by the trainers. We

have not yet explored if there are characteristics of particular curriculum organizers that promote some specific patterns, or under what circumstances some patterns are more frequent than others.

We claim that answering in detail the questions of what patterns appear and why, can help us, as researchers, understand how learning takes place in a methods course based on a functional perspective of teacher training and learning. It can also help us, as trainers, in assessing the design and development of our training programs.

## References

- Abrantes, P. (2001). Mathematical competence for all: Options, implications and obstacles. *Educational Studies in Mathematics*, 47(2), 125-143.
- Gómez, P. (2006). Análisis didáctico en la formación inicial de profesores de matemáticas de secundaria. In P. Bolea, M. J. González, & M. Moreno (Eds.), *X Simposio de la Sociedad Española de Investigación en Educación Matemática* (pp. 15-35). Huesca: Instituto de Estudios Aragoneses.
- Gómez, P. (2007). *Desarrollo del Conocimiento Didáctico en un Plan de Formación de Profesores de Matemáticas de Secundaria*. Granada: Departamento de Didáctica de la Matemática de la Universidad de Granada.
- Gómez, P., González, M. J., Rico, L., Gil, F., Lupiáñez, J. L., Marín, A., Moreno, M. F., & Romero, I. (2008). *Future Secondary Mathematics Teachers Training from a Functional Perspective*. Paper submitted to Topic Study Group 29 of ICME 11.
- González, M. J. & Gómez, P. (Forthcoming). *Meaning and Uses in Initial Teacher Training*.
- Guin, D., Trouche, L., & Ruthven, K. (2005) (Eds.). *The Didactical Challenge of Symbolic Calculators. Turning a computational device into a mathematical instrument*. New York: Springer.
- Rico, L. (1997). Los organizadores del currículo de matemáticas. In L. Rico (Ed.), *La Educación Matemática en la Enseñanza Secundaria* (pp. 39-59). Barcelona: ice - Horsori.
- Rico, L. (2007). La competencia matemática en PISA. *PNA*, 1(2), 47-66.
- Trouche, L. (2005). An Instrumental Approach to Mathematics Learning in Symbolic Calculator Environments. In D. Guin, K. Ruthven, & L. Trouche (Eds.), *The Didactical Challenge of Symbolic Calculators* (pp. 137-162). Dordrecht: Springer.
- Verillon P., & Rabardel, P. (1995). Cognition and artifacts: A contribution to the study of thought in relation to instrumented activity. *European Journal of Psychology of Education*, 10(1), 77-101.
- Vygotsky, L. S. (1982). El método instrumental en psicología. In L. S. Vygotsky (Ed.), *Obras escogidas* (Vol. 1, pp. 65-70). Madrid: Ministerio de Educación y Ciencia.

# THE INTRODUCTION OF THE GRAPHIC REPRESENTATION OF FUNCTIONS THROUGH THE CONCEPT OF CO-VARIATION AND SPONTANEOUS REPRESENTATIONS. A CASE STUDY

Alejandro S. González-Martín

Fernando Hitt

Christian Morasse

Université de Montréal

Université du Québec à  
Montréal

Collège de Montréal

*Our research project deals with representations. Since 2005 we have addressed the problem of constructing a mathematical concept, that of function, taking into consideration the spontaneous representations students produce when solving a mathematical situation. Our experimentation was conducted with two groups of students in grade 9 from Québec. In this document are two questions: “How do the students’ representations evolve when solving a mathematical situation?” And, “How does this evolution take place when the students work in teams in a collaborative learning, scientific debate and self-reflection environment?” These questions are addressed by analysing one particular student working in a team and contrasting their results with the results obtained after a debate with other teams.*

## INTRODUCTION

In 2005, a large research project began with the goal of studying spontaneous representations used by the students in the construction of concepts in grade 8. Taking into consideration the results of this previous project (see Hitt, 2006; Hitt & Passaro, 2007), we started a new research project in 2007, taking into account the new secondary program for grades 9 to 11 in Québec (MELS, 2007). In this new program, the process of modeling is taught in grade 9 and is the concept of function at the heart of the syllabus.

Carlson (2002) stated that to develop the concept of function, it is required to first develop the concept of co-variation. Our 2005 research project agreed with this thought process, and our aim is to elaborate this point of view further in this new research project.

Our revision of literature (see Hitt, González-Martín, & Morasse, in process) led us to wonder whether the use of spontaneous representations and of manipulative materials, working as a bridge between the students’ informal knowledge and the standard graphic representations used in teaching, could help the students grasp the concept of co-variation. To tackle this question, we designed activities to help the students make a transition from their representations for the notion of co-variation to the standard graphic representation. Through a single case study, we analyse one of the activities we designed and the actions that it prompted in one particular student who worked in a team, and to decide whether this activity was useful to help this student acquire the necessary knowledge of the standard graphical representation of functions to represent situations of co-variation. We also analyse how this activity promoted a way of thinking to construct the concept of co-variation.

## BACKGROUND

Our approach takes into consideration the role of representations. A mathematical concept is constructed by forming an articulation among different representations of that concept. When we talk of a concept constructed by a student in a socio-cultural approach, we are assuming that the spontaneous representations used by the student are important, and that they are going to evolve to the institutional ones used by the teacher or presented in textbooks. Following this approach, we elaborated a methodology named ACODESA, which takes into account collaborative learning, scientific debate and self-reflection (see Hitt, 2007).

## METHODOLOGY

The activities were developed in two groups of students in grade 9 (24 students in one group and 36 in the other) during the months of October and November, 2007.

We created five activities that work together to form a sequence which introduces the concept of co-variation as a prelude to the concept of function. At the same time these activities aim to institutionalise the standard graphical representation of functions. In Hitt, González-Martín, & Morasse (in process) there are further details of these activities. The five activities are: “The Photographer,” “The Hiker,” “The Jacuzzi,” “The Squares in Movement,” and “The Shades.” The first of these activities introduces the idea of co-variation and asks the students to represent the given situation without any constraint. In the second activity, “The Hiker,” we tried to help the students make the transition from their spontaneous representations for the co-variation to the standard graphical representation of functions specifically by the use of manipulative material.

This paper focuses on the activity, “The Hiker” and we will analyze its effectiveness to promote particular actions on the part of students to pass from a spontaneous representation for the concept of co-variation to a standard graphical representation. “The Hiker” starts with the following text on the second page:

P2	A hiker undertakes a long excursion in a forest. He follows a path which allows him to return to his starting point at the end of the excursion. During the walk, the track never passes the same place twice, in essence, completing only one circuit. An aid station is located inside the area delimited by the track. A flagpole makes it possible for the hiker to locate the site of the aid station wherever he is on the track. Trace a track of your choice and place the aid station inside the track.
P3	The distance between the hiker and the aid station varies according to the location of the hiker on the track. Describe this variation.
P4	Find a new way to present the phenomenon described on page 3, excluding the drawing of the track appearing there.

The question on page 3 asks the students to use their spontaneous representations to model the situation and to start understanding how the two magnitudes (distance walked and distance to the aid station) vary. The question on page 4 is one that

pushes the students to a process of abstraction, eventually leading to the standard graphic representation of a function.

Before working in teams, a general discussion was required in order to choose the same path for the whole class. A squared-shaped path, with the aid station in the middle, was chosen by consensus. The activity then continued:

P5	By using the answer to the preceding question (page fourth), describe in words how the distance between the hiker and the aid station varies depending on the place where the hiker is when he walks on the track.
----	--

In total we had 6 pages for individual work and 12 pages for the team version. Due to the length of this paper, we will only discuss the actions of one particular student to the preceding questions. But before doing so, we would like to stress that we wanted the students to discuss their spontaneous representations and to reject parts of them during their team discussions. We also wanted some evolution in their representations in order to produce a graph as a result of a debate.

## DATA ANALYSIS

As we said before, the entire class chose a square-shaped path with the aid station in the center. The team's first approach began with the proposition of a student who we will call Leyla (fictitious name chosen to preserve the student's identity). She drew the distances from specific points of the path to the center: the corners, the middle points of each side and the quarters of each side, as well (Figure 1). This gave her an idea of the variation of the distance.

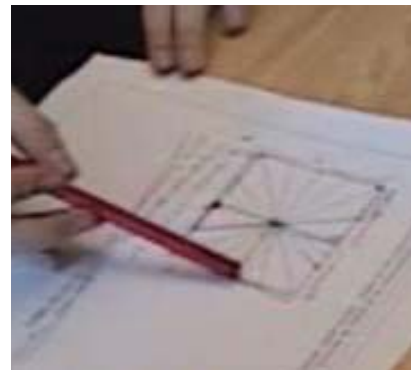

Figure 1.

While doing the work with her team and in order to answer the question on page 3, she stated that there were many distances that were the same and also that distances from the corners to the center were the largest ones. This showed her understanding of the situation.

However, as we had predicted, the students' first approach was still too attached to their drawing. The students in the team attempted to grasp how to describe the variation of the distance. At that moment, they were focusing on how to measure the distances over the border of the square (“*this is a half of a side, so a half of a quarter...*”).

After a few minutes of discussion regarding this first approach, the teacher intervened to present another one of the main features of our methodology: the use of manipulative material. The teacher invited the students to use wire, thread and sticks if they wanted to, to better represent the situation. The first student to use these materials was Leyla. But after using them for some time, she responded with, “*I don't understand the question.*”

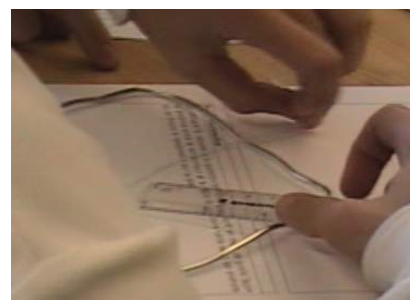

Figure 2.



The teacher explained that it was a matter of describing how the distance between the hiker and the aid station varied according to the hiker's position on the path, trying to be detached of the physical path so that this description could be useful for other kinds of paths. This hint gave her and her team the idea of using a square-shaped wire to denote the path and to measure the distances to the center using a ruler and a thread (Figure 2). By the end of the first session, she and her team were able to state that while the hiker walks, the distance changes and it is maximum when he is at the corners and that the distance diminishes when he walks towards the middle point of each side.

At the beginning of the second session, the team repeated their discovery: "*There's a decrease of the distance when he walks to the middle-point of the side, and when he moves towards the corners, the distance increases.*" One of her teammates added, "*We have to find words to explain it.*" Leyla added that what happens on one side happens again on the other sides, because it was a square. At this point, to help them start understanding the question on page 4, the teacher asked them to try to *abandon* the initial drawing and to find a new way to represent the phenomenon. Leyla added, "*Actually, there's like an alternation: small, big, small, big, ...*" (see Figure 1 again). The teacher prompted them to try to represent the same information without using the drawing of the square. At that moment, seeing that the team was stuck, the teacher suggested to use the wire and reminded them that the wire was flexible.

Immediately, Leyla took the wire, unfolded it, making sure to keep her finger on the point where the aid station originally was to mark it (Figure 3). When the teacher asked, "*Is it the same path?*" some members of the team answered, "*no,*" but when he reformulated the question, "*It is not the same shape, but is it the same track?*" they all answered that it was.

With the track completely unfolded, Leyla had to face one obstacle prompted by their attachment to the initial drawing. She said that once the track unfolded, the distances varied and that the distance from the corner, which was on the edge of the wire, to the aid station now was longer (Figure 4). At that moment she moved back and said that she could not understand why the use of the wire was necessary. The teacher answered that the idea was to abandon the shape of the path and just to focus on the distances. Her answer was again that it did not work: once the track unfolded, the distances to the aid station changed.

Here we can see that she was focusing on just one

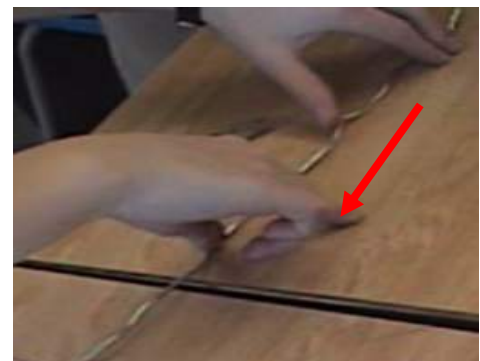

Figure 3.

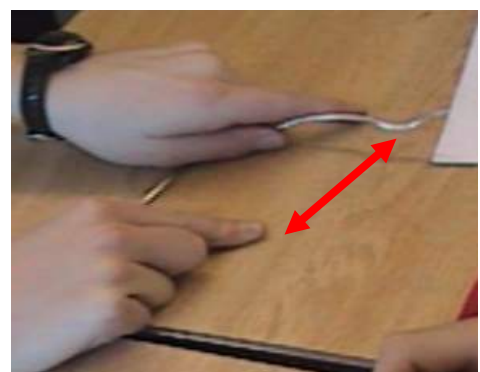

Figure 4.

variable: the distance on the track. She folded the wire and could calculate the distances to the aid station (center of the square). But when she unfolded the wire, she calculated again the distances to the same point. At that point, she could not conceive of unfolding the track with both variables fixed (distance on the track and distance to the aid station), that is, the co-variation of both magnitudes.

The teacher asked her, “*Am I really interested in the aid station?*” and one of Leyla’s teammates answered, “*No. You are interested in the distance between the hiker and the aid station.*” She could not grasp the concept and continued to fixate on the aid station coming to the same conclusion: when the wire was folded, the distance from one corner to that aid station was 7cm and when the wire was unfolded, the distance from that same corner to the aid station was 20cm (Figure 5).

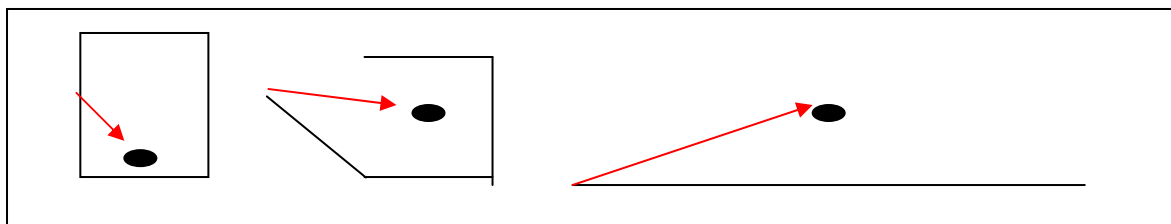

Figure 5.

At that moment, the team received a suggestion to use the thread instead of the ruler to measure the distance. The teacher asked Leyla to cut a 7 cm piece of thread and at that moment she exclaimed, “*AAaah!*” The teacher added: “*Employ this [the drawing of the square] and this [the wire and the thread] at the same time*” and left. Some minutes later, Leyla had already cut some pieces of thread and had ordered them by size: “*This one is big, this one is small...*” When asked what each piece represented, the team answered, “*They represent the length between the side of the square and the center.*” Leyla and her teammates added that they had an idea: they wanted to paste the pieces of thread to the wire. Leyla added: “*We are going to rebuild the square and when we unfold it, they [the pieces of thread fixed to the border] are going to stay.*” But when she recreated the square track, the thread bent and did not remain rigid. The teacher brought some sticks over and suggested to replace the thread with the sticks.

After further discussion with her teammates and working on fixing the sticks, Leyla succeeded at creating a square with the sticks pointing to the center (Figure 6) and explained, “*This [showing one big stick] is the distance between the corner and the center. This [showing one small stick] is the distance to the middle points. Here [putting both sticks aside] we put one next to the other and we can see that there is one that is bigger. What this shows is that there is an alternation between big and small, big and small, ...*”

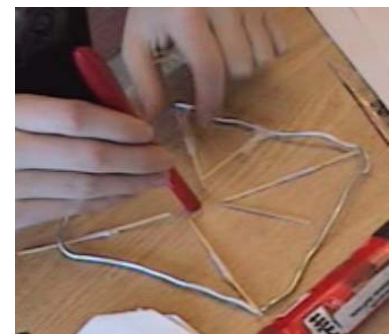

Figure 6.

One of Leyla's teammates wrote the following statement, showing an understanding of the co-variance, "*The more the hiker walks towards the middle point of one side on his path, the distance between him and the aid station decreases, but as soon as he passes the middle point and approaches the turning point (corner) the distance increases.*" Once the track was unfolded (Figure 7) they were able to explain their understanding of the situation and made reference to the length of the different sticks.



Figure 7.

In our opinion, Leyla and her teammates went beyond the initial difficulties and grasped an understanding of the co-variation of the two magnitudes in this situation. In addition to the latter, their unfolded track is a bridge between their first spontaneous representation and the standard graphic representation of a function. The wire represents the axis of the abscises (and the marks on the track) and the sticks represent the ordinates (or distances between the hiker and the aid station). Indeed, when the teacher asked them, "*Once unfolded, is it familiar? [...] This idea that there is the line with the other distances...*", one teammate answered, "*It looks like the graph of proportions [...] in the Cartesian plane...*" and identified all the elements, which verifies our interpretation. Finally, they were able to create a system of coordinate axes to represent the situation (Figure 8). The final result of this team was to link the points by straight lines.

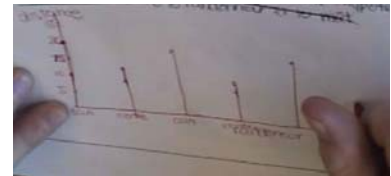

Figure 8.

In the process of the debate, another team rejected the idea of joining the points by straight lines and instead suggested a smooth curve. Another team rejected the two propositions and finally proposed the right curve for this situation. Leyla was astonished by the suggested graphs and decided to consider more intermediate points on the path, to measure their distances to the center of the square, and to sketch the corresponding points that gave her the shape of the graph (Figure 9) to convince herself and her teammates about the result. The students conducted a real scientific debate!

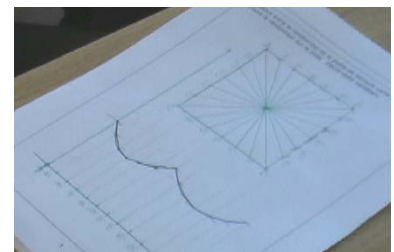

Figure 9.

At the end of the discussion, and using our methodology, we collected all work made by the students and gave them the same situation to solve individually (as a homework assignment). The students were asked to reconstruct a solution using the ideas emerged in the work in teams and during the debate with the whole group. Again, we can find in Leyla's homework that she integrated the ideas that emerged in the debate to show a stable understanding. There was a socio-cultural construction of a concept of co-variation and this section has showed Leyla's performance and her interactions with her teammates, the teacher and the rest of her classmates in a debate.

## CONCLUSIONS

The analysis of Leyla's actions allows us to see that she has followed all the steps foreseen in the design of the activity. From an initial and spontaneous representation of the situation, in which both the path and the aid station are still very present, to an abstract representation in which only the distance walked and the distance to a given point matter. In the process of passing from one representation to the other, the following have been crucial: the exchanges with her team, the use of manipulative material and the confrontation with the results obtained by the other teams.

The activity offers a stimulating problem-situation to the students, who engage in its resolution. Also, the fact that there is some freedom (to choose the path) allows the students to appropriate the context. In addition to the latter, the students can start using spontaneous representations to figure out the phenomenon. The initial individual work made by the students promotes a preliminary reflection that is rebuilt by the work in teams. The questions asked on pages 4 and 5, together with the interactions with the members of the team and the exchanges with the teacher, promoted a process of abstraction producing a detachment from the shape of the path and the situation of the aid station. At this point, we think that the use of manipulative material has proven to be very important, since it allowed the students to grasp the situation and by just unfolding the wire, to pass from a representation of a physical situation to a new representation that is near to the institutional one. That is, the material allowed the students to rethink their spontaneous representations, and to consider another type of representations to communicate their ideas to others. As Radford (1999) quoted from Vygotsky and Luria's work (1994, p. 112): "The practical use of tools and the symbolic forms of activity [...] form a complex psychological entity...".

Karsenti (2003) has written about what adults remember from their high school mathematics, warning us about our methods of teaching and learning. Under our approach of collaborative learning, scientific debate and self-reflection (ACODESA) we think we can promote a better retention of mathematical concepts than those constructed in a classical approach of teaching. The integration of this activity in a larger sequence has already been achieved and we are now analysing the effects of the entire sequence, which will become the source of a better understanding about spontaneous representations. The results of this experience are promising and the construction of new activities based on the use of manipulative materials to introduce the concept of function and the process of modelling seem to be a very fruitful and important task to improve our students' understanding of mathematical concepts.

## References

- Carlson, M. (2002). Physical enactment: a powerful representational tool for understanding the nature of covarying relationships. In F. Hitt (Ed.), *Representations and Mathematics Visualization* (pp. 63-77), Special issue of PME-NA and Cinvestav-IPN.

- Hitt, F. (2006). Students' functional representations and conceptions in the construction of mathematical concepts. An example: The concept of limit. *Annales de Didactique et de Sciences Cognitives*, 11, 253-268.
- Hitt, F. (2007). Utilisation de calculatrices symboliques dans le cadre d'une méthode d'apprentissage collaboratif, de débat scientifique et d'auto-réflexion. In M. Baron, D. Guin, & L. Trouche (Eds.), *Environnements Informatisés et Ressources Numériques pour L'apprentissage. Conception et Usages, Regards Croisés* (pp. 65-88), Éditorial Hermes.
- Hitt, F., González-Martín, A. S., & Morasse, C. (in process). Visualisation and students' functional representations in the construction of mathematical concepts. An example: the concept of co-variation as a prelude to the concept of function. Submitted to *Topic Study Group 12, ICME-11*, Monterrey (Mexico).
- Hitt, F. & Passaro, V. (2007). De la resolution de problèmes à la résolution de situations problèmes : le rôle des représentations spontanées. In *Actes de la 59 Commission Internationale pour l'Étude et l'Amélioration de l'Enseignement des Mathématiques (CIEAEM59)*, Dobogókö (Hungary), 117-123.
- Karsenty, R. (2003). What do adults remember from their high school mathematics ? The case of linear functions. *Educational Studies in Mathematics*, 51, 117-144.
- Ministère de l'Éducation du Loisir et du Sport (MELS) (2007). Programme de Formation, Deuxième Cycle du Secondaire. <http://www.mels.gouv.qc.ca/DGFJ/dp /menusec.htm>.
- Radford, L. (1999). On culture and mind : A post-Vygotskian semiotic perspective. With an example from Greek mathematical thought. Pre-print 2, Université Laurentienne. Ontario, Canada.
- Vygotsky, L. & Luria, A. (1994). Tool and symbol in child development. In R. van der Veer & J. Valsiner (Eds.), *The Vygotsky Reader*: 99-174. Oxford: Blackwell Publishers.

# THE NUMBER LINE: AMBIGUITY AND INTERPRETATION

Eddie Gray

University of Warwick

Maria Doritou

University of Nicosia

*The number line, a sophisticated mathematical representation characterised as a metaphor of the number system, may be seen as an essential classroom aid to support the needs of pedagogy and learning. This paper associates children's use and understanding of the number line with their teacher's perceptions. In doing so, it presents an illustrative example of the presentation and reception of the use of a representation within the classroom. Ambiguous association of the number line with a number track appears to focus children's understanding on a perceptual representation used as calculating aid. This leads to conceptual difficulties in the knowledge reconstruction needed to deal with larger numbers and fractions, limited understanding of its use as a metaphor and its final rejection as procedural support.*

## INTRODUCTION

Investigation into the use of representations for the teaching and learning of mathematics suggest that though each individual constructs a meaning from the representation based upon its unique conceptual structure, these meanings may be at variance to those intended (Cobb, Yackel, & Wood, 1992). As a consequence, though children may learn how to use a representation, they may not conceptualise the mathematical meaning behind it (Dufour-Janvier, Bednarz, & Belanger, 1987).

The concerns and issues associated with pedagogic representations in general apply equally to the number line, particularly in the way it is presented in schools and conceptualised by children even though it can be used as a tool to support the development of arithmetical operations (Klein, Beishuizen, & Treffers, 1998).

This paper investigates the teaching and learning associated with the number line within one English school that was following the recommended curriculum - in this case the *National Curriculum for Mathematics* (NC) (DES, 1991) and its associated support *The National Numeracy Strategy* (NNS) (DfEE, 1999). Though an abstract and sophisticated representation evolving from plane geometry, there appears to be no explanation of its meaning within the documents recommended to English schools. Furthermore, the frequent appearance of the number line within these documents raise an important issue - does the emphasis on the use of the number line as a tool rather than as a representation of sophisticated ideas, encourage a procedural rather than a conceptual way of teaching and learning that contributes towards children's difficulties in understanding our number system?

Responding to this question, this paper examines children's perception, understanding and use of the number line within the context of teachers' understanding and the way it is used within the classroom.



## THEORETICAL FRAMEWORK

In the context of the number line, Lakoff, & Núñez (2000) refer to a “points on a line metaphor”, where the points correspond to real numbers. Herbst (1997) refers to the “number line metaphor” of the number system and, whilst emphasising its “intuitive completeness” (p. 40), defines its construction in the following way:

one marks a point 0 and chooses a segment  $u$  as a unit. The segment is translated consecutively from 0. To each point of division one matches sequentially a natural number (Herbst, 1997; p. 36).

It is the one-to-one correspondence between numerical statements and number-line figures that suggests the use of the number line as a pedagogical tool. However, using a metaphor to teach, can lead to a “learning paradox” (Cobb et al. 1992) — its structure needs to be understood by both the teacher and the pupils. Without such understanding, perceptual and conceptual factors may lead to problems in the use of the number line, particularly when it involves the reconstruction and consequent extension of the concept of number from whole number to fraction and/or decimal (Lesh, Behr, & Post, 1987).

Within the material presented to English schools, the number line is recommended as a suitable model for the hierarchical development of the number system from Reception (median age 5 years 6 months) through to Year 6 (median age 11 years 6 months). Associated with the general intention of increasing levels of high achievement, the number line is considered to be an appropriate representation for developing knowledge of the number system. Examples with illustrations reflect this intention through the development of counting, ordering and pinpointing skills and the performance of arithmetic operations and the introduction to fractions and decimals. A recent version of the NNS (DfES, 2006) reiterates these but it generally introduces operational concepts and the extension of the number system to include fractions approximately one year earlier than the 1999 document.

However, within the documentation the number line appears not only as an alternative version of the number track, but also in a fragmented “micro” form to emphasise particular features of the number system such as whole number or fraction in such a way that each is frequently treated as a discrete model. A consequence is that within both versions of the NNS (DfEE, 1999; DfES 2006) there is a tendency to emphasise procedural application of the number line as a tool with little if any consideration given to its conceptual structure. Thus, though the number line is not defined, it is seen as “... a means of showing how the process of counting forward and then back works” (QCA, 1999; p. 31).

The absence of an explicit reference to conceptual knowledge relating the form and use of the number line leads to some ambiguity between it and the number track (and on some occasions the hundred square) even though Skemp (1989) had clarified the perceptual and structural differences between the two:

... differences between a number track and a number line are appreciable, and not immediately obvious. The number track is physical, though we may represent it by a

diagram. The number line is conceptual - it is a mental object, though we often use diagrams to help us think about it. The number track is finite, whereas the number line is infinite. However far we extend a physical track it has to end somewhere. But in our thoughts, we can think of a number line as going on and on to infinity (pp. 139-141).

It would therefore seem incumbent upon teachers to distinguish between these two terms to avoid the development of misunderstanding and confusion between the two concepts by their pupils.

## **METHOD**

The results presented in this paper form part of a broader study on the use and understanding of the number line representation within mathematics classrooms (Doritou, 2006). Carried out during 2003 and 2004, the school chosen for the case study was well ordered, but was considered to achieve below the national average compared to other schools. It may be seen as an example of the type of school the NNS was designed for in its attempt to encourage a rise in level of achievement. Indeed, this may have had a desired effect. In 2004 following an inspection by OfSTED, mathematics within the school was given the overall assessment of 'Good', signifying that teacher's good subject knowledge was associated with a considerable improvement in teaching and mathematical development.

Viewing things from a constructivist perspective, and therefore largely qualitative in nature, the report is drawn from the case study of an individual school and upon elements of action research to consider the underlying understanding of the representation by teachers and the way it is used and understood by children. A further element has an ethnographic flavour in that there is an attempt to interpret the actions and construal of the children in terms of the indications of the teachers. Restriction of the size of the report inevitable mean that illustrative examples are drawn from interviews with 22 children- median ages ranging from 6.5 to 10.5 (four from each of the year groups Y2, Y3 and Y4, and five from each of the years Y5 and Y6) - drawn from a larger sample of 90 children and chosen to represent a cross section of achievement based upon actual and predicted achievement in the national Standard Attainment Tasks (SATs), mediated by each class teacher's personal assessment. The teachers were those who taught the children mathematics.

## **RESULTS**

To establish whether the teachers recognised the number line as a metaphor of the number system, the teachers were asked to talk about the way they used a number line in their lessons. In general, they appeared to associate it more with actions rather than with its unique property to represent number system continuity:

When doing number sequences circle the numbers and look at the steps we're taking each time. If it's addition, look at it with jumps. Subtraction counting back. (TY2)

Use it for addition, subtraction mainly. Maybe some multiplication as repeated addition... For fractions, labelling the ends zero and one or zero and two. (TY3)



The sense derived from the interviews was that the teachers were describing a specific number line, but often this specificity was limited to the more obvious perceptual characteristics rather than conceptual aspects of the line:

I have got the number line, which is really useful, but because it's so long, it is quite hard... It's at least two metres [*a number line on laminated card under the board*]. I do refer to it quite a lot, but I do use the number square as well. I do try and encourage the children that it's the same. (TY2)

It's a good representation for them to be actually able to see it! It has it (numbers) all in order and they can see it! (TY5)

In doing this, essential features were often omitted and this was frequently reflected in the children's perception of the number line. When children were asked to indicate what a number line was, over 75% of them, largely from within Years 2, 3 and 4 but with single respondents from Years 5 and 6, gave responses that suggested either a particular number line embodiment:

It's a big row of numbers; just straight... it's going that way [*towards the right*] instead of that [*top to bottom*] way. Sometimes you can get number squares. It's the same as a number line, but it's a line. I'll go and get one... They tell you how to count. [*They are made of*] wood. Sometimes wood. (Child 2.2)

A number line is a line that has numbers on. (Child 4.2)

or were associated with memory of activities observed or carried out with the line:

Numbers... Counting back and forth. (Child 3.3)

Just a line that you count numbers on ... you put numbers on and you had to take things away and add things and times and that. (Child 5.5)

What was a surprise was that in essence there was little qualitative difference between the 'definitions' provided by children of different year groups. Only one child provided a response that differed qualitatively from the more common responses. Though it contained description and was associated with actions, it also included reference to decimals as well as whole numbers:

A number line is just a line that put one number like sixty-seven [*Draws line and puts 67 at left end*] and one number say like seventy [*marks right end*], and the numbers that go in between. [*marks the numbers 68, 69*] ... you have decimals like sixty-seven point five, ... sixty-eight point five and so on... [it] helps you work out the take-aways or additions basically.... (Child 6.2)

This child's understanding of the number line is a blend of ideas, indicating signs of appreciating the conceptual underpinning of the number system by the number line:

That's the quarter there [*points at 0.25*], that's the half [*points at 0.5*] and that's three quarters [*points at 0.75*]. (Child 6.2)

Neither during the observed teaching nor during interviews with other children was the potential richness expressed by this child apparent. The teachers did not clarify the nature of the number line to their children as they encouraged its use in the

context of procedures. However, teachers of younger children suggested strong similarities between the number track (together with the segmented track that is the hundred square) - always containing whole numbers - and the number line, making little, if any, distinction between these terms:

I do refer to it [*number line on laminated card under the board*] quite a lot, but I do use the number square as well. I do try and encourage the children that it's the same. (TY2)

The hundred square is easier than sometimes using the number line. Really, they're sort of similar things, but this goes zero to one hundred, this goes from one to one hundred, so it's the same really... (TY3)

The hundred square is like a number line, but with one bit on top of the other. (TY2)

This ambiguity also expressed by the children. When asked to talk about what they had done during lessons that day, comments included:

Using a number line [*means hundred square*], coloured it with pens, got numbers on it and the number line don't go up to one hundred, but the square does... [*A hundred square*] is a number line coz its got the one that goes up to a hundred. (Child 2.2)

We had to find the difference between the take-away sums. Thirty-nine take-away thirty-six are close together, so you get a number line or a hundred square and count down to the highest number. (Child 3.2)

It is interesting to note that after four (or more) years of relatively sustained experience with the number line in the development of addition and subtraction, the children's conceptual understanding of its relatively sophisticated nature appears to have progressed very little. They reiterate the ambiguities expressed by their teachers and much prefer the final compressions represented by the standard algorithms to solve addition and subtraction combinations, indicating that:

The vertical [*standardised*] way is the easiest. The number line is the hardest. (Child 5.5)

Coz it ain't the same answer as when I partitioned it... I've done the number line wrong... The partitioning way [*is better*]. (Child 4.1)

The focus of older children appeared to be upon the 'forward' and 'backward' 'jumps' used to resolve larger numerical addition or subtraction problems although these were frequently unsuccessful. For example, Child 5.1 preferred to use the standard algorithm to solve 24 add 32. After reaching the correct answer 56, she was requested to do it in another way. She then volunteered to use the number line, but knowing that the answer was 56, did not contribute to its successful use:

[*Drew a line, marked 0, 100, then 20 and 30, then 4 and 2 and then made jumps to add them*] You have to do little bits here [*in between 20 and 30*]. Put fifty-six there... Twenty-four add thirty-two... two and thirty and twenty and four... two add four [*jump from 2 to 4*] equals six. Twenty add thirty [*jump from 20 to 30*] equals fifty. Then we add them together... Fifty-six. (Child 5.1)

From an operational perspective, the partitioning process Child 5.1 uses, guides the jumps made on the number line, but these jumps have no relationship between what

is happening and the eventual outcome of the process (the sums: “ $2 + 4$ ” and “ $20 + 30$ ”). From a perceptual perspective, it is indicated that the line has numbers and marks (“little bits”), but apart from indicating a number position, there appears to be no conceptual sense of what the relationship between “a line” and “a point” may be.

In failing to express an understanding of the nature of the number line, particularly the correspondence between the number and segments on the line, the placing of fractions on the number line proved to be problematic. When asked to place more numbers on a 3 to 5 line segment, after marking the middle with number 4 correctly, Child 4.2 inserted fractions in the following order, near number 3:

One and a half [*wrote*  $1/2$ ], one and three quarters [*wrote*  $1/3$ ]... one over four [*wrote*  $1/4$ ], one over five [*wrote*  $1/5$ ]... (Child 4.2)

Ignoring the firstly marked number 4, as the middle of the line segment, signals that there was no attempt to pinpoint the position of these fractions. They were simply the child’s perceptions of the way fractions were ordered but clearly the child’s knowledge of fraction is being influenced by whole number considerations - the larger the number the larger the fraction.

The influence of whole number arithmetic on the construction of fractions, was also identified in the response of Child 4.3 who, given the same line segment 3 to 5, proceeded to write under each whole number fractions formed from the sum of the numerator and the denominator that would equal the whole numbers, explaining:

... Four ones [*writes*  $4/1$ , *under the* 5], three twos [*writes*  $3/2$ , *under the* 5]. ... You just have to add every number up to five. If you had three add two is five. It’s two threes... thirds it’s five. (Child 4.3)

However, such misconceptions may have arisen from the way in which the material was presented to them. After drawing a number line from 0 to 10 on the board, the Y4 teacher marked  $5/10$  in the middle, and then, in the order  $1/10$ ,  $9/10$ ,  $3/10$ ,  $4/10$ ,  $7/10$ ,  $1/2$  placed these fractions where numbers 1, 9, 3, etc. should have been. A problematic representation of fractions on the number line that was clearly confusing.

## DISCUSSION

The number line is clearly a very different representation to the number track (Skemp, 1989). However, evidence drawn from within the NNS (DfEE, 1999, 2006) suggests that there is no explicit explanation of the difference between the two. However, within the NNS, there appears to be an implicit assumption that those who use the number line are fully aware of not only its use as a tool but also of the conceptual understanding that underscores this use, an assumption possibly grounded in the strong research foundation attributing to the successful use of the number line in Dutch schools (Klein *et al.*, 1998).

In contrast, evidence from this one school suggests that teacher knowledge of the conceptual features associated with the number line was limited. Though applauding

its pedagogical benefit as a tool, there was little explicit or implied indication that this benefit had a formality based upon the repetition of a unit interval and the partition of this interval. Delivery emphasised specific perceptual features associated with a particular line (although this was tempered with representational ambiguity) and episodes such as ordering and moving backwards and forwards. As a consequence, the children's interpretation and use, whilst initially apparently successful from a procedural perspective, eventually became confused, and partially recognising their difficulty they decided that there were better tools - the potential of the number line to contribute to the development of a global perspective of the number system was not recognised.

Teachers, as well as children, make a personal construction of knowledge. It is conjectured that the recommended curriculum not only influenced what is taught, but also contributed to the formation of the teacher's subject matter knowledge. One consequence of this was that teacher discourse associated with the use of the line appeared to be common across all of the classes. Common perceptions and interactions, associated with ambiguous representation, provided a basis for the children's embodiments of the number line remained consistent throughout the year groups. The quality of the children's responses did not change significantly between Year 3 and Year 6. This feature, together with an over-riding 'preference' to label calibrated lines with whole numbers and the limited acknowledgement that an interval could be partitioned, suggests that the children's embodiment of the number line was formed from their relatively early experiences and changed very little with subsequent experience. Thus, by the time teachers wish to partition intervals for fractions and decimals, for many of the children, the notion of 'number line' carries an embodiment pre-loaded through prior active, linguistic and relational experience with whole number.

The primary school curriculum does not promote the number line as an abstract conception of the number system but as a concrete model that supports actions. Whether or not the authors of the curriculum supports assumed that the conceptual issues associated with the former may be raised as children deal with the varying aspects of the latter, clearly this link is an issue associated with teacher subject knowledge. The evidence from this study is that this would appear to be relatively superficial and consequently adds to the problems associated with a common classroom representation. If it were addressed pedagogical content knowledge would revitalise the emphasis placed on classroom use of the number line.

## References

- Cobb, P., Yackel, E., & Wood, T. (1992). A constructivist alternative to the representational view of mind in mathematics education. *Journal for Research in Mathematics Education*, 23, 12-33.
- DfEE (Department for Education and Employment) (1999). *The National Numeracy Strategy: Framework for Teaching Mathematics from Reception to Year 6*. London: DfEE Publications.

- DfES (Department for Education and Skills) (2006). *Primary National Strategy: Primary Framework for Literacy and Mathematics*. Norwich: DfES Publications.
- DES (Department of Education and Science) (1991). *Mathematics in the National Curriculum*. Her Majesty's Stationery Office, London.
- Doritou, M. (2006). *Understanding the Number Line: Conception and Practice*. Unpublished PhD., Mathematics Education Research Centre, University of Warwick.
- Dufour-Janvier, B., Bednarz, N., & Belanger, M. (1987). Pedagogical Considerations Concerning the Problem of Representation. In C. Janvier (Ed.), *Problems of Representation in the Teaching and Learning of Mathematics* (pp. 109-122). Hillsdale, NJ: Erlbaum.
- Herbst, P. (1997). The Number-Line Metaphor in the Discourse of a Textbook Series. *For the Learning of Mathematics*, 17 (3), 36-45.
- Klein, A. S., Beishuizen, M., & Treffers, A. (1998). The Empty Number Line in Dutch Second Grades: Realistic Versus Gradual Program Design. *Journal for Research in Mathematics Education*, 29 (4), 443-464.
- Lakoff, G. & Núñez, R. E. (2000). *Where Mathematics Comes from: How the Embodied Mind Brings Mathematics into Being*. New York: Basic Books.
- Lesh, R., Behr, M., & Post, T. (1987). Rational Number Relations and Proportions. In C. Janvier (Ed.), *Problems of Representation in the Teaching and Learning of Mathematics* (pp. 41-58). Hillsdale, NJ: Erlbaum.
- Ofsted (2004): Office for Standards in Education (England): Report to School.
- QCA (Qualifications and Curriculum Authority) (1999). *The National Numeracy Strategy: Teaching Mental Calculation Strategies. Guidance for Teachers at Key Stages 1 and 2*. Qualifications and Curriculum Authority: London.
- Skemp, R. R. (1989). *Mathematics in the Primary School*. London: Routledge.

# **MODELLING THE TRAVELLING SALESMAN PROBLEM: RELATIONS BETWEEN THE WORLD OF MATHEMATICS AND THE REST OF THE WORLD**

Roxana Grigoraş and Stefan Halverscheid

University of Bremen

*Mathematical modelling implies the linkage of mathematical models to clearly stated circumstances in the real world. The modelling cycle to a two-dimensional framework addresses the real world, the mathematics world, as well as the transitions between the phases in these worlds. The framework is used to analyse group discussions on the travelling salesman problem. This problem was given to students aged 11 to 13 in the form of a structured task, but without further teacher intervention. Their dialogues were analysed within this framework. Certain stages of the modelling cycle were worked on in parallel. These parallel structures were linked to mathematical and social aspects.*

## **INTRODUCTION**

Building knowledge with mathematical models is a complex undertaking. Mathematical modelling implies, among other processes, the linkage of mathematical models to clearly stated circumstances in the real world. “The concept of modeling can describe the applicability of mathematics and its relation to the “real” world in a very general and, at the same time, quite elementary way. Whenever mathematics is applied to describe and clarify objective situations and to solve real problems, a mathematical model is constructed (Heymann, 2003).”

It is a consensus in the research on mathematical modelling that this activity usually proceeds in phases. These phases are addressed in the literature by several modelling cycles (e.g. Berry & Davies, 1996; Haines & Crouch, 2001), which are representing methodological approaches for mathematical modelling. Peter-Koop (2005) for instance examined the modelling process at children between age 8 and 10, by going several times through the modelling cycle. Many other studies involve students at the age of 14 and older. The aim of this paper is to address and analyse the modelling process at older students between ages 11 to 13 years.

An important role in knowledge construction by students is assigned to the teacher. Blum & Leiss (in press) demonstrate how teachers push students in modelling processes in the direction of a solution of the problem they have in mind.

## **Research questions and design**

The study is part of a mathematics education research project with the aim of gathering a profound understanding of knowledge construction in contexts of mathematical modelling. Students were given the modelling task to discuss the travelling salesman problem (TSP), a well-known application, tracing back to

Hamilton's game “tour around the world”. This graph-based game led to the definition of what we nowadays refer to as Hamiltonian path and Hamiltonian cycle.

Following research questions are tackled in this project:

- Q1. How is the modelling activity of establishing links between the rest of the world (often referred to as the ‘real world’) and the math world done?
- Q2. Which mathematical tools are used by the students? And how are they used?
- Q3. Do patterns of arguments and working procedures occur which seem typical of modelling?

### SEPARATION OF WORLDS IN THE MODELLING CYCLE

Following Kaiser and Maaß (2007),

the integration of modelling examples in mathematical lessons can lead to the development of students' application-oriented beliefs...students at lower secondary level are able to develop modelling competencies which include meta-knowledge of modelling processes.

For building such meta-knowledge, it is important for teachers to address and assure at least following three major issues. The student must know (i) in which phase to start and in which phase to end, (ii) whether the phase is ‘located’ in the mathematical world or in the rest of the world, (iii) what kind of technique is appropriate for each phase.

#### Real world vs. Mathematical world

Helping pupils in solving real-world problems, German mathematics teachers support and approach a 3-stages-scheme (Peter-Koop, 2004): *find the question, do the calculation, and give the answer*. This represents a simplified form of the traditional modelling cycle, which was initially introduced by Penrose (1978), but can also be found in Blum and Leiss. It describes seven phases or stages that need to be passed during the mathematical modelling process (Houston, 2007). In Figure 1a, the modelling cycle as described by Berry & Davies (1996), Haines & Crouch (2001), and Crouch & Haines (2004) is represented.

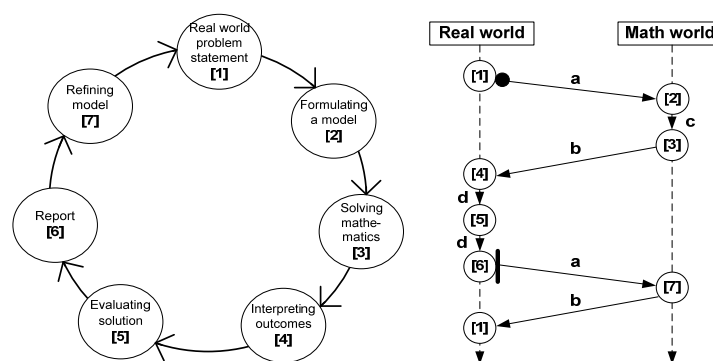

Figure 1. a) The idealised modelling cycle and b) possible world separation in modelling cycle.

A study conducted by Peter-Koop (2004) demonstrates that ‘even’ pupils of 4th class can successfully approach modelling tasks with Fermi type problems. Moreover, already at this age, modelling cycles are not gone through in an organised manner. Peter-Koop shows that modelling and interpretation, as proper activities taking place during the modelling process, interfere and interact in a multi-cyclic manner. The analyses by Borromeo-Ferri (2006) take a cognitive perspective, in particular transitions between different stages of the modelling process occur in a complex manner.

Modelling activities in our mathematics education context are referred to as those complex actions through which posed real-world “problems” are solved by mathematical means, according to the knowledge base owned by the modeller(s). The framework that we propose in Figure 1b, maps the seven phases of the modelling cycle of Figure 1a to the two dimensions that represent the real world and the math world.

## EMPIRICAL STUDY

### Empirical design

Our framework was tested and studied in an experimental classroom environment. A total of 28 students of age between 11 and 13 years were involved. They were organised in seven teams. Each team had about 90 minutes of time to work on the TSP. The TSP itself was posed in three stages described in the following. The teacher’s role was limited to give information on the real world (like distances or train schedules or maps) to the students on request and to issue the text of a stage after the previous stage was finished. No mathematical hints or suggestions for building a model were given.

The experiment was recorded on video tape and transcripts of the students’ discussions were worked out afterwards and analysed in a sequential, interpretative analysis.

### Task description

**Stage 1.** A salesman has to travel through eight cities in Germany. What kind of information would you search for, if you had to plan the salesman’s trip?

**Stage 2.** Write a letter of one page to the salesman and provide him/her three suggestions how you would plan the trip.

**Stage 3.** The salesman responds to your letter:

*“Dear planning group, thank you for the interesting suggestions for my trip. For me two things have priority: (1) I have to travel only once through each of the cities of Bremen, Hamburg, Berlin, Düsseldorf, Cologne (Köln), Koblenz, Bonn and Frankfurt. (2) I intend to finish the trip as fast as possible. Herewith I give you the assignment of finding a travel tour, which best meets my requirements. Please do explain me in a detailed manner, how you developed the trip suggestion. Yours sincerely, The travelling salesman.”*



All three stages describe the real world, i.e. the world the travelling salesman thinks in. Therefore also natural language is used. The main expectation of the described framework was that students come up with finding the shortest tour for the salesman, according with the distances between cities. However, the study was carried out during a long geometry course in which graphs and optimisation did not play a role. In fact, graphs did not appear as mathematical tools in the students' school career before.

## FINDINGS

Those students who worked with a map extracted the relevant cities. An approximate mapping of distances between these cities led to a first generation of graph-like structures - consisting only of the nodes that represent the cities under consideration.

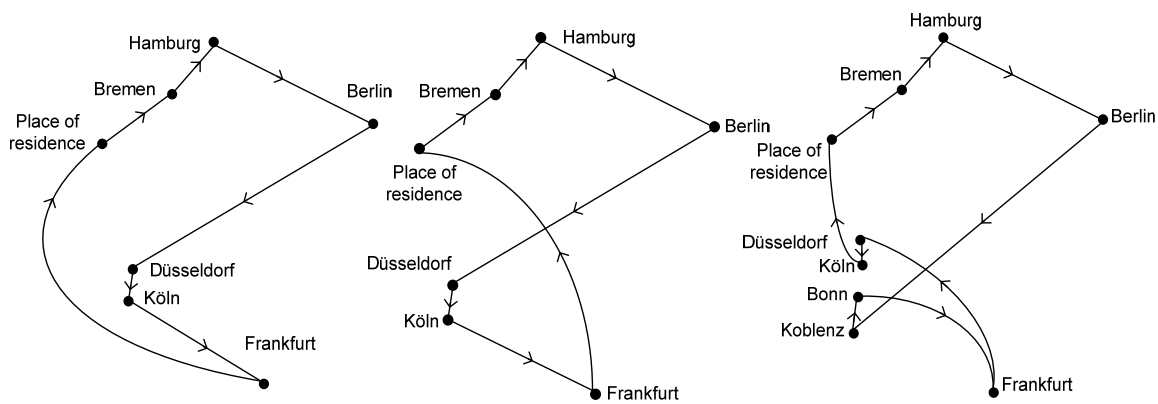

Figure 2. Three different graphs 'yellow' team.

Figure 2 shows three different solutions of the travelling plan that were developed by the 'yellow' team and Figure 3 shows the graphs of the 'green' team and the 'blue' team. Note that the graphs in Figure 3 contain also other cities than graphs in Figure 2. That is due to the fact that students belonging to the 'green' and 'blue' teams had the initiative of making assumptions and chose on their own the cities already in stage 2.

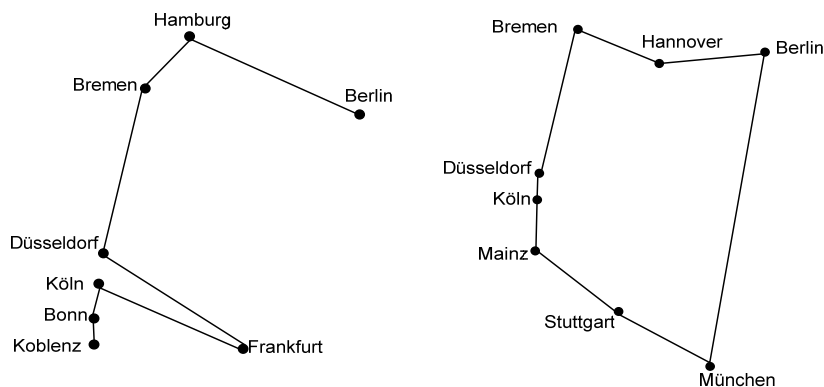

Figure 3. Graphs of 'green' and 'blue' team.

## Strategies of ‘mathematisation’ during the three stages

In this subsection we describe the different approaches in a purely descriptive-observational manner.

**Stage 1.** The students abstracted some relevant parts of the real world under consideration. In general, the students explored the situation in the real world and generated various aspects. The most important one is definitely the location of the different cities, but other issues - in most cases less important - were also mentioned during their discussions. As an effect of talking to each other, as members of the same team, the students generated per group the same concepts.

**Stage 2.** The most remarkable aspect during the second phase is the fact that most students included in their answer, parts which would rather belong to stage 3. The students have made assumptions, which helped them to solve the ‘real’ problem.

One group out of the three (‘yellow team’) brought in immediately the optimisation aspect, whereas the other two teams gave suggestions in terms of transportation means, staying over the night, etc. Two teams looked at stage 2 as at a typical ‘letter’ focused on aspects which could play a role in a journey, things you can *plan*, not as a *solution*.

**Stage 3.** The ‘blue’ team did not say anything about alternative tours, its unique solution looks more or less like a cycle. It seems that they ‘translated’ the problem into distances and intuitively aimed to find an optimal solution. The ‘green’ team had several problems. They wrongly located Frankfurt on the map and also did not close the cycle, meaning that the salesman never gets back home. The ‘yellow’ team came up with three solutions. They introduced the tour concept by saying: “The tour starts at the salesman’s place of residence ... and also ends up again there”. But they did not consider the distance from the place of residence to the first city that the salesman has to visit.

### Analysis of links between the two worlds

We give some observations about the students’ answers, in terms of a-b-c-d-transitions according to Figure 1.b. Consider two cities P and Q in the real world. When the students drew two vertices, P and Q, they made an a-transition. Representation of the road by an edge between P and Q is an a-transition again. When introducing a label to the edge, that is a c-exploration in the math world. Relating it to the distance, cost or time for travel would be a b-transition. A calculation in the math world before this b-transition shows that the c-exploration has possibly gone further and has become a c-experimentation (proof).

This transition turns out to be the most delicate and challenging part when assessing students results, since this rendering does not necessarily follow a specific schema. In the sequential analysis, it was sometimes necessary to consider the context of a longer part of the discussion to classify the transitions between the worlds.

**Group dynamics:** In the following, students S1, S2, ..., S5 are arguing about the relevance of certain given data for the mathematical aims, which is in fact an

indicator of exploring the real world and the transition to the formulation of the mathematical model; this is, first of all, an example of a transition  $[1] \rightarrow a \rightarrow [2]$ :

- S.2: What does he want in this town? (some answers evasively given, but none of them can be heard from the video tape.)
- S.3: We do not need this!
- S.4: But first, the second question. First, the third question. In which order? (...) Listen (...) Then one can say in which (...)

The order of the cities is mentioned five times by student S2. Then, since the other students (mainly S3 and S1) do not consider this idea, S2 gives up the idea after eight minutes of trying.

**Very quick cycles:** In the following a mathematical strategy is approached; this is an example of transition  $[2] \rightarrow c \rightarrow [3]$ , but just at the beginning, there is a transition  $[3] \rightarrow b \rightarrow [4] \rightarrow d \rightarrow [5]$ :

- S.2: Here, when we...look [to S.1] again here. Then we can come back. (pause) That is totally stupid, because one drives around...
- S.4: Yes, ok, do we want to do it this way? Hey we are currently doing, we are not yet (...) You wanted to do stage 2 and now we do stage 2 and you start with (...) [to S.1]
- S.2: Firstly, one has to establish a route, so that one saves energy!

Again for reasons of group dynamics, this idea vanishes soon and is no longer discussed. It is striking that those ideas are lost in particular that would mean to start a new mathematical topic - something several groups are somehow reluctant to.

**Parallel thoughts:** Forty minutes later, while deciding for an optimal route, the students are passing from mathematical world to the real world, performing some kind of intuitive checking ( $[3] \rightarrow b \rightarrow [4]$ ), but without performing a mathematical argument:

- S.2: I have Bremen, Hamburg, Kiel, Berlin
- S.1: I also have (the others agree...)
- S.2: afterwards Stuttgart, then Munich
- S.4: Exactly

The mathematics (in form of the sketched graphs) is discussed in the language of the real world. From the transcript, it seems that some students even do not have the feeling of entering the mathematical world.

Other parallels were sometimes observed between c and d. Once having agreed on the solution, two modelling strategies can be interpreted, while the students are documenting the result (transition  $[4] \rightarrow d \rightarrow [5] \rightarrow d \rightarrow [6]$ ):

- S.4: Yes! Yes, that is obvious from the text.
- S.5: No, it is not said in the text.
- S.1: Ah, you are stupid.
- S.5: Because you are currently in Bremen.

When student S5 refers to the text, he might also perform a transition [1]→a→[2].

## SUMMARY

Although the students never heard about graph theory before, the modelling activity of establishing links between the worlds was done in this graph-based way by extracting important concepts and aspects from the real world (map of Germany) to a mathematical graph (see Q1.). The mathematical tools used were graphs and on the basis of these graphs, optimisation issues, such as distance, time, or costs were discussed (see Q2.). With respect to Q3., it can be said that the main reoccurring argument, typical for modelling, is to reduce unrelated aspects from the real world and to ‘mathematise’ the reduced real world.

It was often not clear whether the students are in the mathematical world or in the rest of the world. The correspondences within real world and mathematical world appear in parallel as d and c transitions, but often, the c transition in the mathematical world is not mentioned explicitly. In a similar vein, a and b transitions occur in pairs and are hard to distinguish from each other.

Considerations of mathematical nature were very short, and mainly intuitive. If a question leaves the mathematics open, there is a tendency of students to answer the questions rather intuitively than based on classical mathematical reasoning. This is a possible answer why for some students it was not clear what the problem has to do with mathematics. In future research, it should be examined whether the transitions in pairs a-b or c-d also appear during the work on other tasks, too. It would also be interesting to investigate how exploring and experimenting occur in modelling processes and how do the students acquire knowledge while going through these particular learning techniques.

## References

- Berry, J. & Davies, A. (1996). Written reports. In C.R. Haines and S. Dunthorne (Eds.), *Mathematics Learning and Assessment: Sharing Innovative Practices*, London, Arnold.
- Blum, W. & Leiss D. (in press). How do students and teachers deal with mathematical modelling problems? The example “Filling up”. In Haines et al. (Eds.), *Mathematical Modelling (ICTMA 12): Education, Engineering and Economics*. Chichester: Horwood Publishing.
- Borromeo-Ferri, R. (2006). Individual Modelling Routes of Pupils - Analysis of Modelling Problems in Mathematics Lessons from a Cognitive Perspective. In: Haines, C. et al. (Eds.), *Mathematical Modelling (ICTMA 12): Education, Engineering and Economics*. Chichester: Horwood Publishing, pp. 260-270.
- Crouch, R. & Haines, C. (2004). Mathematical Modelling: transitions between the real world and the mathematical model. *International Journal of Mathematical Education in Science and Technology*. 35(2), 197-206.
- Haines, C. & Crouch, R. (2001). Recognizing constructs within mathematical modeling. *Teaching mathematics and its applications*, 20(3), 129-138.

- Haines, C., Crouch, R., & Fitzharris, A. (2003). Deconstructing mathematical modeling: approaches to problem solving. In Q. Ye, W. Blum, S.K. Houston et al. (Eds.), *Mathematical Modelling in Education and Culture*. Chichester, Horwood Publishing.
- Houston, K. (2007). Assessing the “Phases” of Mathematical Modelling. In *Modelling and Applications in Mathematics Education - The 14<sup>th</sup> ICMI Study*. Berlin, Springer, 249-256.
- Heymann, H.W. (2003). *Why Teach Mathematics? A Focus on General Education*. Dordrecht, Kluwer.
- Kaiser, G. & Maaß, K. (2007). Modelling in lower secondary mathematics classroom - problems and opportunities. In *Modelling and Applications in Mathematics Education - The 14<sup>th</sup> ICMI Study*. Berlin, Springer, 99-108.
- Penrose, O. (1978). How can we teach mathematical modelling?. *Journal Mathematical Modelling for Teachers*, 1(2), 31-42.
- Perkkilä, P. & Aarnos, E. (2007). Children’s talk about mathematics and mathematical talk. Refereed and presented at CERME5 (European Society for Research in Mathematics Education) Conference. Larnaka.
- Peter-Koop, A. (2004). Fermi Problems in Primary Mathematics Classrooms: Pupils’ Interactive Modelling Process. Technical Report, University of Oldenburg, Germany.

# **DURABILITY AND MEANINGFULNESS OF MATHEMATICAL KNOWLEDGE - THE CASE OF THE DERIVATIVE CONCEPT**

Markus Hähkiöniemi

University of Jyväskylä

*In this paper I study meaningfulness and durability of five high-school students' knowledge of the derivative concept. The students had been taught the derivative emphasizing graphical properties of the derivative and limiting processes inherent in the derivative. They participated in two task-based interviews: one administered when they were studying the derivative and one administered a year later. In the analysis of the latter interviews it was found that they still had good potentials to investigate the derivative in a graphical context. However, their knowledge of the definition of the derivative had almost totally vanished. The graphical context seemed to also be close to the students' experiential world and give meaning to the concept.*

## **INTRODUCTION**

In this paper I study factors that influence how meaningful students experience mathematics that they have learnt and factors that influence the durability of their knowledge over time. It is a well known problem that students tend soon to forget what they have learnt and that they consider mathematics as a set of rules that have no reasons. Presumably these problems are interconnected.

In line with Georghiades (2000) the durability of knowledge means in this study the time that knowledge remains in a person's repertoire of reasoning. Thus, durable knowledge is not only remembered but it can be used in reasoning processes. The durability of knowledge can be seen as prerequisite to transfer learning from one context to another. It has been widely accepted that understanding and conceptual knowledge which is rich in relationships promote durability and transfer of mathematical knowledge (Bransford, 2000; Hiebert and Lefevre, 1986; Hiebert and Carpenter, 1992). In the case of the derivative concept Repo's (1996) study has shown that when the control group had been taught emphasizing connections its better learning results in the post-test had preserved also in the delayed post-test 6 months later.

In this study meaningful mathematical knowledge means that a student feels it personally meaningful or experientially real for him/her. According to Gravemeijer & Cobb (2006), a situation is experientially real for students if they "can reason and act in a personally meaningful manner". Also mathematics may be real for students and the aim of learning is that students develop new experientially real mathematical ideas which become part of their reality (Gravemeijer & Cobb, 2006). In this study I try to interpret what elements of the derivative the students feel meaningful by examining what personal meanings they give to the concept, what they describe to help them to think about the derivative and how they reason when solving problems. The personal meanings refer to what a person describes the concept to mean. Thus, it

is similar to personal concept definition (Tall & Vinner, 1981) but it should be emphasized that students do not necessarily try to describe what the mathematical definition is. According to, for example, Attorps's (2006) study, even teachers have difficulties in describing what a concept means and their descriptions have often a procedural nature.

The 17-year longitudinal study conducted in Robert B. Davis Institute for Learning has given insights also to the durability and meaningfulness of mathematical knowledge (see, e.g. Maher, 2005; Francisco & Maher, 2005; Uptegrove & Maher, 2004). According to Francisco and Maher (2005), durability and meaningfulness of knowledge is enhanced if building of knowledge begins from students' ideas and students develop ownership of the mathematics they are doing. Also emphasizing basic ideas, using complex tasks instead of dividing them into simple ones, using strands of problems that are designed around same mathematical topic, emphasizing meaningful justifications instead of rigorous proofs and collaboration among students helps to build durable and meaningful knowledge (Francisco & Maher, 2005). In such conditions the students of the study have, for example, solved problems building isomorphism to previous problems which were solved several years ago (e.g., Uptegrove & Maher, 2004).

As a framework in studying students reasoning I use "three worlds of mathematics" (Tall, 2004). In the embodied world students may reason and make thought experiments with things that can be perceived in the physical or in the mental world. The symbolic world consists of using symbols for calculation and for thinking about concepts. In the formal world mathematics is considered as axiomatic system.

This study is continuation of a previous study (Hähkiöniemi, 2004, 2006) in which a class of Finnish 11<sup>th</sup> grade students was taught the derivative concept starting from the embodied world in which the students examined qualitatively the rate of change of function from graphs. At this stage they were taught, for example, to move a hand along the graph and to place a pencil as a tangent to sense the rate of change. After that the class engaged in solving the problem of how to estimate and determine the instantaneous rate of change. After this problem the derivative was defined as a limit of the difference quotient. After the five-hour teaching sequence five students participated in task-based interviews. It was found that they used the representations of the increase, steepness, horizontalness and tangent of the graph in reasoning and demonstrated conceptual knowledge by relating properties of the function and the derivative concepts. All the students used also some image of the limiting process underlying the derivative concept. Two students (Daniel and Samuel) even used the limiting process to interpret that an unknown form of the limit of the difference quotient gives the derivative at a point.

The aim in this study is to investigate how the students reason about the derivative one year later. Particularly, it is investigated what meanings they give to the

derivative, what things they consider as helpful thinking tools and how durable different elements of their knowledge of the derivative have been.

## METHODS

The same five students who participated in the teaching sequence of the derivative and in the task-based interviews (Goldin, 2000) in the autumn of 2003 were interviewed again in the autumn of 2004 using similar tasks. Each interview lasted about one hour and included the following tasks:

1. a) What is the definition of the derivative? b) What does the derivative mean?  
(In answering 1a the other students expect Tommi answered as they were describing what the derivative means. Thus, they were probed more on this and later asked what the “official” mathematical definition of the derivative is. After 1a and 1b the formal definition was given and the student was asked to reason why the definition is stated as it is.)
2. a) The graph of a function  $f$  is given in the figure. What observations can you make about the derivative of the function  $f$  at different points?  
b) Sketch the graph of the derivative function of  $f$  as accurately as possible.
3. The graph of a function  $g$  is given in the figure. Sketch the graph of the function which derivative function is  $g$  as accurately as possible.
4. Determine the derivative of the function  $f(x) = -2x^3$  at the point  $x = 2$ . (If the student used a differentiation rule, he/she was asked to use some other methods to determine or estimate the value of the derivative.)
5. a) Which aspects of the derivative have been useful or important for you? b) Which things in your opinion help to think about the derivative? c) Which things in your opinion are distracting or causing troubles when thinking about the derivative?

The interviews were video-recorded and transcribed. From each of the interviews it was analyzed what meanings the students gave to the derivative, what properties of the function and derivative concepts they coordinated, how they used the limit of the difference quotient and interpreted the meaning of it and how they used different kinds of representations for thinking about the derivative.

## RESULTS

### Personal meanings of the derivative

In answering what the derivative means the students referred to the slope of a tangent, to the rate of change and to the differentiation. When asked which things help in thinking about the derivative, the students referred to similar elements. Main points of the students' answers are presented in Table 1. Daniel and Tommi answered spontaneously that the derivative means the slope of a tangent. Also Samuel referred to the tangent spontaneously by gesturing a tangent line in the air and by mentioning the horizontalness of the tangent (see Table 1). Also Susanna referred to the slope of a tangent when she was asked what the derivative means graphically. Tommi, Samuel, Susanna and Niina referred also to the rate of change of a function.



	Meaning of the derivative	Things that help in thinking about the derivative
Niina	<ul style="list-style-type: none"> <li>• That the <math>f(x)</math> is <math>f \cdot x</math> [<math>f'(x)</math>].</li> <li>• It [derivative] can be used to calculate the speed of the function.</li> </ul>	Maybe graphs. ... With them you could get it more concrete. ... You can understand it better.
Susanna	The derivative is the going of the function [sketches a graph in the air].	[Tangent helps] at least to get some understanding of what the derivative means.
Tommi	<ul style="list-style-type: none"> <li>• Was it connected to limits?</li> <li>• It [slope/derivative] represents whether the function decreases or increases, and how fast.</li> </ul>	It is useful to think what the function is going to do next. Is the value going to increase, decrease or stay the same? With this you can think what the derivative could be.
Samuel	The derivative is a curve, which represents the change ... or the rate of change of the function. ... It is the direction and the value of the change [sketches a tangent in the air]. If the tangent is horizontal, then the rate of change is zero.	Draw a tangent and look whether it is descending or ascending. If descending, then negative. If ascending, then positive. If horizontal, then zero.
Daniel	<ul style="list-style-type: none"> <li>• [Draws a graph and a tangent line.] ... Derivative of the curve at this point is the slope of the line. Change in <math>y</math> divided by the change in <math>x</math>.</li> <li>• The opposite of integrating. ... By differentiating the integral function you get the original function.</li> </ul>	The slope of a line was taught at secondary school. That helped to understand how the derivative is calculated. ... With that you can always think about it. ... Of course, from the graph it is easy to see. ... It is easier to think about the derivative or what it concretely is when you can just see it.

Table 1. Students' explanations for the meaning of the derivative and their opinions on what things help to think about the derivative

All the students, except Tommi, referred also to differentiation procedure or gave an example of differentiation but only for Niina this was the first explanation for the derivative. The presence of the differentiation is understandable because of the heavy emphasis of it in the curriculum. However, all the students gave also an embodied meaning to the derivative. Samuel and Susanna (see above) used also gestures in explaining what the derivative is. Also in answering what helps to think about the derivative the students mentioned elements of the embodied world such as graphs, tangent lines and change of the function. As Daniel expressed it "it is easier to think about the derivative or what it concretely is when you can just see it". It seems that the graphical and embodied elements of the derivative were experientially real for the students and gave meaning to the abstract mathematical concept.

Tommi was the only student who related the limit concept to the derivative spontaneously. His first answer to what the definition of the derivative is was: “I don’t remember these things. Can I look it from the book? ... No idea. ... Was it connected to limits?” When given the definition and prompted in examining its meaning he could interpret that the difference quotient means a slope of a secant line but could not figure out what happens in the limiting process. That was the closest that any of the students got in interpreting the meaning of the definition. Tommi was also the only student who spontaneously suggested using definition in task 4 and described the procedure of using it although he could not simplify the expression because of the third power.

### Connections between a function and its derivative

In addition to explaining the meaning of the derivative, the students also used the mentioned elements in their reasoning processes. In Tasks 2 and 3 Susanna was the only student who did not manage to draw the requested graphs. In these tasks the students related several properties of the function and derivative concepts. In addition to doing this implicitly by drawing the requested graphs, they also explicitly verbalized these connections either spontaneously or after being asked for arguments. The connections they made are presented in Table 2 with examples of students’ verbalizations. Despite the two last connections, the connections were made by all the students.

Function	Derivative	How the connection was made	Example
<b>linear</b>	Constant	straightness, tangent does not change, constant increase	Samuel: Because it is a line and the tangent joins the line. It increases constantly.
<b>maximum/ minimum</b>	Zero	horizontalness, slope of tangent is zero, pencil as a tangent, graph does not increase or decrease	Niina: Because the function goes like. I mean it does not increase or decrease.
<b>increases/ decreases</b>	positive/ negative	increase/decrease of the graph, sign of the slope of the tangent, pencil as a tangent	Susanna: Positive when the line is ascending and negative when it is descending.
<b>steepest upward/ downward</b>	maximum/ minimum	steepness, pencil as a tangent, turning point, magnitude of the increase	Niina: When the graph increases or decreases steepest.
<b>a cusp</b>	not defined	tangent is not defined, pencil as a tangent	Daniel: You can draw the derivative in any direction [moves a ruler as a tangent]
<b>concave up/down</b>	increases/ decreases	translation of the tangent, pencil as a tangent, drawing tangents in the air, change in $y$ increases, getting steeper, accelerating increase	Tommi: The graph starts to go steeper upward [traces the graph]. Then the increase accelerates.
<b>concave up/down</b>	<sup>2</sup> <sup>nd</sup> derivative is positive/ negative	translation of the tangent, pencil as a tangent, getting steeper, accelerating increase	Samuel: [Moves pencil as a tangent.] It decreases all the time more.

Table 2. Connections between the graph of the function and the derivative

Also Susanna stated these connections explicitly in Task 2a but was still not able to draw a graph in Task 2b. The students used the same representations as in the 2003 interviews (Hähkiöniemi, 2006) for thinking about the derivative in a graphical context and for making the connections. They all used the position of a tangent, the increase/decrease of the graph of a function, the steepness of the graph of a function, and the horizontalness of the graph of a function. In addition to these, Daniel, Samuel and Tommi used placing a pencil or a ruler as a tangent to the graph and moving it along a graph (Fig. 1). For example, Tommi used this in Task 2a when asked what could be said about the derivative of the derivative function:

Tommi: Derivative of the derivative. [Places a pencil as a tangent.] ... Is it positive at those intervals and negative there [points at the correct intervals].

Interviewer: How did you see that?

Tommi: I just thought that the derivative represents the slope there. Then to which direction it is going to turn next when we go forward [rotates hand and pencil in the air].

Interviewer: To which direction it is turning?

Tommi: [Places the pencil as a tangent.] It turns all the time upward from this point and then it starts to turn downward [moves the pencil as a tangent].



Figure 1. Tommi moves pencil as a tangent along the graph in Task 2a.

Susanna and Niina seemed to be uncertain in their reasoning and said this aloud several times. They also needed explicit questions (e.g., where the derivative is positive) to make observation whereas the other three students made most of the observations spontaneously. They also misidentified the increase/decrease of the derivative with increase/decrease of the function. This happened even though they had located the intervals where the derivative is positive/negative and related these to the increase/decrease of the function (see Table 2).

## CONCLUSIONS AND DISCUSSION

It was found that the students' had built durable personal meanings for the derivative concept. The personal meanings were related to the derivative as a concept in the embodied world but they also referred to procedural aspects of using differentiation rules. These personal meanings are somewhat similar to personal concept definition (Tall & Vinner, 1981) but the students seemed to describe what the derivative means instead of what the mathematical definition is. The students also expressed that the embodied world concretized the derivative concept, made it experientially real for them and related the concept to their previous knowledge.

The students also connected several properties of the function and the derivative concepts in the embodied world. This indicates that their potential to investigate the derivative in the embodied world had preserved. They also reasoned with the representations in similar ways as a year before. It is particularly interesting that they used the representation of placing some concrete object as a tangent to a graph. Similarly to the 2003 interviews it was used especially when needed deep thinking. This suggests that this simple representational tool (developed for and used in teaching the derivative) may be effective and helpful tool for students and stay for a long time in their capacity for reasoning. The students' use of this representation also illustrates how placing actually an object as a tangent instead of just imagining it may make a big difference for reasoning. This supports other research results which suggest that gestures have a great role in mathematical thinking (e.g., Radford and al., 2003). The students had still good potentials for reasoning in graphical context, but their knowledge of the limit of the difference quotient and underlying limiting processes had almost totally vanished. None of them were successful in describing why the given definition of the derivative is formulated as it is.

Although these results concern only a specific kind of teaching and only small number of students was studied, it indicates the need to investigate more thoroughly the factors that influence the durability of mathematical knowledge. The cases of the five students suggest that it may be that the meanings constructed in the embodied world increase durability of mathematical knowledge, particularly, the kind of durability which does not refer to remembering but to reasoning capacity. For example, in Viholainen's (2006) study, it was found that mathematics subject teacher students had in many cases a week capacity of reasoning about the basic concepts of calculus when they were tested without having just dealt with these. This study suggests that the embodied world could activate students to think mathematically instead of just applying memorized rules. In this world it could be possible for students to build a meaningful and durable basis for learning.

## References

- Attorps, I. (2006). *Mathematics Teachers' Conceptions about Equations*. Doctoral dissertation. University of Helsinki. Department of Applied Sciences of Education. Research Report 266.
- Bransford, J., Brown, A., & Cocking, R. (Eds.) (1999). *How People Learn: Brain, Mind, Experience, and School*. Washington, D.C.: National Academy Press.
- Francisco, J. & Maher, C. (2005). Conditions for promoting reasoning in problem solving: Insights from a longitudinal study. *Journal of Mathematical Behavior*, 24(3-4), 361-372.
- Georghiades, P. (2000). Beyond conceptual change learning in science education: Focusing on transfer, durability and metacognition. *Educational Research*, 42, 119-139.
- Goldin, G. (2000). A scientific perspective on structured task-based interviews in mathematics education research. In A. Kelly & R. Lesh (Eds.), *Handbook of Research Design in Mathematics and Science Education*. Mahwah, NJ: Erlbaum, 517- 545.

- Gravemeijer, K. & Cobb, P. (2006) Design research from the learning design perspective. In J. van den Akker, K. Gravemeijer, S. McKenney, & N. Nieveen (Eds.), *Educational design research* (pp. 17-51). London: Routledge.
- Hiebert, J. & Carpenter, T. (1992). Learning and teaching with understanding. In D. Grouws (Ed.) *Handbook of Research on Mathematics Teaching and Learning*. New York: Macmillan, 65-97.
- Hiebert, J. & Lefevre, P. (1986). Conceptual and procedural knowledge in mathematics: An introductory analysis. In J. Hiebert (Ed.) *Conceptual and Procedural Knowledge: the Case of Mathematics*. Hillsdale, NJ: Erlbaum, 1-27.
- Hähkiöniemi, M. (2004). Perceptual and symbolic representations as a starting point of the acquisition of the derivative. In M. Høines & A. Fuglestad (Eds.) *Proceedings 28<sup>th</sup> Conference of the International Group for the Psychology of Mathematics Education* (Vol. 3, pp. 73-80), Bergen, Norway: PME.
- Hähkiöniemi, M. (2006). *The Role of Representations in Learning the Derivative*. Doctoral dissertation. University of Jyväskylä. Department of mathematics and statistics. Report 104.
- Maher, C. (2005). How students structure their investigations and learn mathematics: insights from a long-term study. *Journal of Mathematical Behavior*, 24(1), 1-14.
- Radford, L., Demers, S., Guzmán, J., & Cerulli, M. (2003). Calculators, graphs, gestures and the production of meaning. In N.A. Pateman, B.J. Dougherty, & J.T. Zilliox (Eds.), *Proceedings 28<sup>th</sup> Conference of the International Group for the Psychology of Mathematics Education* (Vol. 4, pp. 55-62), Hawaii, USA: PME.
- Repo, S. (1996). *Matematiikkaa Tietokoneella. DERIVAATAN Käsitteen Konstruoiminen Symbolisen Laskennan Ohjelman Avulla*. [Mathematics in the Computer Environment. Constructing the Concept of the Derivative by Means of the Computer Algebra Program.] University of Joensuu, Publications in education, N:o 33.
- Tall, D. (2004a). Thinking through three worlds of mathematics. In M. Høines & A. Fuglestad (Eds.) *Proceedings 28<sup>th</sup> Conference of the International Group for the Psychology of Mathematics Education* (Vol. 4, pp. 281-288), Bergen, Norway: PME.
- Tall, D. & Vinner, S. (1981). Concept image and concept definition in mathematics with particular reference to limits and continuity. *Educational Studies in Mathematics*, 12(2), 151-169.
- Viholainen, A. (2006). Why is a discontinuous function differentiable? In J. Novotná, H. Moraová, M. Krátká, & N. Stehlíková (Eds.), *Proceedings 30<sup>th</sup> Conference of the International Group for the Psychology of Mathematics Education* (Vol. 5, pp. 329-336), Prague, Czech: PME.
- Uptegrove, E. & Maher, C. (2004). Student building isomorphisms. In M. Høines and A. Fuglestad (Eds.) *Proceedings 28<sup>th</sup> Conference of the International Group for the Psychology of Mathematics Education* (Vol. 4, pp. 353-360), Bergen, Norway: PME.

# **HOW PRE-SERVICE TEACHERS USE EXPERIMENTS FOR UNDERSTANDING THE CIRCULAR BILLIARD**

Stefan Halverscheid  
University of Bremen

*Small groups of pre-service teachers are given a circular billiard table and the task whether every billiard ball returns after some time to its starting point. The epistemic actions in the problem solving situation and the experiments with the billiard table are analyzed simultaneously. The groups treat the experiments in two different ways. One type of groups focuses very much on the problem solving character of the task and uses the experiments only at the beginning of a certain problem. The other type considers the experiment as a part of task; they use experiments more frequently and try to verify theoretical results of the problem solving process also by experiments.*

## **INTRODUCTION**

### **Experiments and mathematics**

Although experiments as such may be rather considered typical for science than for mathematics, many mathematical activities, representations, and models are strongly connected with experiments. Even more so, experiments are regarded as very popular by high school students (for Britain, for instance, see the GCSE science report 2005). The need for a close co-operation between science education and mathematics education has been stressed at various occasions (Steiner, 1990).

Needing some mathematics to understand experiments in science classes is an important mathematical experience for students. For university students in mathematics, and pre-service teachers in particular, deductive thinking is predominant. Hersh (1991) underlines the different roles of deductive and inductive thinking as the “front” and the “back” of mathematics.

There are, of course, a number of important research articles on the role of experiments for the teaching and learning of science. It is not the place here to elaborate on this discussion, also because for the differences between research in mathematics education and sciences education, quite some care is needed (Artigue, 1990).

In this study here, a problem solving task is given to a group of pre-service teachers together with the opportunity to carry experiments. The research question at the beginning of the study was to investigate how the students link the epistemic actions of the problem solving task with the use of experiments.

### **Epistemic actions model of abstraction in context**

The epistemic actions model for abstraction in context is aimed at providing a framework for a micro-level description and analysis of processes of abstraction. The word “abstraction” stands for the emergence of new knowledge constructs by vertical organization of knowledge.

These processes may be considered in common mathematical, social, historical and physical contexts (Dreyfus, Hershkowitz & Schwarz, B., 2003). Empirically, abstraction often can be seen in the following “epistemic actions”; these are mental actions by means of which knowledge is reconstructed:

- Recognizing,
- Building-with,
- Constructing (vertical reorganization of knowledge: methods, strategies, concepts).

These actions are observable (Pontecorvo & Girardet, 1993). They are dynamically nested in each other, may take place in parallel, and may interact (Dreyfus & Kidron, to appear).

In the last years, the model has been applied to several areas in mathematics, such as probability theory and algebra. In the area of problem solving, a catalogue of actions has been elaborated by Mitchelmore and White (2004).

## **EMPIRICAL DESIGN**

### **Participants in the study**

A total of 95 students in 31 groups of 3 or 4 (in three cases of 2) were given two small circular billiard tables with three different balls and a computer with dynamical geometry software. The students took part in a course for pre-service teacher students on the extension of the rational numbers to real numbers and their basic properties in their second year.

In order not to make things even more complicated, a problem was given for which the students should have a sufficient mathematical background. The students were in a course on calculus at the end of their second year at our University. They had all a comparable background in mathematics after courses in number theory and arithmetics, in geometry and in probability. When the videos were recorded, the students were acquainted with the following facts: The reflection law in a rectangular billiard was part of an exercise the students had to solve with dynamical geometry software two weeks before this survey started. The students know graphs of functions, the real numbers and that the rational numbers are dense in the real numbers.

### **Design of the tasks**

In order to underline the applied character of the task, two circular billiards and three billiard balls were given to the students. Since the experiments lack exactness, for instance, if the angle of incidence is too obtuse or when too many hits of the ball have to be taken into consideration, dynamical geometry software is provided as a simulation tool. Tasks A) and C) were given to encourage the construction of models that predict, describe and explain the motion of a billiard ball. Task B) is different in that a model has to be worked out which prescribes the motion of the ball on the computer screen.

However, it is part C) that provides enough challenges for the emergence of an abstraction along the following stages (Hershkowitz, Schwarz & Dreyfus, 2001):

The study presented here deals with a situation in mechanics which students can approach with the help of experiments. More precisely, the students are given two small circular billiards (of approx. 10 cm diameter made of clay and 15 cm diameter made of concrete) and three different balls. Three tasks were designed which ask the students to carry out experiments and to describe the motion of a ball on the circular billiard table:

- A) Use experiments to find paths of a ball returning to the starting point at the boundary after exactly 4 hits
- B) Use dynamical geometry software to simulate the movement of a ball which returns to the starting point at the boundary after exactly  $n = 8, 9, 10$  hits
- C) Investigate whether every trajectory of a ball returns to the starting point after finitely many hits. Assume for this that there is no friction: the ball rolls at constant speed.

The students were given exactly sixty minutes to work on these questions. During this time, they could choose to experiment with two circular billiards and three billiard balls. They also had the opportunity to work with dynamic geometry software.

### Description of video data

After working out the video transcript, their epistemic actions for the problem solving task are identified following a scheme which is described here. This is done in diagram which structures the discussions according to the epistemic actions of recognizing, building-with, and construction. The idea of summarizing the data in a diagram is realized in several articles on the nested epistemic actions model (Tabach, Hershkowitz & Schwarz, 2006).

If an action rather concerns the billiard as a problem solving task than an experiment, it is regarded as a mathematical action and classified according to the “RBC-model” as “recognition”, “building-with”, and “construction”. To distinguish the nested epistemic actions, a similar pattern is chosen to represent them. Dotted lines stand for “recognition”, small lines for “building-with” and thick lines for “construction”. For identifying the three actions, the mathematical contents of the approach are considered.

The following symbols are used to represent the corresponding actions:

Recognizing	Building-with	Construction
.....	—	—

It goes without saying that mixed forms of this appear. It is surely an interpretation to link the actions with the results. In order to improve the reliability of the classification, a list with possible mathematical contents for working with the tasks was made; during the evaluation of the video, it was completed with some details which were overseen in



the a-priori analysis. Students' considerations were classified as "recognizing" if a piece of mathematics of this list was referred to as a fact. Roughly speaking, "building-with" means that the students work with several contents of the list simultaneously and try to establish a link between them, consider it in a different context or make conjectures. A "construction" is the product of a sequence of epistemic actions which involved "recognizing" and "building-with", which lead to a construct which is new to the group. In the case of group work, this means that the construct was new for everybody in the group.

The diagrams which summarize the nature of epistemic actions follow the scale of time elapsed. This scale starts from the top of the page downwards. On the left hand side, a line indicates that an experiment was carried out. On the right hand side, the epistemic actions for the problem solving task are depicted. For this, the three different actions recognizing, building-with, and construction are shown.

Whenever the students discuss about a link between the experiments and the mathematical problem, a double sided arrow  $\leftrightarrow$  is written in the centre to show that the group relates experiment and the pure mathematics.

## FINDINGS

From the 31 groups, 23 were analysed in detail in two seminars of mathematics education together with the author. The other groups were omitted for different reasons. In some of them, there was hardly any interaction between the participants because one person dominated the discussion. Some others co-operated, but it was very hard to follow for reasons of articulation or simply because there were rather four individuals than a group.

We will present here two examples in detail because they represent two different approaches to experiments within this setting. The first diagram on the left hand side shows the case of a group with an experimental type approach. (It will be soon explained what this means.) On the very right column you see the time elapsed. In the diagram, periods when experiments are carried out can be found on the left hand side and epistemic actions in the context of problem solving on the right hand side.

To understand the diagrams better, we give short descriptions of the episodes presented here. The example on the left hand side (Figure 1 a) starts approximately in minute 18 with an action which builds up a mathematical model from a real model. In minute 20, the episode is finished with a construction in the mathematical world.

After a minute of consideration in the mathematical world, we observe a short experimental interplay at minute 23 and another one at about minute 27. Although most of the actions take place on the problem solving task, the group goes back for a moment to the experiments to verify the results they have obtained theoretically with some experiments. A striking feature is that after obtaining a "construction" on the problem solving task, the group goes back to an experiment: they want to see the theoretical result in reality and try to realize their result on the billiard table.

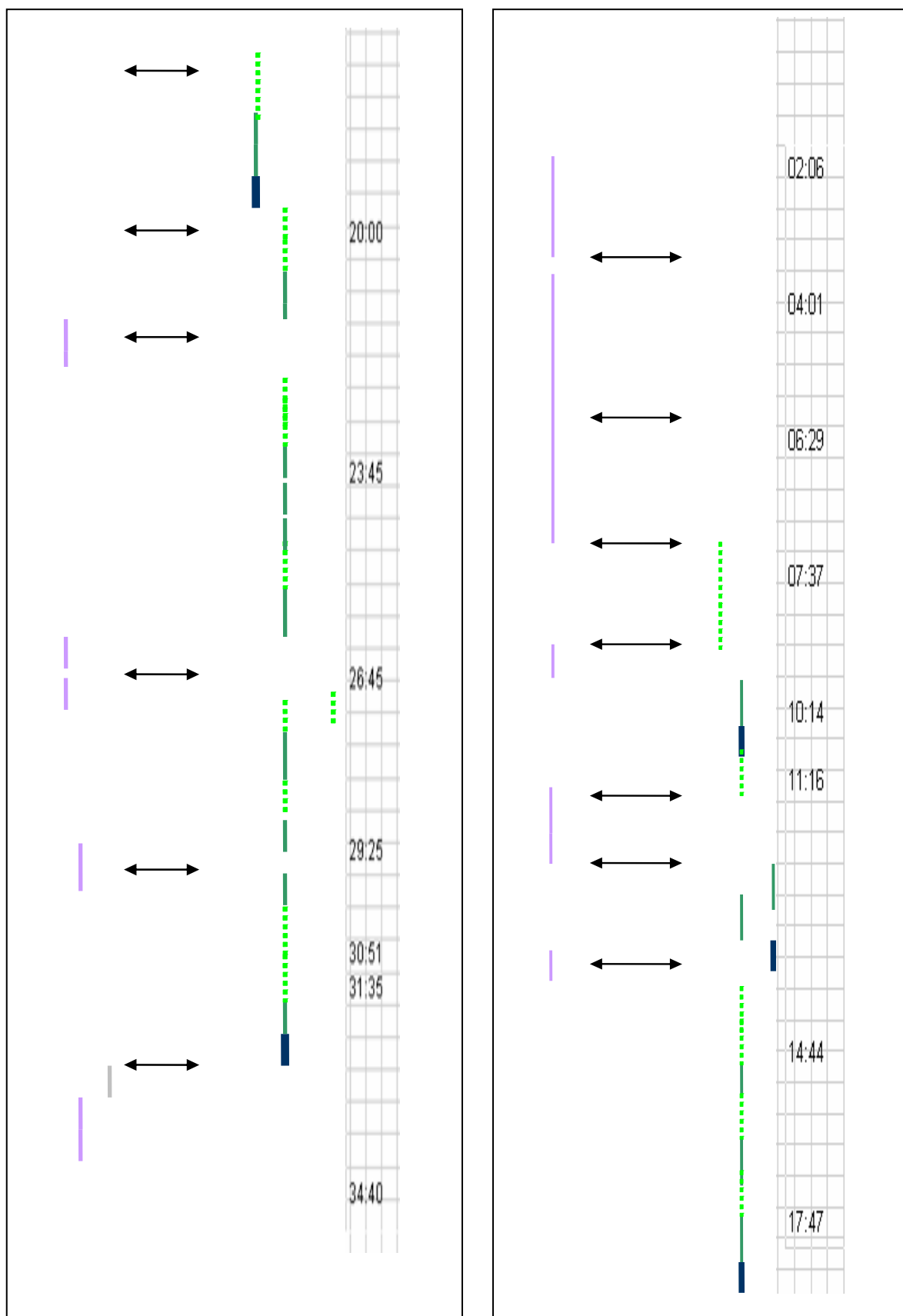

Figure 1. a) Example of experimental approach b) Example of theoretical approach.

The second diagram on the right hand side (Figure 1 b) shows a group of the theoretical approach type. They start with an experimental phase when they work at task A). In approx. the twelfth minute, you see several parallel actions.

From this point on, experiments do not play a big role for another 10 minutes. Sometimes, the participants allude to the experiments. Looking more closely at the discussions, one can see that the common experience of the first six minutes is the reason for these flashbacks. It needs a mathematical “construction” after 18 minutes to start a new experimental phase with a new problem. (This is not shown on the diagram.)

### **Two different approaches**

Among the 23 groups considered in detail, 17 could be classified to either of the following two approaches.

We talk about an experimental approach, if the following criteria are met: Longer phases with experiments of more than five minutes can be found. The understanding of experiments plays an important role in the discussions (this can be often seen by a variety of epistemic actions concerning experiments). If a building-with episode in the problem solving task is finished or if even a “construction” is obtained in the discussions of the group, experiments are repeated to verify it or just to see the some phenomena. When the group considers a problem to be solved, experiments are the reason for approaching further questions.

The theoretical approach is characterized by the following: Experimental phases last only a couple of minutes. The discussions concern primarily mathematical problems for which experiments are not very important. The main motivation is the aim of constructing knowledge in the mathematical world. For the group, “constructions” are mainly obtained in the mathematical world. It is not considered necessary to conduct experimental studies after a certain construction has been obtained. Experiments are tried again after a “construction” has been achieved and a new topic is started.

Ten groups showed a theoretical approach and seven groups an experimental approach. In six groups, mixed forms occurred, even though the theoretical approach dominates in three of them. As mixed forms, there are examples in which the role of experiments is ambiguous. For instance, sudden changes occurred if a group member suddenly brought up an aspect of experiments. In three examples, certain phases of the group work showed different types. There are indications that the different characters of the discussion originate from the fact that certain students pushed their attitude in certain phases more than others.

### **CONCLUSION**

The idea of applying the epistemic actions model of abstraction in context to a problem solving situation in a learning environment involving experiments helps structuring the problem solving process and the students’ dialogues as a whole. The importance of a “construction” for the learning process reappears in the use of experiments. In the theoretical type, the students only return to experiments after a

“construction” in the problem solving situation. In the experimental approach, the groups seem to feel a need to mirror the theoretical “construction” in an experimental setting. Both cases have in common that a “construction” is a clear cut in the organisation of the group work.

The “need” for abstraction is of importance for the motivation in the course of an epistemic action. It would be interesting to understand whether the types of groups differ in the effect of an experiment as a need for epistemic actions. Even though the different roles attributed to experiment suggest this, it would be necessary to study, for instance with the help of interviews, the motivational side of this need. Similarly, a problem which was not tackled here in the research framework is to understand how the individuals’ attitudes add to the behaviour of the group.

It is perhaps not surprising that the task is treated quite theoretically by most of the groups. But there are groups for which experiments are quite important. These groups link their epistemic actions on the problem solving side of the problem with experiments they carry out. Even though the students’ background in the first two years at the University is quite theoretical (even in the probability course), those following the experimental approach give experiments quite some importance. Still, the study might be an indication that some students feel need to approach mathematics by experiments.

The parallel analysis of epistemic actions in problem solving situations and of experiments leads to the question as to whether there could be a theory of epistemic actions in a context of mathematical modelling. This point of view will be taken at a different occasion (Halverscheid, in preparation). For example, it might be interesting to see how the decision to start an experiment might be understood as a result of an epistemic action.

## References

- Artigue, M. (1990). Obstacles as objects of comparative studies in mathematics and in physics. *Zentralblatt Didaktik der Mathematik*, 22(69), 200-203.
- Dreyfus, T.; Hershkowitz, R. & Schwarz, B. (2001). Abstraction in context: the case of peer interaction. *Cognitive Science Quarterly*. 1 (3), 307-368.
- Dreyfus, T. & Kidron, I. (to appear). Interacting parallel constructions: A solitary learner and the bifurcation diagram. *Recherches en Didactique des Mathématiques*.
- Halverscheid, S. (in preparation). *Building a Local Conceptual Framework for Epistemic Actions in a Modelling Environment with Experiments*.
- Hersh, R. (1991). Mathematics has a front and a back. *Synthese*, 88, Vol. 2.
- Mitchelmore, M. & White, P. (2004). Abstraction in mathematics and mathematics learning. *Proceedings of the 28th Conference of the International Group for the Psychology of Mathematics Education*, Vol. 3, 329–336.
- Steiner, H. G. (1990). Needed cooperation between science education and mathematics education. *Zentralblatt Didaktik der Mathematik*, 22(6), 194-197.

Tabach, M., Hershkowitz, R., & Schwarz, B. (2006). Constructing and consolidating of algebraic knowledge within dyadic processes: a case study. *Educational Studies in mathematics*, 63, 235-258.

# THE DRAGGING PROCESS IN THREE DIMENSIONAL DYNAMIC GEOMETRY ENVIRONMENTS (DGE)

Mathias Hattermann

University of Gießen

*Dynamic Geometry Environments (DGEs) in 2D are one of the well researched topics in mathematics education. They succeeded in improving and furthering mathematics class during the last years and became more and more popular in schools all over the world. Recently, DGEs for 3D-environments (Archimedes Geo3D and Cabri 3D) were designed in Germany and France. Up to now, there is a lack of studies examining 3D-environments. According to the importance of the development of spatial orientation and the utilisation of the drag-mode, this paper presents a first step to learn more about students' activities in 3D-environments. The test persons are German students who want to become school teachers and possess previous knowledge in 2D-environments.*

## THEORETICAL FRAMEWORK

During the last three decades, several 2D-Dynamic Geometry Environments (DGEs) have been created to enrich and further the learning process in the mathematics classroom. The most popular DGEs are Cabri-géomètre, GEOLOG, Geometer's Sketchpad, Geometry Inventor, Geometric Supposer and Thales. In Germany, Euklid-DynaGeo, Cinderella, GeoGebra, Geonext and Zirkel-und-Lineal are popular, with Euklid-DynaGeo being the most widespread software in German schools. DGEs are powerful tools, in which the user is able to exactly construct geometrically, discover dependencies, develop or refute conjectures or to get ideas for proofs.

DGEs are characterized by three central properties: the "drag-mode", the functionality "locus of points" and the ability to construct "macros". The drag-mode is the most important feature available in these environments, because it allows to introduce movement into static Euclidean Geometry (Sträßer, 2002). It is possible to drag basic points (points which are neither intersection points nor points with given coordinates). During this dragging process, the construction is updated, according to the construction commands which were used in the drawing. To the user, it looks as if the drawing is respecting the laws of geometry while the dragging process is in progress. With the help of the functionality "locus of points", the user is able to visualize the path of one or more points while s/he is dragging a basic point. Macros are used to condense a series of construction steps into one software command. By using "macros", the user can facilitate the control of complicated constructions, which consist of multiple construction steps.

2D-DGEs are one of the best researched topics in mathematics education and especially within the PME-group (Laborde et al., 2006). For example, we find research on "DGE and the move from the spatial to the theoretical" (Arzarello et al., 1998,

2002) or” “construction tasks” (Soury-Lavergne, 1998). Noss (1994) has shown that beginners have problems to construct drawings, which are resistant to the drag-mode and it is reported that for pupils there exist two separate worlds, the theoretical one and the world of the computer. ”The notion of dependency and functional relationship” (Hoyles, 1998 and Jones, 1996) is another interesting theme and it has been shown that pupils have heavy problems in understanding the notion of dependency. They have to be encouraged to use the drag-mode to support the understanding of the spatial-graphical and the theoretical level, serving as a tool for externalizing the notion of dependency. Several researchers showed that students do not use the drag-mode spontaneously and they have to be encouraged to do it. Most of the students are afraid to destroy the construction by using the drag-mode and they do not like to use the drag-mode on a wide zone (Rolet, 1996 and Sinclair, 2003). Arzarello and his group elaborated a hierarchy of several dragging modalities, which were linked to ”ascending” and ”descending” processes and reveal students’ cognitive shifts from the perceptual level to the theoretical one (Arzarello, 1998, 2002 & Olivero, 2002). There is a great variety and number of research reports concerning the use of the drag-mode in proving and justifying processes (for example Jones 2000 and Mariotti 2000). Other fields of study were ”the design of tasks” (Laborde 2001), ”the role of feedback” (Hadas, 2000) and ”the use of geometry technology by teachers” (Noss, Hoyles, 1996).

## **STUDY DESIGN**

The results of the studies mentioned before were based on 2D-DGEs, so the idea of the study was to get first results about the dragging process in 3D-environments. At present, two 3D-DGEs exist, namely Archimedes Geo3D, which is developed by Andreas Goebel and Cabri 3D, which is developed by Jean-Marie Laborde. A first question, which soon comes up, is the following: ”Is it possible to transfer the research results found in 2D-environments to 3D-environments?” At least it seems unclear to answer the question positively, because significant differences exist between the 2D- and the 3D-case: In 2D-environments, the user has a complete variability on the screen by using his mouse. This is no more valid in the 3D-case, because in these environments the user has only a restricted variability. S/He can only move the cursor on a plane, because his input medium (the mouse) acts on a desktop, which is obviously 2D. To move the cursor ”in the whole space”, the user has to act differently, e.g. to push a key on the keyboard to reach for example points on a straight-line perpendicular to the plane in which the cursor was moved before. However, these movements in 3D-space were implemented differently in the two programs.

## **Research questions**

The main interest was to find first results concerning students’ behaviour during a solution process in 3D-environments (Archimedes Geo 3D or Cabri 3D) and the usage of the drag-mode in it. Do students even use the software-environment if they have other possibilities as paper and pencil and a material model to work with? Do students use the drag-mode at all? How do students validate their solutions?

Participants with previous knowledge in 2D-environments were chosen because it is conjecturable that pupils in school will work with 2D-programs first. The idea of task one (constructing a cube) was to get the probands familiar with the specific DGE and to create an environment to work. The idea of task two, which is the most important one, was to diagnose students' preferred tools (paper and pencil, real model, DGE) during the solution process and the observation of the usage of the drag-mode.

### **Participants**

The study took place in July 2007 at the University of Gießen. 15 Students between the fifth and the seventh semester, who want to become schoolteachers, participated in the study. The students had precognitions concerning 2D-DGEs, because they had to attend a lecture, which was called "Computers in class". During these lectures they worked with Euklid-DynaGeo and they passed an exam in which they had to solve tasks in DGEs, Computer Algebra Systems (CAS) and with the help of spreadsheets. Furthermore the students attended a seminar on "conic sections" and during a session of 90 minutes they worked with Cabri 3D to analyse the possible sections between a cone and a plane to find circle, ellipse, hyperbola and parabola. They constructed a cone in Cabri 3D and they defined a plane to observe the different sections. Two students, who were responsible for the session, helped the others if problems occurred. The students had never before used Archimedes Geo3D. There were seven groups (six groups of two students and one group of three students) and three groups worked with Archimedes Geo3D while four groups solved the given tasks with the help of Cabri 3D. Each group worked in a separate room, the actions on the screen were recorded utilising the screen-recording software "Camtasia". Furthermore, a webcam and a microphone were used to record the students' voices and interactions.

### **Task one**

The first task was to construct a cube in the particular DGE without using the existing macros to construct cubes. The students should become familiar with the particular DGE during the solution process of task one. Furthermore, I was interested, if the students were able to use spatial constructions to solve the problem. For example, I wanted to know if they used circles or constructions that were known to them from planar geometry or if they use for example spheres to construct points. Another interesting point was, if they use transformations like reflections or rotations during the solution process. I have to mention that they were not introduced in handling rotations and reflections. If they wanted to use these features, they had to learn it with the online-help. Moreover, it was interesting if students use the drag-mode to validate their construction.

### **Task two**

The students had the possibilities to use paper and pencil, to use the software, to work with a real model or to utilise their imagination to solve the second task. Furthermore, the given problem should help to find out if it is possible for the students to use the drag-mode in 3D-environments, the usage of the DGE assumed. Task two was the



following: "A student affirms: The slice plane between a cube and a plane can be: a) an equilateral triangle, b) an isosceles triangle, c) a right-angled isosceles triangle, d) a regular hexagon. Construct with the help of the function "cube" a cube, check the student's affirmations and justify your results." The question was what approach do the students prefer? Do they use paper and pencil to solve the problem? Do they try to imagine the intersection between cube and plane without any support or are they able to negotiate their experience in 2D-environments to 3D-ones? Do they use the drag-mode to solve the task and how do they use it? It has to be mentioned that students do not have to use the drag-mode at all and if they decided to do it, there are different possibilities to use it. It is possible to define the plane with the help of three arbitrary points in space. This possibility is difficult, because a controlled dragging of the plane is not possible when the points, which define the plane, are not linked to an object. On the other side, it is quite simple to define three points on three appropriate segments of the cube to define the plane, because afterwards, the user is able to do fully controlled dragging.

## **RESULTS**

### **Task one**

Seven groups tried to solve the two tasks, while five groups succeeded in constructing the cube. It has to be mentioned that one group, which could not construct the cube worked with a very slow computer, so it was nearly impossible for them to succeed. So, five of six groups succeeded. It is interesting that the groups, which worked with Archimedes Geo3D, needed between 40 and 50 minutes to construct the cube, whereas the two Cabri-groups could do with 15 and 28 minutes. The fastest group was responsible for the realisation of the session "conic sections" and therefore had advanced experiences in handling Cabri 3D. Another interesting point is that two of the five groups which succeeded used spatial operations - concretely spheres to construct corners of the cube. The other three groups preferred circles to measure equidistant distances. Two groups tried to work with rotations, but they did not succeed in using it. Another point worth mentioning is the verifying of the construction. It could be observed that only two of the five groups tried to verify their cube construction. The first group measured nearly all segments of the cube, whereas the most experienced group used the drag-mode to validate. Two other groups were encouraged to use the drag-mode to check their construction and there was a hesitation in it, as it was observed by pupils in school in 2D-environments.

### **Task two**

The solving process of task 2 is quite different from the first task, because in this case I was interested if the problems could be solved, what tools were used during the solution process and what usage of the drag-mode was utilised? First of all, every group found the equilateral triangle and the isosceles triangle. The right-angled isosceles triangle (which does not exist as an intersection between a cube and a plane) and the regular hexagon (which does exist) caused greater problems. Two groups had

the conjecture that the right-angled isosceles triangle does not exist, but they could not justify their assumption. One group was able to justify the inexistence, whereas one group did not answer that question. Three groups maintained that a right-angled isosceles triangle exists and two of these groups used the feature "measuring" in Cabri to validate their assumption. The problem is that Cabri shows a  $90^\circ$ -angle although this angle is less than  $90^\circ$ , which is a consequence of the mathematical modelling. There were interesting discussions in the group, but at the end the authority of the computer won and the test persons decided in favor of the existence of the right-angled isosceles triangle. Two groups found the regular hexagon and one group was able to find it with a hint. Two groups maintained that the regular hexagon does not exist, whereas one group did not answer that question.

Another remarkable point is the usage of the real cube model. Every group tried to find validations for their conjectures with the help of the real model, the utilisation of the real model prevailed the using of the computer definitely. I could find out that the students did not use the drag-mode in an expected manner, they preferred "the old strategy" to examine the cube and to try to imagine the intersection. The software was used to validate the conjectures, which were mostly generated outside the software environment. In this case, students defined a plane with the help of three base points, so that the plane could not be dragged. Sometimes students utilised the figure on the screen as a "real model" and in order to work in the computer environment, they tried to imagine the intersection by handling with a sheet of white paper before the screen to represent the plane.

Furthermore, it could be stated that the drag-mode was not understood and it is not sure, if these students did not understand it in the 2D-case or if they could not negotiate it to the 3D-environments. An evidence for this result shows the approach of one group to find different intersections. The students defined many base points on every segment of the cube and defined a plane with the help of three points. After verification, they deleted the plane and constructed another one with the help of three other points. Sometimes different groups used the drag-mode, but only in exceptional cases in a manner that a controlled dragging of the plane was possible. The most experienced group tried to use the drag-mode, but they used three arbitrary points in space to define the plane and because of uncontrolled dragging, they were disappointed and at the end de-motivated.

Students sometimes generated an idea while they were working with the software, but afterwards they discussed the problem in further detail at the real model. As in the first task, students had problems to justify their results. Every group was able to find the equilateral triangle and the isosceles triangle, but only two groups gave correct justifications with the help of the Pythagorean Theorem or general statements, for example that the diagonals of same squares have the same length.

In the following, I would like to report some students' statements: "I do not know, I do not have enough imagination to solve the task.", "We can not drag the plane,

because we have to use base points to define the plane.” ”Is there a feature which can help us to move the plane?” The first quotation shows that the student forces himself to imagine the figure; he does not see the possibility to solve the task with the help of the special software environment. The following quotations explain the inability to understand and use the drag-mode, the student has the desire to move the plane to scrutinize several figures, but he is unable to do it, because he does not possess sufficient competence with this instrument.

## CONCLUSION

Concerning task one, an idea to explain the different speed of construction is the existing base plane (the x-y-plane) in Cabri 3D, which facilitates the construction, because the students can use the base plane as a base area for the cube. In Archimedes Geo3D they have to construct such a plane, which is quite easy by using a given macro, to use it for the base area of the cube.

In task two, it has been shown that despite of the previous knowledge concerning 2D-DGEs; students do not use the drag-mode in 3D-environments without any instruction. This result is comparable with the results obtained by Rolet (1996) and Sinclair (2003) and it seems as if students have to be encouraged and be instructed to use the drag-mode. Experiences in 2D-environments seem to be insufficient to work in 3D-space. In general, students seem to have big problems in justifying simple facts in 3D-environments, for example with the intersection resulting or not in an equilateral triangle. In addition to this, there seems to be a tendency to prefer the real model to solve the given task. Why is this the case? Because students do not know the advantages of the software? Because they are not familiar enough with the software? Because they are used to the solution process ”take a real model and try to imagine” from school and university? Because the real model is touchable?

After the analysis of the available data, I would claim that tasks, which seem easy to the students, were solved by imagination and were verified with the help of the software. In this case a plane is constructed by three base points and no dragging is needed, because the students want to check their idea. If the task is more difficult for the students, they try to get an idea by working with the real model.

Furthermore, the most experienced group has to be examined differently, because they had much more previous knowledge. This group tried to solve the second task with the help of the drag-mode. Something like a ”scheme” as it is described in Rabardel (1995) exists. The students used the drag-mode, as they did it during the session ”conic sections”, but they could not adapt their scheme to the new task. To find ellipse, hyperbola and parabola it was sufficient to drag the section plane arbitrarily, but to scrutinize the different section figures of a plane and a cube, more precision is demanded. The group tried to find results applying the ”old scheme”, which was insufficient, but the adaptation of the ”old scheme” to the new task did not take place.

It has been shown that the observation of dragging modalities and utilisation schemes concerning the drag-mode in 3D-environments demand more preparatory work. First

of all, the participants have to become more familiar with the special DGE and they have to appreciate the advantages of the DGEs. Forcing probands into this DGE by prohibiting paper and pencil environments and real models may be a method. The usage of crucial features as transformations and especially the drag-mode will have to be repeated during one or two sessions before the study. During these preparation sessions some tasks concerning black boxes (in the French community: the "boîtes noires", centre informatique pédagogie 1996) should force students to use the drag-mode. The question concerning task two could be modified in the following way: "Find all existing section figures of a cube and a plane." This could be a way to foster the need of using the drag-mode.

It remains questionable if there should be neither a real model of a cube nor paper and pencil for utilisation. This may be a way of forcing the students into the software environment to find results concerning the handling of the drag-mode and to develop appropriate utilisation schemes. On the other hand, it would be important to compare the use of the three tools (DGE, paper and pencil, real model) with probands who are more conscious of the advantages of 3D-DGEs, e.g. as the visualisation of several section figures in short time intervals with the help of the drag-mode and the definition of planes by flexible points.

## References

- Arzarello, F., Micheletti, C., Olivero, F., & Robutti, O. (1998). Dragging in Cabri and Modalities of Transition from Conjectures to Proofs in Geometry. In A.Olivier, K. Newstead (Eds.), *Proceedings of the 22<sup>nd</sup> Psychology for Mathematics Education International Conference* (Vol.2, pp. 32-39). South Africa: Stellenbosch.
- Arzarello, F., Olivero, F., Paola, D., & Robutti, O. (2002). A cognitive analysis of dragging practices in Cabri environments. *Zentralblatt für Didaktik der Mathematik*, 34(3), 66-72.
- Centre Informatique Pédagogique (CIP) (1996). Apprivoiser la géométrie avec CABRI-GÉOMÈTRE (pp. 139-208). Genf, Suisse: Centre informatique pédagogique.
- Hadas, N., Hershkowitz, R., & Schwarz, B. (2000). The role of contradiction and uncertainty in promoting the need to prove in dynamic geometry environments. *Educational studies in Mathematics*, 44(1-3), 127-150.
- Hoyles, C. (1998). A culture of proving in school mathematics. In D. Tinsley & D. Johnson (Eds.), *Information and Communication Technologies in School Mathematics* (pp. 169-181). London: Chapman and Hall.
- Jones, K. (1996). Coming to know about dependency within a dynamic geometry environment. In L. Puig & A. Gutierrez (Eds.), *Proceedings of the 24<sup>th</sup> Conference of the International Group for the Psychology of Mathematics Education* (Vol.3, pp. 145-151). Spain: University of Valencia.
- Jones, K. (2000). Providing a foundation for deductive reasoning: student's interpretations when using dynamic geometry software and their evolving mathematical explanations. *Educational studies in Mathematics*, 44(1-3), 55-85.

- Laborde, C. (2001). Integration of technology in the design of geometry tasks with cabri-geometry. *International Journal of Computers for Mathematical Learning*, 6, 283-317.
- Laborde, C., Kynigos, C., Hollebrands, K., & Strässer, R. (2006). Teaching and Learning Geometry with Technology. In A. Gutierrez & P. Boero (Eds.), *Handbook of Research on the Psychology of Mathematics Education* (pp. 275-304). Rotterdam: Sense.
- Mariotti, M.A. (2000). Introduction to proof: the mediation of a dynamic software environment. *Educational Studies in Mathematics*, 44(1-3), 25-53.
- Noss, R., Hoyles, C., Healy, L., & Hoelzl, R. (1994). Constructing meanings for constructing: An exploratory study with Cabri-geometry. In J. da Ponte, J. Matos, & J. Filipe, (Eds.), *Proceedings of the 18<sup>th</sup> Conference of the International Group for the Psychology of Mathematics Education* (Vol.3, pp. 360-367). Lisbon, Portugal: University of Lisbon.
- Noss, R. & Hoyles, C. (1996). *Windows on Mathematical Meanings*. Dordrecht, The Netherlands: Kluwer Academic Publishers.
- Olivero, F. (2002). *The Proving Process within a Dynamic Geometry Environment* (PhD thesis). Bristol, UK: University of Bristol, Graduate School of Education.
- Rabardel, P. (1995). *Les Hommes et la Technologie. Approche Cognitive des Instruments Contemporains*. Paris: Armand Colin. Translation to English (retrieved on 7.1.2008) at [http://ergoserv.psy.univ-paris8.fr/Site/default.asp?Act\\_group=1](http://ergoserv.psy.univ-paris8.fr/Site/default.asp?Act_group=1)
- Rolet, C. (1996). *Dessin et Figure en Géométrie: Analyse et Conceptions de Future Enseignants dans le Contexte Cabri-géomètre*. (unpublished doctoral dissertation, University of Lyon1). Lyon, France.
- Sinclair, M. (2003). Some implications of the results of a case study for the design of pre-constructed dynamic geometry sketches and accompanying materials. *Educational Studies in Mathematics*, 52(3), 289-317.
- Soury-Lavergne S. (1998). *Étayage et Explication dans le Préceptorat Distant, le Cas de TéléCabri* (unpublished doctoral dissertation of University Joseph Fourier). Grenoble, France.
- Sträßer, R. (2002). Research on Dynamic Geometry Software (DGS) - an introduction. *Zentralblatt für Didaktik der Mathematik*, 34(3), 65.

# THE ROLE OF GESTURES IN THE MATHEMATICAL PRACTICES OF BLIND LEARNERS

Lulu Healy

Solange Hassan Ahmad Ali Fernandes

Universidade Bandeirante de São Paulo

Colégio Nossa Senhora do Rosário

*Our research aims to explore the mathematical practices of blind learners. To contribute to the overarching question of how our physical senses mediate our interpretation of mathematical phenomena, we seek to identify how learners without access to the visual field make use of the various resources in learning settings, both physical and semiotic, to negotiate mathematical meanings. In this paper, we concentrate our analyses on the mathematical practices of one student, blind since birth, as he attempts to make sense of activities involving perimeter, area and volume. We consider in particular the role of his gestures, not only in the dialogues established with others, but also in structuring his own mathematical ideas.*

## INTRODUCTION AND BACKGROUND

On the 7th of July of 1688, William Molyneux sent a letter to John Locke in which he proposed a question that caught the interest of various philosophers of the time and continues to generate discussion until today. The question raised by Molyneux was whether a person, born blind, who had learned to distinguish between a sphere and a cube through touch, would be able to correctly identify these solids by visual means if he or she gained to capacity to see (Riskin, 2002). Not surprisingly, positions were divided as to the correct response to this question, with the different responses reflecting the different values attributed to experiences originating in the senses and perception, and the influence of the body on cognition. Given the particularity of the subjects involved in our research, blind school students, we have a special interest in this relationship.

A more radical version of Molyneux's question was considered by Condillac, who elaborated a sensualist theory of knowledge in the work *Treatise on Sensations* published in 1754 (Condillac & Degérando, 1989). By simulating the process of humanisation of a marble statue, he considers what this being would come to know if each of the senses were to be acquired in isolation from the others, or in combination with one or two others. In this way, he presents his thesis that all knowledge evolves from the transformation of sensations, or from what we could call perceptions.

Amongst the various philosophical perspectives which discuss the relationship between perception and knowledge, phenomenological theorists argue that perception is primary in human knowledge. For phenomenologists, there is no difference between sensation and perception, because there is no such thing as a partial or elementary sensation (Chauí, 2000) - we see and we perceive forms, that is, structured totalities seeped in sense and in meaning. In this way, perception, or perhaps better, the perceptual field, is key in the complex relations between our bodies and our world, or

rather, between the subject and the objects in a field of visual, tactile, olfactory, gustatory, auditory, spatial, motor and linguistic meanings (ibid.). If phenomenologists are agreed on the cognitive function of bodily activity, one divergence which distinguishes between the positions of two influential thinkers, Husserl and Merleau Ponty, relates to the importance of the sociocultural. The position adopted by Merleau Ponty is that “senses grouped by the same name are experienced in distinct and even contrasting manners by people from different cultures” (Furlan & Bocchi, 2003). What attracts us in this perspective is the recognition of the influence of sociocultural factors in the constitution of semiotic signs and systems.

Turning more specifically to mathematics education, Nemirovsky and Ferrara (2005) also emphasise the cognitive importance of the body in mathematical thinking. For them, understanding of a mathematical object is intrinsically linked to the ways in which the tasks given to learners motivate different areas of perception, stimulating changes in states of attention, conscience and emotion which bring a perceptual-motor character to mathematical understanding and thinking (Nemirovsky, 2003). It should be clear by now that, like them (and many others), we do not think of cognition as something confined to cerebral activity and that we believe it is not possible to disassociate experience and perception from cognitive activity.

As we posit a centrality to bodily experiences in cognition and accept that physical senses play an important role in interpreting mathematical phenomena, an interesting question is how those without access to particular senses interpret the behaviour of mathematical objects. If we can identify the differences and similarities in the mathematical practices of those whose knowledge of the world is mediated through different channels, perhaps we can gain more robust understanding of the relationships between experience and cognition more generally. The blindness, or the absence of a particular sense, of the learners with whom we are working leads us to concentrate our attention on *tactile practices* - touch being a sense rather neglected in studies of mathematics learning - and *semiotic practices* - such as spoken language, Braille, diagrams, graphs, gestures for example. Together, it is through touch and through such semiotic practices that blind learners express and reveal their ideas, intentions and emotions.

We know that there are some differences in the ways that blind learners process data when compared with sighted students. When exploring an object, for example, the hands of the blind learner, like the eyes of the sighted, although in a slower and successive form, are moved in an intentional manner, catching particularities of the form in order to perceive - and at the same time conceive - the object. Touch permits a gradual analysis, from parts to the whole, whereas vision is synthetic and global. The partial information supplied by touch has a sequential character and must be integrated, constructed into a coherent whole. One question, then, is the extent to which this form of exploration highlights particular mathematical relationships and properties or particular ways of thinking about mathematical objects. A second question relates to language, or more precisely, the role of gesture in language.

Recent research in mathematics education and beyond (see, for example, Nemirovsky, Roth, McNeill, Iverson, & Goldin-Meadow) has considered the potential - both communicative and cognitive - of the spontaneous movements of the body, hand gestures, noddings of the head, changing of postures and the like, which accompany discourse. But what of blind learners who cannot see the gestures of others (or, being the case, their own)? Are gestures really important for all in mathematics learning?

In the rest of this article, we concentrate on this question, exploring the role of gestures in the discursive practices of a blind learner when the objects of study are volume, area and perimeter. Returning to the phenomenological perspective of Merleau Ponty, in which knowledge comes from experiences with the body through its existence in a world which is temporal and spatial, it is important to take account of the context in which the interactions we analyse occurred. The discursive practices used by the learners and researchers, including their use of gestures, were enacted with the intention and belief that they are shared means of discussing school experiences contextualized by the cultural instruments related to the same. The particularities of the gestures presented in the text that follows are shaped, not only by the specific characteristics of the learners, but also by the mediational systems (the material tools and discourses), detailed in the next section, that permeate the instructional scenario.

## **THE RESEARCH CONTEXT**

During twenty-seven months, we worked, in collaboration with a group of five school teachers, on a research project aiming to investigate the processes by which blind learning appropriate mathematical knowledge and to design learning situations conducive to these processes<sup>1</sup>. The project took place in a school from the public school system of the state of São Paulo in Brazil, with a long history of including learners with visual impairments. During the project, a total of twelve blind or partially sighted students participated in the various empirical activities. The study of volume, area and perimeter considered in this paper occurred over four research sessions, each of approximately 90 minutes. Four students, all congenitally blind, and two researchers took part in these sessions. In the first two sessions, the activities centred on the area and perimeter of plane figures (starting with quadrilaterals), the third initiated work on volume and in the final session, the students worked on a task which involved determining the most economical amongst a range of boxes and other rectangular prisms. All the sessions were video recorded. Three different material tools were elaborated for the activities, all of which were intended to favour tactile exploration. The way in which the tasks were proposed and the organisation of the students aimed to stimulate dialogues between the participants, between the researchers and individual learners, between pairs of learners and between all participants (four learners and two researchers). The choices related to task design were consistent with Nemirovsky's views on perceptual-motor activity in that we

---

<sup>1</sup> We are grateful for the research grant from FAPESP (No. 2004/15109-9) which supported this project.



sought to activate two perceptive channels of the learners - audition and touch and to incite the communication of their perceptions by means of speech and gestures.

For this article, we have selected, transcribed and codified episodes from the first research session to show how one of the students, Leandro (14 years olds) made use of the semiotic resources of the learning scenarios to create mathematical meanings which then mediated his practices in the latter sessions. In our analyses, we seek to illuminate and understand the role of gestures as both instruments for communication and cognition. With this in mind, we applied the classification of gestures proposed by McNeill (1992):

*Iconic gestures* (♦) have a direct relation with the semantic discourse, that is, there exists an isomorphism between the gesture and the entity it expresses. However, comprehension of the iconic gesture is subordinated to the discourse which accompanies it.

*Metaphoric gestures* (●) indicate a pictorial representation of an abstract idea which cannot be represented physically, for example, when we illustrate with hand movements the limit of a function  $f(x)$  when  $x$  tends to zero.

*Deitic gestures* (♣) have the function of indicating objects (real or virtual) people and positions in space.

*Beat Gestures* (♪) are short and rapid and accompany the rhythm of the discourse giving special meaning to a word, not due to the object that it represents but to its role in the discourse.

Our work and our analyses are very much at the exploratory stage - as there are currently very few studies which discuss the role of gestures in instructional scenarios composed of blind participants from which we can draw. Goldin-Meadow (2003) and Iverson and Goldin-Meadow (1998) suggest that blind individuals make as much use of gestures as the sighted, at least as far as beat, deitic and iconic gestures are concerned, using this as evidence to support their cognitive as well as communicative function. Our objective however is not only to classify gestures, but to understand how, in concert with other resources within instructional settings, they become tools for creating and communicating mathematical meanings.

### **Creating a gesture to represent area**

Since the mathematical concepts under study during the research sessions are concepts usually developed in elementary as well as high school mathematics curricula, at the beginning of the first session, we asked Leandro to describe his knowledge about area and perimeter. He offered the following definitions: "*Perimeter is all sides. It's the border of the figure. Area is the internal space*" At this point, his discourse was not accompanied by any gestures. Leandro's description suggests a certain familiarity with the mathematical terms, however, it seemed at the beginning of the task that his expressions were echoes of the voices of others from previous activities and when Leandro was given a board with impressions of four

rectangles (two of which were filled with unit cubes as shown in Figure 1), he was not able to determine either perimeter or area. Indeed, Leandro, along with the other students, explained that it was very rare for them to interact with representations of geometrical shapes, usually they were given the measures along with an appropriate procedure - their task was to calculate a numerical result.

Following an intervention from the researcher who indicated the perimeter of a rectangle (measuring 8cm by 3cm), by tracing Leandro's hand over the edges of the form and the area by passing his hand over the cubes that filled the shape (Leandro is the student in the orange jumper in the left of the figures which follow), he quickly determined that the sum of the four sides was 22, but was still not sure about the area:



Figure 1. Adding the sides.



Figure 2. "Eight, eight, eight".

Leandro: *The perimeter of my figure is 22. It's this, all this from here, isn't it?* (♣) (He retraces his fingers around the sides he has added, a deitic gesture intended to enable the sighted researcher to see that he had appropriated her strategy)

Res: *And the area?*

Leandro: *I don't know.*

Once again the researcher took Leandro's hand and moved it over the internal space of the rectangle, this time repeating the words originally offered by him. After some exploration, Leandro uses a beat gesture to indicate he has arrived at the solution:

Leandro: *So, my figure has 24.* (♩) (Beats one of his hands twice on the figure)

Res: *And why do you think it is 24?*

Leandro: *Because it has 24 little squares here* (♣) (Places his hand on the figure).

Res: *And how did you work it out?*

Leandro: *I did 8, 8, 8, gave 24* (♦) (Traces his hand from left to right over each row of eight cubes which compose the area of the rectangle).

We have classified Leandro's last gesture as iconic and not deitic since the actions of his hands accompanying his speech not only indicate the objects in question but also simultaneously compose the area being measured. This gesture turned out to be central to the rest of his activities - not only for area but also for volume. As we were hoping that the students would elaborate methods, meaningful for them but also with a general applicability, the next task given to Leandro was to calculate the measures for a rectangle of 8cm by 5cm. This time, he did not have access to any external

concrete representation of the figure although did still have access to the wooden centimetre cubes.

Leandro rapidly calculated the perimeter of the rectangle, again making use of an iconic gesture in which he traced the perimeter over the imaginary sides of the rectangle on the table in front of him (Figure 3). Clearly, although he could not see it, this gesture was directed at himself, perhaps the sighted learner would have drawn a rectangle at this point, but sketching a figure is a difficult option for the blind learner and, for this task at any rate, the physical activity of tracing out the generic rectangle was sufficient for Leandro to perceive its perimeter.



Figure 3. Calculating perimeter (♦).



Figure 4. Hands as rectangle (♦).

Once again, Leandro found the calculation of the rectangle's area more demanding. Given his apparent difficulty, the researcher suggested he explained his thinking:

Leandro: *I am thinking, if I do 8 here and 5 here (♦) (positioning his hands as shown in Figure 4). Then I could...*



Figure 5. An external. gn.

method, which involves decomposing the figure into rows.

Leandro: *I made a little line with eight and one with five (♣) (places his hand on the L-shape), so the perimeter is 26. For the area, we need to complete. I made as if I was completing it. I did eight times five (♦) (traces on the table five imaginary lines of eight cubes) which gives 40.*

From this point onwards, over the rest of the four research sessions, Leandro consistently used the gesture of tracing imaginary lines (in the air or on a surface) when he talked, or as he thought, about area. Clearly this gesture for area was

strongly shaped by the material tools made available during the first research session, as well as by the initial interventions of the researchers. In the third session, when he began to work with volume, he generalised this gesture: instead of tracing imaginary lines with one finger he moved his whole hand as if creating a series of layers to compose the volume of a three dimensional shape.

## **REFLECTIONS ON OUR ANALYSES**

What we have tried to illuminate in our analyses is how the blind learner is able to create a sign which represents his physical experience, his perception of a mathematical object, by coordinating the various resources available in the learning setting. In this short example, we have focussed mainly on the interactions of one blind learner with a sighted researcher. Leandro knew the researcher could see his gestures, but he also made gestures to himself, a strong indication of the cognitive importance of this physical activity. Indeed, our data indicates that when communicating with other blind learners, Leandro continued to use gestures, pointing at objects and making hand movements, that neither he nor his partner could see to structure his own thinking. On some occasions, he would subsequently take the hand of his partner and re-enact his gestures so that they could be both communicated and physically experienced by another blind learner.

Our analyses thus far convince us that gestures are as much a part of blind learners' mathematical practice as of the sighted. Indeed, iconic gestures, such as those developed by Leandro, may actually be more important to the blind, since we suspect that a sighted learner may have chosen to sketch the generic rectangle, rather than gesture it. In the example presented in this paper, metaphorical gestures did not appear to play a part in the problem solution. Since Goldin-Meadow (2003) has also alluded to a relative absence of metaphoric gestures amongst blind individuals in her studies, this is a finding that merits further exploration. However, the favouring of iconic gestures in Leandro's practices in these activities may be related to the concept under study - area is something relatively straightforward to represent physically - and may also be related to the specifics of structuring of the task and materials with which he was working. And this brings us to another important question for exploration. To date, the learning settings we have investigated have involved adaptations of situations originally planned for sighted learners. Inevitably, these learning situations were designed on the basis of what we know of the learning trajectories of sighted learners. It may be that the gradual processing of data that results from tactile as opposed to visual exploration makes possible rather different trajectories to mathematical knowledge that we are not yet exploiting - and that may help in the design of new learning situations that contribute to changing the mathematical experiences of a variety of learners and which respect the diversity and potential of different forms of accessing mathematics.

## **Referencias**

Chauí, M. (2000). *Convite a Filosofia*. São Paulo: Ática.

- Condillac, E. B. & Degérando, J. (1989). *Textos Escolhidos*. Tradução: Luis Roberto Monzani (et al.). São Paulo: Nova Cultura, Os Pensadores.
- Furlan, R. & Bocchi, J. C. (2003). O corpo como expressão e linguagem em Merleau-Ponty. *Estudos de Psicologia*, 8(3), 445-450.
- Goldin-Meadow, S. (2003). *Hearing Gestures: How Our Hands Help us Think*. Cambridge, MA: Harvard University Press.
- Iverson, J. M. & Goldin-Meadow, S. (1998). *Why People Gesture when they Speak*. London. Macmillan Publishers Ltd. Nature, vol. 396. 19 nov.
- McNeill, D. (1992). *Hand and Mind: What Gestures Reveal about Thought*. Chicago: University of Chicago Press.
- Nemirovsky, R. (2003). Three conjectures concerning the relationship between body activity and understanding mathematics. In: N.A. Pateman, B.J. Dougherty, & J.T. Zilliox (Eds.), *Proceedings of PME 27*, 1, 103-135.
- Nemirovsky, R. & Ferrara F. (2005). Connecting talk, gestures, and eye motion for the microanalysis of mathematics learning. *Proceedings of PME29*. Vol. 1, p. 138-143.
- Roth, W. M. (2001). Gestures: Their role in teaching and learning. *Review of Educational Research*, 71, 365-392.
- Riskin, J. (2002). *Science in the Age of Sensibility: The Sentimental Empiricists of the French Enlightenment*, Chicago and London: The University of Chicago Press.

# **INFORMAL STRATEGY USE FOR ADDITION AND SUBTRACTION OF THREE-DIGIT NUMBERS: ACCURACY AND ADAPTIVITY OF GERMAN 3<sup>RD</sup>-GRADERS**

Aiso Heinze

University of Regensburg

Frank Lipowsky

University of Kassel

*Informal mental computation strategies are considered as an important content of primary mathematics classroom to deepen the conceptual knowledge on numbers and the understanding of arithmetic. However, empirical findings indicate that many students do not achieve the goal of an adaptive use of strategies for computations with multi-digit numbers. In a study with German 3<sup>rd</sup> graders (N = 245) we investigate accuracy and adaptivity of students' strategy use when adding and subtracting three-digit numbers. The results indicate that students often choose efficient strategies provided they know appropriate strategies for a given problem. We hypothesize that students' strategic competencies depend on the teaching approach to informal mental computation strategies*

## **INTRODUCTION**

In the last 15 years mathematics educators in many countries supported a reform approach for the elementary arithmetic education: the leading role of the standard (written) algorithms for the basic arithmetic operations was questioned. Besides the acquisition of this routine expertise in many curriculums and/or standards in different countries the acquisition of adaptive expertise, i.e. the ability of individuals to solve arithmetic computation tasks flexibly with a diversity of different strategy, was attached great importance (e.g., van den Heuvel-Panhuizen, 2001). The adaptive use of computation strategies is seen as an important way to foster students' conceptual knowledge on numbers.

Although there is a broad consensus among researchers on the importance of an adaptive strategy use for multi-digit computations, empirical results show that the students' competencies does not fit these standards (e.g., Selter, 2001; Torbeyns, Verschaffel, & Ghesquière, 2006). Moreover, there are only few empirical studies for the question which kind of instructional approach is helpful to develop and/or foster students' strategic competence.

## **INFORMAL COMPUTATION STRATEGIES**

In the international literature we find different categorizations of strategies for multi-digit addition and subtraction problems (e.g., Threlfall, 2002). Our research is based on a categorization of five idealized strategies that are well known in German arithmetic education literature; four of them are suitable for addition and subtraction, one only for subtraction (cf. Table 1). Obviously, children use more strategies which sometimes combine two or sometimes three of the idealized strategies.

Jump strategy	Split strategy	Compensation strategy	Simplifying strategy	Indirect addition
$123 + 456 = 579$	$123 + 456 = 579$	$527 + 398 = 925$	$527 + 398 = 925$	$701 - 698 = 3$
$123 + 400 = 523$	$100 + 400 = 500$	$527 + 400 = 927$	$525 + 400 = 925$	$698 + 3 = 701$
$523 + 50 = 573$	$20 + 50 = 70$	$927 - 2 = 925$		
$573 + 6 = 579$	$3 + 6 = 9$			

Table 1. Idealized informal computation strategies

Typically, in Germany the jump and the split strategy are used most frequently by 3<sup>rd</sup>-graders. As described in Selter (2001) the jump strategy is preferred for subtraction problems and the split strategy is the favourite strategy for addition problems. Besides the two main strategies that always lead to correct results in comparatively simple steps<sup>1</sup> the other three strategies are suitable only for some problems and cannot be applied efficiently in general.

### STRATEGIC COMPETENCE

The investigation of the individual competency to choose an efficient strategy for a given addition or subtraction task firstly needs a description what “efficient” in this context means. Frequently, in quantitative empirical studies it is defined normatively which strategies are considered as efficient for a given arithmetic problem. In such cases generally the criteria are restricted to properties of the given task (e.g., in the studies of Beishuizen, 1993; Blöte, Klein and Beishuizen, 2000). However, it must be taken into account that choosing a strategy is always influenced by other variables, which depend on the person that solves the problem, like individual accuracy and speed when applying a strategy or self efficacy (cf. Siegler, 1996; Torbeys, Verschaffel, & Ghesquière, 2006). A model with four dimensions of strategic competence is given by Siegler (1996); it encompasses the individual strategy repertoire, knowledge about the strategy distribution and strategy effectiveness and competence in adaptive strategy selection. In addition to these individual variables it can be assumed that also socio-mathematical norms taught implicitly in mathematics lessons play a role for the strategy choice.

Summarizing empirical findings of the last decade for individual competence on adaptive strategy use for two- or three digit addition and subtraction problems it seems that primary school students achieve unsatisfactory results. Students are able to learn and apply particularly the split and jump strategies (in addition to the written algorithms), but they often use one of these informal computation strategies as a standard procedure, i.e., they apply frequently the same strategy for all addition (or all subtraction) problems ignoring number characteristics of the given problems (e.g. Selter, 2001; Torbeys, Verschaffel, & Ghesquière, 2006).

<sup>1</sup> There is a discussion whether the split strategy is useful for subtraction problems with regrouping. Some of the German textbooks introduce this strategy but avoid the notation of intermediate (negative) results.

## INFLUENCE OF THE DIDACTICAL APPROACH

Approaching the topic of mental computations in grade 2 and in grade 3 it can be observed that children have already a lot of pre-knowledge. Their conceptual understanding of the decimal number system allows them to find solutions for two- or three-digit addition and subtraction problems without an explicit teaching. A question that is still not solved is how teaching and learning processes can be organized such that students will acquire an adequate competence for an adaptive use of computation strategies. This encompasses the open question, whether there exists an approach which is beneficial for all students or whether different teaching approaches should be implemented for high achieving and low achieving students.

In the last 15 years different empirical studies were conducted investigating different didactical approaches. For example, the group of Beishuizen and colleagues showed that the adaptivity in using computation strategies in grade 2 is better, if children are asked to create their own computation strategies in the mathematics lessons instead of following given strategies in an instructional design (e.g., Blöte, Klein, & Beishuizen, 2000). Though many mathematics educators are convinced that such a constructivist oriented approach is most beneficial for students (cf. Threlfall, 2002), empirical findings of Torbeyns, Verschaffel, & Ghesquière (2006) indicate that 2<sup>nd</sup> graders learning computation strategies in an instructional oriented environment can also achieve a high adaptivity when solving addition and subtraction problems.

In general, two different types of didactical approaches are of interest in this context. On the one hand an instructional based approach that encompasses the successive teaching (and learning) of selected strategies and their efficient application. The aim is that, finally, these strategies are available as procedural knowledge, such that students can use their cognitive resources for choosing strategies adaptively for given arithmetic problems. Baroody (2003) describes this approach as “conceptual approach“. On the other hand, there is the “investigative approach” (Baroody, 2003) which emphasize the individual creation of own computation strategies. The students do not learn strategies given by their teachers; instead they develop and discuss their own approaches by analyzing characteristics of the given problems and the respective numbers. Based on their experiences and their accumulated knowledge on numbers the children will optimize their computation strategies step by step and acquire the competency how to apply strategies adaptively.

## RESEARCH QUESTIONS

In line with the research described in the previous sections we started a research project on the teaching and learning of informal mental computations strategies for adding and subtracting three-digit numbers. The first study in this research project was guided by the following research questions:

1. *How successful are German 3<sup>rd</sup>-graders in solving three-digit addition and subtraction problems?* Here we are distinguishing between two aspects: the



accuracy, i.e., if the solution is correct or not, and the adaptivity of the strategy choice, i.e., if the students choose an efficient strategy or not.

2. *Is there a relation between the two dimensions of strategy competence (accuracy and adaptivity)?* Generally, it is assumed that low achieving students are worse in choosing advantageous strategies than high achieving students.
3. *Are there indicators that the didactical approach influences the children's strategic competence?* As mentioned in the previous section there is empirical evidence that didactical approaches similar to the investigative approach are beneficial to foster adaptive strategy use. However, also children taught by a conceptual approach can achieve a high adaptivity when solving arithmetic problems.

### **SAMPLE AND DESIGN OF THE STUDY**

The sample comprises 245 students from grade 3 (about 8/9 years old) from twelve different classrooms. In four classes the teacher used a textbook basically following the conceptual approach, in four other classes a textbook was introduced emphasizing the investigative approach. The corresponding eight teachers can be described as teachers who are convinced of their textbooks and the underlying didactical approach. The remaining four classes used different textbooks without a clear didactical approach for teaching mental computation strategies.

For our study we used one booklet with 18 test items. On the one hand, we developed eight test items with addition (3 items) and subtraction (5 items) problems. For seven items from a mathematical point of view the most efficient way was to use the compensation, simplifying or indirect addition strategy (item examples  $379 - 99 =$  ,  $462 + 258 =$  or  $901 - 884 =$  ). The item solutions were rated two times: firstly as correct or incorrect and secondly by the quality of the strategy (see below). On the other hand, we included items on knowledge on numbers (6 items) and problem characteristics (4 items). All items were checked by primary teachers and tested in a pilot study to ensure that the item presentation is understandable for 3<sup>rd</sup>-graders. The test was administered by university assistants in the second half of grade 3, one week before the mathematics teachers introduced the standard algorithm for addition. Former studies showed that the adaptivity will decrease enormously after the introduction of standard written algorithms (e.g. Selter, 2001). The test time took 40 minutes, however, many children needed less time.

The analysis of the adaptive strategy use based on a bottom-up procedure, starting by a fine grained categorization. For the statistical analysis presented in this paper small categories were merged with others based on theoretical assumptions. Finally, for each item we assigned 0, 1 or 2 points to each category depending on a normative rating whether the used strategy was not appropriate to get a correct result (0 points), appropriate but not efficient (1 point) or efficient (2 points). The accuracy of the strategy use and the items on knowledge on numbers and problem characteristics were coded dichotomously (0 = incorrect, 1 = correct).

## RESULTS

### Accuracy and adaptivity of strategy use

Because of weak reliability and low discriminative power one item (finding numbers on a number line) of the scale “knowledge on numbers and problem characteristics” was omitted. For the overall test score with 17 items and for the single scales “knowledge on numbers and problem characteristics”, the accuracy of strategy use and the adaptive strategy use we got reliability values of Cronbach’s  $\alpha$  from 0.69 to 0.83. All scales showed a satisfactory distribution without a floor or ceiling effect.

For the accuracy of the strategy use for the eight addition and subtraction items we obtain a standardized mean value of  $M = 0.49$  ( $SD = 0.30$ ), this means that half of the items are solved correctly. Regarding the adaptivity of the strategy use the standardized mean value is  $M = 0.53$  ( $SD = 0.19$ ). This means that the mean strategy quality for the addition and subtraction problems can be described as “appropriate but no efficient” (see above).

Taking a more differentiated view on the adaptivity of strategy use we restrict our investigation to students’ solutions which contain at least an appropriate strategy, i.e., a strategy that can lead to a correct result. The solutions with wrong strategies (i.e., changing a plus sign to a minus sign etc.) are ignored. For the statistical analysis for each student we omit the items with wrong strategies and compute a standardized mean value for the strategy quality of the remaining item solutions<sup>2</sup>. As a mean value for the whole sample we get  $M = 0.44$  ( $SD = 0.27$ ). Here 0 stands for an appropriate but inefficient strategy use and 1 for an efficient strategy use. Interpreting this result we can conclude that on average nearly half of the appropriate strategies chosen by the children are already efficient strategies.

### Relation between accuracy and adaptivity

To examine the relation between the accuracy and the adaptivity of students’ strategy application we consider the correlation (Pearson) of both scales. Taking the adaptivity including the solutions with wrong strategies, we obtain a high significant correlation  $r = 0.590$  ( $p < 0.001$ ). This means that there is a comparatively strong relation between both variables. The scatter plot (not presented here) shows the shape of a triangle, i.e., there are students showing a low accuracy but a high adaptivity but not vice versa.

If we restrict the adaptivity scale to the item solutions with appropriate strategy use (efficient and inefficient), then we get a completely different picture. Here we cannot observe a significant correlation ( $r = -0.054$ ,  $p = 0.400$ ). This fact is confirmed convincingly by the scatter plot (Figure 1).

Thus, the strong correlation in the first case can be explained by the fact that inappropriate strategies are simultaneously rated by 0 points for the adaptivity and the

---

<sup>2</sup> The students used appropriate strategies (efficient and inefficient) for six of the eight items on average, such that the computed standardized value is meaningful.

accuracy, because they yield incorrect results. We want to mention that also inappropriate strategies of children can base on an adaptive choice as qualitative research reveals. Here we used a coarse coding due to the statistical analysis.

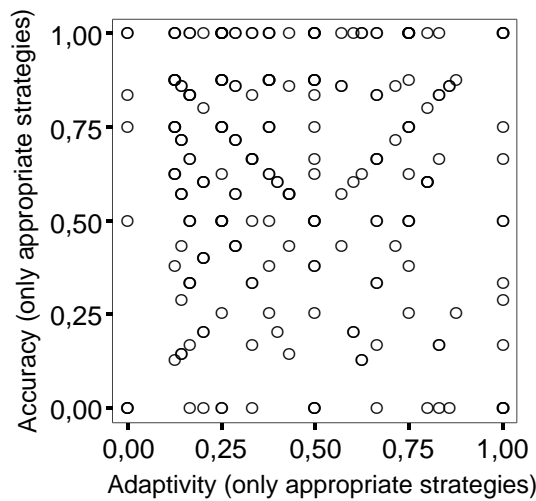

Figure 1. Scatter plot accuracy vs. adaptivity (appropriate strategies).

**Effects of the didactical approach**

Concerning this research question our data has to be interpreted carefully, because in this first study we did not observe the teaching activities. As described before our sample of 12 classrooms includes one group of four classrooms (N = 93) with teachers using textbooks based on the conceptual approach and one group of four classrooms (N = 72) with teachers using textbooks based on the investigative approach. All eight teachers appreciate the didactical approach of their textbooks. Based on these facts we assume that the teachers followed the approach of their textbooks. Nevertheless, we consider the following results only as a basis for further studies on this field.

The standardized mean values for the complete test with 17 items, for the scale “knowledge on numbers and problem characteristics” and for the accuracy of the strategy use are given in Table 2.

	Test score	Accuracy	Numbers and problem characteristics
Conceptual approach (N = 93)	0.57	0.57	0.61
Investigative approach (N = 72)	0.58	0.48	0.76

Table 2. Mean values for different didactical approaches

It turns out that there are no significant<sup>3</sup> differences between these two groups for the whole test and the accuracy. But students from the investigative approach group

<sup>3</sup> We used the Scheffé test, because altogether there are three different groups in the sample.

achieve better results for the items on number knowledge and problem characteristics ( $M = 0.76$  to  $M = 0.61$ ,  $p < 0.01$ ,  $d = 0.56$ ). This could be expected since this approach emphasizes this content as a basis for the individual creation of mental computation strategies.

Regarding the adaptivity of strategy use (including inappropriate strategies) we cannot observe significant differences between the groups with different didactical approaches (see Figure 2). However, for the strategy quality of appropriate strategies the investigative approach group achieve significant better results with a strong effect size ( $M = 0.56$  to  $M = 0.37$ ,  $p < 0.001$ ,  $d = 0.75$ ). This means that if students choose an appropriate strategy for a given item, then children taught by the investigative approach show a much better adaptivity than students from the conceptual group.

Taking into account the number of items which were solved with an appropriate strategy (efficient or inefficient) then the picture is contrary: the conceptual approach group shows significantly more solutions with appropriate strategies with a similar strong effect size ( $M = 0.85$  to  $M = 0.69$ ,  $p < 0.001$ ,  $d = 0.76$ ). It seems that the conceptual approach based on teaching selected strategies gives better opportunities to the children to learn at least one computation strategy which always could be applied. So, students of the conceptual approach group show a lower adaptivity when applying appropriate strategies but more of them are able to apply strategies which are at least appropriate.

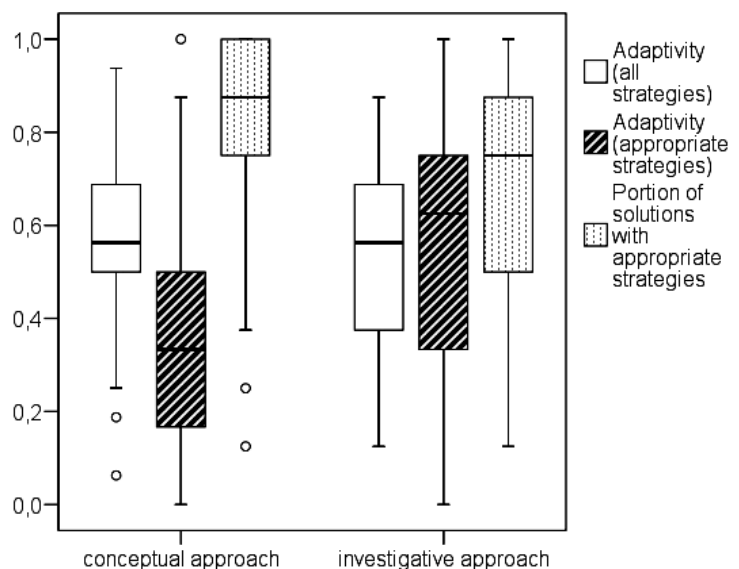

Figure 2. Adaptivity of strategy use and portion of solutions with appropriate strategies.

## DISCUSSION

Summarizing the results there are two interesting points. Firstly, our findings indicate that we should evaluate the adaptivity as a goal of mathematics classroom more detailed. Empirical studies revealed disappointing results for the adaptivity of strategy application for mental computations. However, we must differentiate between two aspects: (1) Are students able to find an appropriate strategy for a problem at all? (2) If yes, are they able to choose strategies adaptively? In our study on average a student was able to find an appropriate strategy for 74% of the items. Thus, for 26% of the items the quality of the strategies is automatically low (from the normative mathematical perspective we took here). Restricting our analysis to the solutions with appropriate strategies then we can observe that nearly half of the items were solved adaptively with efficient strategies. This can be considered as a nice

result and reminds of the fact that we have two goals for mental computations in mathematics classroom: to get a correct result and to get it efficiently.

Our findings concerning the didactical approach lead us to the question whether the investigative teaching approach to informal mental computation strategies is really the most appropriate for all children. In this first study we did not control what really happened in the mathematics lessons of our sample, such that we interpret the results in an explorative sense to generate hypotheses. It seems that both approaches have specific advantages, because the conceptual approach allows children in our sample to find appropriate strategies more frequently whereas the investigative approach yields a greater portion of efficient strategies in the test. Overall the students of both groups achieve the same mean values for accuracy and also for adaptivity when including the inappropriate strategies. In a next study in a controlled experimental or quasi- experimental design we will focus the question whether different student groups can benefit from these approaches in different ways.

### Endnote

This research was funded by the German Research Foundation (DFG), AZ HE 4561/3-1 and LI 1639/1-1. Moreover, we like to thank Franziska Marschick for her support during data collection and data analysis.

### References

- Baroody, A. J. (2003). The development of adaptive expertise and flexibility: The integration of conceptual and procedural knowledge. In A. J. Baroody & A. Dowker (Eds.), *The Development of Arithmetic Concepts and Skills: Constructing Adaptive Expertise* (pp. 1-34). Mahwah, N. J.: Lawrence Erlbaum Associates.
- Beishuizen, M. (1993). Mental strategies and materials or models for addition and subtraction up to 100 in Dutch second grades. *Journal for Research in Mathematics Education*, 24, 294-323.
- Blöte, A. W., Klein, A. S., & Beishuizen, M. (2000). Mental computation and conceptual understanding. *Learning and Instruction*, 10, 221-247
- Selter, C. (2001). Addition and Subtraction of Three-Digit Numbers: German Elementary Children's Success, Methods and Strategies. *Educational Studies in Mathematics*, 47, 145-173.
- Siegler, R. S. (1996). *Emerging Minds*. New York: Oxford University Press.
- Threlfall, J. (2002). Flexible mental calculation. *Educational Studies in Mathematics*, 50 (1), 29-47.
- Torbeyns, J., Verschaffel, L., & Ghesquière, P. (2006). The Development of Children's Adaptive Expertise in the Number Domain 20 to 100. *Cognition and Instruction*, 24, 439-465.
- Van den Heuvel-Panhuizen, M. (2001). Realistics mathematics education in the Netherlands. In J. Anghileri (Ed.), *Principles and Practices in Arithmetic Teaching* (49-64). Buckingham: Open University Press.

# ENCODING AUTHORITY: PERVASIVE LEXICAL BUNDLES IN MATHEMATICS CLASSROOMS

Beth Herbel-Eisenmann

David Wagner

Viviana Cortes

Michigan State University

University of New Brunswick

Iowa State University

*In this paper, we describe, interpret and critically examine characteristics of 148 secondary mathematics classroom transcripts to augment the mostly qualitative research on mathematics classroom discourse, which typically focuses on limited examples. Using corpus linguistics research methods, we examine pervasive “lexical bundles” (frequently occurring sets of words that are identified using a computer program) from eight secondary mathematics classrooms. We show that authority and positioning were pervasive in the classrooms.*

Mathematics education researchers have used many tools to examine discourse in various contexts. Almost all of this literature has drawn on qualitative research methods and has focused on a limited number of examples to describe, interpret, and sometimes critically examine phenomena related to teaching and learning in mathematics. We use a quantitative linguistic tool to examine 148 secondary classroom transcripts to illuminate authority structuring in mathematics classroom discourse. These structures have been partially addressed in qualitative scholarship, and we make suggestions for further qualitative work.

Following Pimm (1987) and others, we use the linguistic term *register* to refer to this discourse, defining register as a situationally defined variety of a language. Our analysis of the register draws upon a large database of transcripts of mathematics classroom conversations from a range of mathematics classroom contexts. Linguists use the word *corpus* for such a body of transcripts. Mathematics classroom research has not drawn on such corpora to identify pervasive features of this register. Except for Monaghan’s (1999) investigation of the ways the word *diagonal* was used in textbooks, and Wagner and Herbel-Eisenmann’s (2007) analysis of the word *just* in mathematics classrooms, corpus analysis has not appeared in mathematic education literature. Our approach differs from these two exceptions because it identifies pervasive patterns in the register instead of pre-selecting significant words for analysis, and differs from Monaghan’s because it analyses oral speech.

First we draw on the literature to describe some characteristics of the mathematics classroom register and other related registers, and connect these descriptions to literature on authority and positioning. Second, we describe our research methods. Finally, we share our findings from the analysis of the corpus, and raise issues associated with these findings. From this we will show that authority and positioning were pervasive in the register and we will argue that the ways in which these are encoded in language in mathematics classrooms needs further consideration by mathematics researchers, teacher educators, and classroom teachers.

## ACADEMIC DISCOURSE

Linguistic analysis has characterized academic discourse as decontextualised, explicit, and complex. Schleppegrell (2004) and others have argued for more nuanced analysis, noting the context of schooling, in which students are expected to “display knowledge authoritatively in highly structured texts” (p. 74). She and others have used Systemic Functional Linguistics and other tools to note the prevalence of abstract noun phrases, nominalization and high modality (Morgan, 1998), and the importance of metaphor for meaning-making (Pimm, 1987) in the mathematics register. Modality describes the authority or weight a speaker attaches to his or her utterances, and can be recognized in the use of modal auxiliary verbs, such as *must*, *will*, and *could*. Schleppegrell described the interpersonal function of language as being construed through the usually unconscious choice of the declarative mood, of modality and of attitudinal resources to convey stance. The declarative mood has a sense of authority because it positions the speaker as a giver of information and the listener as someone who receives information.

Biber, Conrad, and Cortes (2004) have shown that classroom teaching draws on both conversational and academic registers, and found that the classroom teaching register was even more structured by set-word combinations than either conversations or academic prose. These combinations, called “lexical bundles” are described as groups of three or more words that frequently recur in a particular register. Lexical bundle analysis considers larger chunks of a register than much discourse analysis, which looks at the word level but which helps us analyse lexical bundles. For example, pronouns indicate who is involved in processes, and imperatives indicate the nature of the processes. Analysis of such words helps us understand particular bundles.

Pimm (1987) described how mathematics teachers use the pronoun *we* when addressing students, without clarifying to whom *we* refers: the teacher with the mathematical community; the teacher with students; the teacher as an individual (the royal *we*); the students; or any combination of these. Regardless of who is included, the unconscious use of *we* points to issues of authority. Rowland (2000) showed how the pronoun *you* can be vague in a way similar to *we*. This sense of generality, which refers to no one in particular, suggests that anyone would or must do or understand the same thing. Though these pronouns recognize students’ mathematical action, they also take authority away from the students because it is implied that anyone would concede. There is no choice.

Rotman (1988) considered imperatives in mathematics communication. *Inclusive* imperatives (e.g., *consider*, *define*, *prove*) demand “that the speaker and hearer institute and inhabit a common world” (p. 9) and position the reader/hearer as a “thinker.” *Exclusive* imperatives position the reader/listener as a “scribbler” who performs actions relatively independent of interaction (e.g., *write*, *simplify*). Both scribbling and thinking are important in mathematics.

For analyzing lexical bundles, as for any form of discourse analysis, it is important to be clear about the register under consideration. We are focusing on the mathematics

classroom register, which we distinguish from the “mathematics register” (a term too often used for vastly different contexts). Furthermore, lexical bundles do not define a discourse. Rather, the pervasive lexical bundles allow us to focus on mundane combinations of words that often go unnoticed but that also have important structuring effects in the discourse (Biber et al, 2004). In particular, many of the bundles we examine here have been classified as “stance” bundles, identified by linguistic aspects including pronouns, modality and verb choice.

The ideas of authority and positioning are central to our interpretation of the lexical bundles because their forms are closely related to stance and interpersonal functions of language. Authority has been defined by Pace and Hemmings (2007) as “a social relationship in which some people are granted the legitimacy to lead and others agree to follow” (p. 6). This relationship is highly negotiable, as students rely on a web of authority relations with their friends and family members as well as the teacher (Amit and Fried, 2005). Following Harré and van Langenhove’s (1999) theorization of positioning, in which they show how any instance of language enacts known storylines and assigns positioning within the storylines, we claim that the recognition of the negotiable nature of storyline enactment has emancipatory power.

## RESEARCH METHODS

The Secondary Mathematics Classroom Corpus (SMC Corpus), which we analyse here, comprises 679,987 words. It represents 148 classroom transcripts from a 5 year NSF funded project<sup>1</sup> focusing on working with middle grades mathematics teachers to examine how doing action research on classroom discourse might impact teacher’s beliefs and practices over time. The SMC Corpus comprises mathematics classroom discourse from early in the project, before the teachers’ action research. The classrooms are varied in terms of levels of poverty, kinds of schools (e.g., gifted vs. low achieving), level (grades 6-12), kinds of curriculum materials used, and the gender, experience and education of teachers.

Classroom conversation were recorded and transcribed, then analysed using the Lexical Bundles program (designed by Cortes) to identify 4-word bundles that appeared at least 40 times and in at least 5 out of the 8 classrooms. This is relatively conservative for such analysis. We then used concordancing software to locate the bundles in their contexts (See Wagner and Herbel-Eisenmann, 2007, for elaboration on how such software is used).

Here we focus on the bundles we call “authority bundles” because they have implications for participant positioning and because they encompassed most of the bundle instances. They include those that had the pronouns *you*, *I*, or *we* because pronoun-use is an indicator of positioning. In the findings we refer to and interpret all of the authority bundles identified by the software (The bundles are underlined). In the presentation, we will list all of the pervasive bundles, not only the authority bundles, and we will give examples of the authority bundles in their contexts.



## FINDINGS AND DISCUSSION

One of the most important findings of this research is the quantitative evidence that interpersonal positioning is pervasive in mathematics classroom discourse. The authority bundles that we found in the corpus bundle analysis included 31 of 71 total bundles. This kind of bundle was also the most prevalent, representing 46.9% of all instances of the bundles. This is significant because lexical bundles are markers of what is important for people learning a register. The bundles represent ways of thinking and speaking within the register. Even if these authority bundles were common outside the mathematics classroom register, they would be significant to mathematics learning because of their prevalence. We found, however, that they were especially prevalent in the mathematics classroom. Comparing the authority bundles to findings from other corpus analyses, we found that 20 of the 31 bundles were unique to the SMC Corpus (The unique bundles will be identified in the presentation). Thus we asked in our analysis how the authority bundles connect to significant characteristics of mathematics learning. The most striking features of these authority bundles are: 1) the interpersonal relationships referenced by the bundles, and 2) the degree with which people are assumed to be complicit to a particular storyline. We organize our findings around these two features.

We first address more general findings about interpersonal relationships highlighted in the bundles and then address specificities of the register illuminated by these bundles that encode classroom participants' agency. As we use the lens of authority and positioning to describe the nature of the middle school mathematics classrooms in which these bundles appeared, we emphasize that these are pervasive practices. Authority and positioning are significant features of all mathematics teaching. Almost all of the instances of the bundles in this research were spoken by teachers.

### **Interpersonal relationships: *I, you, and me***

As noted by various linguists, personal pronouns are strong markers of personal positioning, so bundles with two personal pronouns are especially significant. These include I want you to, what I want you, I would like you, and you want me to. The pervasiveness of these bundles shows that there is an expectation in mathematics classrooms for people to comply with the desires of another - the teacher's role is to tell students what to do. Of these bundles, only you want me to included student utterances, always with the students asking what the teachers wanted them to do (e.g., "Do you want me to copy the steps?"). These interpersonal bundles also are not unique to mathematics classrooms. Nevertheless, as teachers use these bundles and similar phrases, they remind their students again and again of this particular storyline: students need to follow their teachers' wishes about both their mathematical processes and their social behaviour. When we tried to distinguish between mathematical and social expectations for each instance of the bundles, we found, as has Morgan (2006), that they overlap considerably. These interpersonal bundles directed us to ask of each instance of the authority bundles: 1) Why might the student do what the teacher wants? 2) How necessary is this complicity?

### **Shades of Complicity - Personal Authority**

The first shade of complicity we describe relates to the above set of bundles. When a teacher said “I want you to ...,” students were expected to follow the instructions though no reason was given. The teacher’s desire seemed to be sufficient reason. In the contexts, we found students following step-by-step instructions from the teacher, who did not give justification for processes. The storyline often evoked seemed to be an expert guide giving step-by-step instructions to inexperienced followers: “don’t think, just do what I say” - the kind of guidance we would look for when in imminent danger. Another storyline evoked with these bundles was a coach readying players for a game: “Visualize the situation, plan your action.”

In both cases, students were positioned as people who trusted their teacher to make good decisions about what should be done. Though this complicity did not allow for students to question their teacher’s guidance, the role of the student varied. In the first case, the verbs were scribbler verbs (using Rotman’s distinction for imperatives), structuring students working independently, exclusive from human interaction. The student “types,” “goes back,” and “takes.” In the second case, the verbs were thinker verbs, which positioned students to interact. The student “looks,” “thinks,” and “says.” We saw both kinds of positioning in all of the classrooms.

### **Shades of Complicity - Demands of the Discourse as Authority**

Other storylines were evoked in instances of the other bundles. With we have to do, we need to do, do we have to, you don’t have to, you have to do, you need to do, and do you have to there is still an authority external to the student, but this authority also demands complicity of the teacher. With these the personal pronouns *we* and *you* are prominent, drawing our attention to the generalizing sense of these pronouns, which assumes complicity. In any instance it is debatable to what extent these pronouns have a generalizing sense and to what extent they refer directly to the students. However, the reality for students is that the usage is ambiguous - the demand is directed at the individual and at the same time seems to be necessary for anyone in the same situation, and thus general. The auxiliary verbs that suggest complicity, namely *have to* and *need to*, in these bundles gives the sense of the generalizing *you*. This verb form also appeared in the bundle going to have to.

Generalization is characteristic of mathematical thinking, but also has implications for authority and positioning. The pervasive speech patterns contribute to the development of a sense of inevitability to mathematics. There is something, perhaps “out there,” that compels humans to act in certain ways. This gives students the sense that mathematics is a thing outside of human agency, and establishes or reinforces the idea that there is a mathematics discipline to which people need to be subject. We recognize that this storyline serves people and cultures well in various ways, but we reiterate that there are alternatives to this storyline. Nevertheless, the discourse (perhaps mediated through a teacher or a textbook) can prompt students to think deeply, even when the storyline is one of complicity.

### **Shades of Complicity - More Subtle Discursive Authority**

A more subtle sense of complicity appeared with the bundles you are going to, we're going to do, we are going to, so we're going to, so I'm going to, and and I'm going to. These did not feature auxiliary verbs that encoded complicity but there was still a sense of inevitability. One might say these bundles represented thinking ahead, but this was a special kind of forward thinking. It gave the sense that the speaker knows what will happen. The certainty of expression in these cases can be located in the auxiliary verbs *are* and *am*, which express higher certainty than, for example, if the teacher said “we might do” or “I think I’m going to...” Thus it is different from hypothetical thinking or thinking about various possibilities. The teacher, when using these bundles, invoked a storyline in which s/he was in control, and thus knew what would happen. With the instances of these bundles, it was easier to distinguish social from mathematical expectations. When the storyline indicated mathematical control, the teacher and students appeared subject to an established, inevitable mathematical procedure external from the particular humans in the classroom.

### **Shades of Complicity - Personal Latitude**

Positioning theory reminds us that there are other storylines possible in mathematics classrooms, with other kinds of positioning for students. Students do not have to be followers. While some of the bundles considered so far give glimpses of such possible storylines that position students with some authority, other bundles and their contexts much more explicitly recognized that humans make choices in mathematics.

Teachers' choices were often recognized with am I going to, do I need to, I'm not going to, and I was going to. Some of these accompany interrogative moods: when there is a question about what to do, choice is necessary. The others (I am going to and I was going to) suggest that there is no obvious procedure in the given situation. Other bundles showed that even novices in the discourse could make choices when doing mathematics. Students' decisions were recognized with if you want to, do you want to, you want to do, are you going to and are we going to. The first three in this set explicitly referred to students' desires (to what they “want”). Such recognition that human desire has a role in mathematics draws attention to the students' potential to exercise agency. Though these phrases could be taken as being used rhetorically, and thus not promoting authority, it is important to recognize that students can take them either way—as invitations to agency or as rhetorical suppression of agency.

The possibility for multiple interpretations was most evident in the last two bundles in the list. We noted earlier that *you* and *we*, when taken in a generalizing sense, encoded discursive authority. However, in the instances in which *you* and *we* seemed to refer directly to the participants in the classroom, as in many of the instances of the bundles listed in this section, the effect could be significantly different; these instances asked participants to articulate their choices. This kind of decision making was also clear in the bundles do we need to, do we have to, do you have to, and what do we do. In the instances of these bundles, even when *we* and *you* were used in the

generalizing sense, there was recognition that the classroom participants answered questions and made choices about apparent mathematical necessities.

Because students were positioned with some authority in these bundles, it is important to consider in which areas they were permitted personal latitude. We found differences between particular teachers. It is not clear to us what this idiosyncratic character of the bundles represents. Just as any conversation presents multiple possibilities for storylines, this idiosyncratic data allows various interpretations. One available interpretation is that the idiosyncratic use of the bundles represented the reality that experts in the mathematics classroom register (teachers, and proficient students) learn to use a common phraseology (learning the lexical bundles) and that they could use it for their own various purposes. This phenomenon exemplifies positioning theory's assertion that participants in a discourse use the discursive resources available to them to serve their purposes in terms of positioning. It also highlights the fact that teachers and students are participants in other discourses (e.g., home, community), which also shape their language practice in the classroom.

## CONCLUSION

The most important conclusion we draw is that the pervasiveness of authority bundles in the mathematics classroom register substantiates the claims in qualitative research that social positioning is very significant to teachers' and children's experience in mathematics classrooms. This supports the value of completed and upcoming research that investigates socio-cultural and linguistic phenomena that are associated with authority and related issues, such as positioning. Our study, with its large data set, needs to be complemented with more in-depth investigations of authority structuring in particular classroom situations.

Our intention with this report is to raise awareness about authority structures in mathematics classrooms and to promote reflection about alternative structures of authority and possible ways of establishing them. We are not saying that teachers should release their authority in their classrooms. Teachers need to use their authority to exercise their responsibilities for both social and mathematical outcomes (e.g., Chazan & Ball, 1999). Yet, there is a paucity of research related to productive ways to work with authority in mathematics classrooms. We suggest that the kind of in-depth studies of particular classroom episodes that our research compels should be done *with* teachers and not *on* them because teachers can offer interpretations and identify complexities that we, as researchers and teacher educators (who no longer teach in public schools), may not see. We note that the most powerful examples of changing classroom discourse to better empower students can be found in literature on teachers' action research.

As mathematics educators recognize how they encode the authority structures that are implicit in their classroom practice, it becomes possible to envision alternative authority structures. How are truth and value established in mathematics? Who should decide what mathematical questions are worth pursuing, and on what basis?

Participants in the development of mathematical understanding, namely students and teachers, are well-positioned to address these questions, and they alone have the authority to apply the answers to these questions in their mathematics classrooms.

### Endnote

This research was supported by the National Science Foundation (Grant No. 0347906). Opinions, findings, and conclusions or recommendations expressed here are the authors' and do not necessarily reflect the views of the foundation.

### References

- Amit, M. & Fried, M. N. (2005). Authority and authority relations in mathematics education: A view from an 8th grade classroom. *Educational Studies in Mathematics*, 58, 145-168.
- Biber, D., Conrad, S., & Cortes, V. (2004). If you look at...: Lexical bundles in university teaching and textbooks. *Applied Linguistics*, 25(3), 371-405.
- Chazan D. & Ball, D. (1999). Beyond being told not to tell. *For the Learning of Mathematics*, 19(2), 2-10.
- Harré, R. & van Lagenhove, L. (Eds.). (1999). *Positioning Theory: Moral Contexts of Intentional Action*. Blackwell: Oxford.
- Monaghan, F. (1999). Judging a word by the company it keeps: the use of concordancing software to explore aspects of the mathematical register. *Language and Education*, 13(1), 59-70.
- Morgan, C. (1998). *Writing Mathematically: The Discourse of Investigation*. Bristol, PA: Falmer Press.
- Morgan, C. (2006). What does social semiotics have to offer mathematics education research?. *Educational Studies in Mathematics*, 61, 219-245.
- Pace, J. L. & Hemmings, A. (2007). Understanding authority in classrooms: A review of theory, ideology, and research. *Review of Educational Research*, 77(1), 4-27.
- Pimm, D. (1987). *Speaking Mathematically*. London: Routledge and Kegan Paul.
- Rowland, T. (2000). *The Pragmatics of Mathematics Education: Vagueness in Mathematical Discourse*. Falmer Press: New York.
- Schleppegrell, M. J. (2004). *The Language of Schooling: A Functional Linguistics Perspective*. Mahwah, New Jersey: Laurence Earlbaum Associates.
- Wagner, D. & Herbel-Eisenmann, B. (2007). 'Just don't': The suppression and invitation of dialogue in the mathematics classroom. *Educational Studies in Mathematics*, online first.

# INSTITUTIONAL PRACTICES AND THE MATHEMATICAL IDENTITY OF UNDERGRADUATES

Paul Hernandez-Martinez

University of Manchester

*This paper reports on a study made at a Mexican university on the comparison between undergraduates from two different degrees, Applied Mathematics and Computer Science. The study focuses on the concept of (mathematical) identity, and seeks to investigate how this identity is mediated by the institutional cultures in which these students participate. The analysis of the data, obtained from questionnaires and interviews, shows that when students and lecturers engage in common practices within their institutions, they co-construct their identities and this in turn shapes the practices in which they participate.*

## INTRODUCTION

This paper is part of a study that aimed to explore how different undergraduate students build their mathematical identity and how this seems to be mediated by the institutional culture available to them. Here I report on the comparison of students undertaking undergraduate studies in Computer Sciences (CS) and Applied Mathematics (AM) at a Mexican university and how the academic activities in which these students participate seem to mediate their mathematical identities. The reason to choose these two groups of students for comparison obeys to the fact that both groups make substantial use of Mathematics during their undergraduate studies, but it was hypothesised that this subject takes different roles for each of them, and that this difference is influenced by the academic culture in which they develop as students.

## THEORETICAL FRAMEWORK

Recent studies point out the importance that the academic context has on the success or failure of undergraduates in mathematics (Solomon, 2007; Brown, & Rodd, 2004) and in particular, to the great influence that institutional practices have in the development of these students' understanding of specific mathematical concepts at university (Bingolbali & Monaghan, 2008). For example, in their study of Mathematicians and Mechanical Engineers, Bingolbali, & Monaghan (2004) use the concept of 'positional identity' (Holland *et al*, 1998) to explain how students *position* themselves differently as they participate in their respective departmental activities, and that this affiliation seems to influence their development of the concept of derivative. However, they acknowledge that their data is inconclusive about the dialectic nature of the relationship between identity and affiliation, and identity and knowledge development.

In this paper, I will try to add to the existent literature by further exploring the nature of the relationship between (mathematical) identity and institutional practices. The notion of identity that I used here is informed by Cultural-Historical Activity Theory (CHAT). Within this framework, identity is conceived not as an individual process but one

which is dialectically related to social practice. Hence, in the process of learning humans use (cultural) tools not merely to acquire knowledge but to become what they do, contributing to the communities with which they engage through activity. Moreover, because humans belong to a multitude of communities and engage in different activities throughout their lives, they are constantly building different aspects of their identity by which they function in different circumstances. For example, a person may enact certain parts of his/her identity to function as mathematics learners (which we call here mathematical identity) but also as teenagers, or future scientists. Certain elements of his/her identity might come into action, be left in the background, come into conflict or reconcile in different circumstances and times. Perspectives on CHAT also explain how different institutional and programme contexts can afford distinctive pedagogical systems (Daniels, 2001) and hence distinct cultures, i.e. pedagogic discourses and social norms (Gee, 2001; Yackel and Cobb, 1996). Therefore, these perspectives provide an appropriate framework to analyse and discuss the issues raised in this paper.

## **METHODS**

The study was conducted at a Mexican university, and the data was collected using the following methods:

- 1) An open ended questionnaire administered to 34 students (17 CS and 17 AM) about their views of mathematics, their experiences of Mathematics and Computer Science lectures, their use of mathematical knowledge in courses with mathematical content and their views on perceived influences on their development as university students.
- 2) Semi-structured interviews with authorities and lecturers from the Mathematics Department and the Computer Science Department about their views and practices in relation to mathematics within their academic departments. These interviewees were:
  - (a) The head of the Mathematics Department, (b) the head of the Computer Science Department, (c) the director of the degree in Computer Science, (d) a lecturer of the Mathematics Department who is a mathematician and lectures only to AM students, (e) a lecturer of the Mathematics Department who lectures to CS students, (f) a lecturer of the Computer Science Department whose background is in mathematics and lectures CS courses with mathematical content, (g) a lecturer of the Computer Science Department whose background is in CS and lectures CS courses with mathematical content.

The interviews and questionnaires were done in Spanish, as well as the analysis, and all quotations shown in this paper are my translation.

The answers to questionnaires were coded according to the four themes described above in 1). The interviews were transcribed and the relevant segments were coded according to the three themes described above in 2). I will now describe the results of the analysis.

## RESULTS

The analysis of the students' questionnaires showed that most of the CS students considered mathematics as a tool (although not the only or most important one) that could potentially be useful in their professional lives, while most of the AM students considered mathematics as a way to explain the world, a universal language, an enjoyable and logical discipline *as well as* a very useful corpus of knowledge.

About their mathematics courses, the majority of the students thought that these were in great part theoretical, although this was perceived as negative by the CS students who thought more examples would promote greater understanding while AM students saw this as positive because it encouraged deep understanding. A great part of the students thought that other courses with mathematical content were essentially practical which, contrary to their views on mathematics courses, was seen as positive by CS students who thought this provided opportunities for understanding while AM students tended to think that this type of courses promoted rote learning.

Regarding their actual use of mathematical knowledge in other subjects or academic work, most CS students said they used it only when requested by their teachers in particular exercises or coursework. The majority of them pointed to the fact that they were more likely to be motivated to use a mathematical concept in their CS studies when they had a good understanding of it, something that was very unlikely to happen in their mathematics lessons. Although they recognised mathematics as potentially a powerful tool, they seemed to suggest that they had very few opportunities to understand, link and hence make use of these concepts in their studies. For example, Amalia said:

It would have been very helpful if the teacher at high school had taught well the topics of integration, because I find them very difficult. This teacher didn't motivate or taught well, and I passed my examinations only because I studied from books by myself. Now I find them really complicated and I have to study by my own because the teacher here at university didn't teach them well neither.

And Francisco said:

I had the opportunity to use advanced topics of Mathematics I and II in different projects of robotics however, I haven't felt motivated to use them because I feel very insecure about them.

And, in spite of Mathematics being their main subject of study, some AM students face similar problems as CS students when applying (or trying to apply) it. Genaro said:

It is difficult to relate mathematics with practice.

Soraya suggested that there is a need to develop the skills that could enable them to make better use of their mathematical knowledge. She said:

I find it a bit hard (to apply Mathematics). The main reason is that we don't have workshops where we can develop this skill.



Despite agreeing that it is not always easy to apply Mathematics, Cesar thought to have an advantage as an AM students, as this could provide him with the necessary skills to solve problems. He wrote:

It is not always easy, but in general is easy, also because I haven't mastered all mathematics but definitely is easier. I think I have an advantage by studying mathematics, because it speeds up the mind and I know models that simplify things.

To the question of which were the factors that they considered most relevant to their development as an undergraduate student, the vast majority of the students mentioned their teachers (experience, motivation, clear explanations). Other few answers related to social factors (mates, parents, and personal problems) and factors related to their careers (interesting topics, enjoyment and integral education).

I am now going to describe the results of the interviews with the departmental authorities and lecturers. The analysis of these interviews suggested that in each academic department there is a different attitude towards how and why mathematics should be taught, mirroring the type of identities that students exhibited through the questionnaires.

The Mathematics Department is a well established department, having 24 full-time lecturers all with post-graduate degrees from prestigious national and international universities. In its webpage, they proudly proclaim to be one of the best Mathematics Departments in the country. The head of the department thinks that Mathematics should be taught in a formal and abstract way. "Calculus is Calculus, either you learn it or not", she said. And although she accepts the fact that applications can not be left apart, especially in the case of CS students, she feels that these should be taught at CS courses, leaving great part of the responsibility of applying Mathematics to the CS Department and its lecturers. She said:

It is expected that in the Computer Science courses students will take what they know of Mathematics and apply it there, and that lecturers will emphasise that they didn't learn it only to fill up their heads, but to become aware that it is useful to them.

During the time of the interview, she had plans to open the Mathematics courses for AM students to the CS students who wished to have a more "solid" knowledge of Mathematics, in the hope that these students would then be able to use this knowledge more efficiently. The division between theory and applications and who is responsible of teaching them has been increased by a lack of communication between the two departments. In her point of view, she has invited several times the authorities of the CS Department to have a greater participation in the design of the curricula of Mathematics courses for CS students, but they do not seem to be very interested.

This "formalistic" view of mathematics and its teaching is shared by the lecturer of the Mathematics Department who lectures to AM students. His point of view about Mathematics resonated with that one of the AM students. He said:

Mathematics is an abstract science, in which you construct a logical theory out of basic principles, the axioms, and you construct new theorems which you prove their validity following the rules of logic.

(...) The purpose of my lectures is that students understand that mathematics is that, not too much their applications or how are they going to use it, but what does that particular mathematical object is, the same vision that I have.

(...) A Mathematics course for economists is, at the end, a course of Calculus. If they want practical things, they should hire an economist.

The Mathematics lecturer that teaches to CS students recognises that most of her colleagues, including sometimes herself, teach at a level where understanding of the mathematical concepts does not take place. She said:

I suspect that in many courses teachers teach at a very low level, in which they ask students to repeat what they write on the blackboard, to do homework, to memorise a procedure, and that can last 6, 7 weeks and that's all.

(...) I am one of the few that makes an effort, and maybe it's because I am interested in these matters, but I am aware of my own limitations.

(...) People do not want to make the effort. And there is the belief that if they learned like that, others have to be able to learn it in that way also.

The Computer Science Department is a relatively new department, having 14 full-time lecturers, most of them with post-graduate degrees. The curricula of the degree in CS contain 10 Mathematics and Statistics courses (out of 40 in the whole degree) lectured by the Mathematics Department, and several compulsory and optional CS courses with highly mathematical content, at least in paper. In an interview to the director of the degree of CS which was published in the newspaper of the university, she expressed that the degree seeks to shape its students towards the design of solutions to practical problems using existent bodies of knowledge rather than to the creation of new theoretical knowledge. When I interviewed her, she expressed her opinion about the role of Mathematics in CS subjects:

Most of our students will never again see anything related to mathematics when they go out of university. However, I realise that although many things will never be used again, the sum of everything that you study at university will make you a better or worse professional.

The head of the CS Department talked about the use of mathematical knowledge in the CS courses. He said:

We present the Fibonacci problem as a classic example of a series of numbers in which the student only has to store two of them and the others are calculated by using the first two. Therefore, we do not stress the mathematical part of the problem but the algorithmic part or the computational technique required to solve the problem, and we exemplify it with some mathematical problems... how do we stop the sine series, for example, if we want to calculate only five of its terms, if we have to use a "for", or we could ask for the difference between two numbers and determine which of them is greater, and if we can use a "while" structure to stop the calculation.

The CS lecturer with a mathematical background thinks that there is no point in asking students to make a proof or delve into the mathematical side of the problem. He said:

In general there is a lack of mathematical ability in these students, I have found that they are very mechanical, therefore in my lectures in which there are mathematical topics I practically do not prove anything, but even without proving students find really hard to reason, that is the main problem. It's like they are lazy to think.

And the CS lecturer with a computational background has a point of view that the Mathematics that is taught in Mathematics courses has a very restricted applicability to real problems. Therefore, in his lectures he prefers to stress the computational side of problems rather than the mathematical one. He said:

Great part of pure Mathematics has the limitation that when you want to apply it to real problems you have to suppose a series of things about the mathematical problem that you want to solve. These things hardly happen in practice, and the problems end up becoming what it is known as “toy problems”, in which you get a solution to a problem that is so simple that it illustrates what you are teaching but in real life it has no importance at all. Therefore, students forget this knowledge because here they are taught to solve linear equations of 2 or 3 variables, but in the real world equations are not linear or have only 3 variables. That is the problem.

(...) In my lectures I say to them: “I am not going to teach you everything, I will teach you three or four things and you have to learn how to solve them”. In the lecture where you sat, Applications to Artificial Intelligence, I avoid all the mathematical foundations, I teach them how to solve problems and if they are interested in why they work like that, I will put references, but I am mainly interested that they know how to use it.

## DISCUSSION

The analysis of the students' answers to the questionnaire showed that there are important differences in the mathematical identity of each group of students considered in this research. On the one hand, a great majority of the AM students identify themselves with a subject through which they can explain the world, a logical and enjoyable field of study which can *also* be quite useful. On the other hand, CS students' mathematical identity can be described as more utilitarian: Mathematics is a tool, out of many, that can be used to solve problems within their professional area. The fact that most of the CS students' views about their Mathematics courses were negative in the sense that they believed that deep understanding was unlikely to be achieved in these courses, while AM students considered that theoretical courses encouraged deep understanding, shows how these groups of students construct different mathematical identities which are mediated by the practices in which they engage. These identities are enacted when these students make use (or not) of mathematical concepts in their studies. CS students feel “insecure” in using mathematical concepts in practical tasks, and although this might not be very different for AM students, some of them achieve to construct an identity in which motivation is high and this in turn can make the relation between theory and practice look “easier”.

Almost all the students in the sample considered that their teachers were the greatest influence in their development as undergraduates. This gives evidence to the fact that

the construction of students' mathematical identity is mediated by their lecturers' experience, beliefs, motivation and knowledge, in few words, by their lecturers' identity. This identity is in turn mediated by the rules of the institution to which they belong and in which they, like the students, participate.

This can be clearly seen in the analysis of the interviews with departmental authorities and lecturers. The authorities and lecturers interviewed in both departments have different viewpoints about Mathematics and why and how it should be taught.

The head of the Mathematics department and the lecturer who lectures to AM students agree that mathematics should be formal, abstract, and the relation of it to its possible applications should be left for the CS courses. They think that AM students should be taught to appreciate the beauty inherent in the mathematical theories and that understanding comes from logic. And although the Mathematics lecturer that lectures to CS students seems to make an effort to significantly impact on her students, she realises that most of her colleagues only teach in a "low level", where procedures and memorisation are the rule. This way of seeing mathematics and its teaching resonates with the AM students' identity that sees mathematics as a way to understand and explain the world, and where abstract lessons encourage understanding; motivation to its study seems to come from this point of view.

The two authorities of the CS Department agree that Mathematics is not an essential part of the CS degree, mathematical concepts are only to be used as examples of how computational techniques can be used, and it is very likely that most students will never again use mathematical concepts when they graduate. The lecturers in this department teach courses in which Mathematics plays a minimal role, and although they have different reasons for this, their practices are similar. This point of view about Mathematics is reflected in the CS students' identity in which Mathematics is a tool, just another way to solve problems, and in real life it has little to none weight.

It can be seen, therefore, that the mathematical identities of these authorities and lecturers mediate the students' identities described above. But not only that, students and lecturers co-construct their identities when they engage in the common practices. Williams (2007) says that classroom practices are a source and resource for the identity work of learners and teachers both, and

What goes on there is mediated by outside communities, via the cultural resources that teachers and learners bring to the activity therein. And in their turn, these cultures provide resources for learners and teachers narrations of identity (p. 9)

Lecturers in both departments adjust their practices according to their mathematical identity, which in turn is mediated by the rules of the institution to which they belong, and adjust these practices to what they believe their students can or should achieve, or would be useful to them. In this sense, 'students and their communities exert pressures on teachers' room for manoeuvre in their turn' (*ibid*: 9).

In conclusion, we have seen how students' and lecturers' mathematical identities are shaped by the practices in which they engage, but at the same time, these practices

are also produced according to the identities of the participants: identity and practice co-evolve in a dialectic process.

## References

- Bingolbali, E. & Monaghan, J. (2008). Undergraduates' understanding of the derivate. In Watson, A. & Winbourne, P. (Eds.). *New Directions for Situated Cognition in Mathematics Education*, pp. 233-260, New York: Springer.
- Bingolbali, E. & Monaghan, J. (2004). Identity, knowledge and departmental practices: Mathematics of Engineers and Mathematicians. In M. J. Høines & A. B. Fuglestad (Eds.), *Proceedings 28th Conference of the International Group for the Psychology of Mathematics Education*, (Vol. 2, pp. 127-134). Bergen, Norway: PME.
- Brown, M. & Rodd, M. (2004). Successful undergraduate mathematicians: a study of students in two universities. In M. J. Høines & A. B. Fuglestad (Eds.), *Proceedings 28th Conference of the International Group for the Psychology of Mathematics Education*, (Vol. 4, pp. 97-104). Bergen, Norway: PME.
- Daniels, H. (2001). *Vygotsky and Pedagogy*. London: Routledge.
- Gee, J.P. (2001). Identity as an analytic lens for research in education, *Review of Research in Education*, 25, 99-126.
- Holland, D., Lachicotte, W., Skinner, D., & Cain, C. (1998). *Identity and Agency in Cultural Worlds*. Cambridge, Mass: Harvard University Press.
- Solomon, Y. (2007). Not belonging? What makes a functional learner identity in the undergraduate mathematics community of practice? *Studies in Higher Education*, 32(1), 79-96.
- Williams, J. (2007). Community, culture, and identity: pedagogy as mediation between teacher's and learner's identity? Paper presented at the *2nd ScTIG Conference*, Manchester, UK.
- Yackel, E. & Cobb, P. (1996). Sociomathematical norms, argumentation, and autonomy in mathematics. *Journal for Research in Mathematics Education*, 27, 458-477.

# EARLY MATHEMATICS LEARNING THROUGH EXPLORATION WITH PROGRAMMABLE TOYS

Kate Highfield, Joanne Mulligan, and John Hedberg  
Macquarie University

*New technological toys, such as simple robotics, allow young children to engage with complex mathematical processes from an early age. This paper describes pilot data of two case study children, aged five and eight years, exploring a Bee-bot programmable toy. The dynamic capabilities of this tool enabled the children to engage in transformational geometry, iteration of the toy as a unit measure and semiotic processing. The children demonstrated development of problem-solving strategies and relational thinking to plan, program and manipulate the toy through a complex pathway. Their use of kinaesthetic motion mimicked their mathematical thinking and the process of programming the toy provided unique opportunities for action and reflection.*

## INTRODUCTION

There is a significant increase in the availability and presence of technological toys in children's play. Young Australian children are frequently immersed in technological media; including digital toys and or those linked to electronic media. Programmable toys, such as simple robots, provide one example that allows children to plan and program the actions of a 3-dimensional object. In programming these toys and then in observing the execution of a sequence of stored instructions, young children can develop mathematical concepts and cognitive processes. The dynamic nature of these toys leads to exploration of spatial concepts and dimensionality, transformational geometry and directionality, measurement and fraction concepts, proportional reasoning and problem-solving strategies. These toys also show potential for the development of cognitive infrastructure (Hoyles and Noss, 2003) where prediction and reflection are interwoven into the process of programming an action and then observing the toy execute the action. Battista (1999) describes the power of prediction and suggests that opportunities for cognitive perturbations can be powerful, with discrepancies between the child's predicted outcome and the actual outcome creating cause for reflection.

## BACKGROUND

### **The role of technology in early mathematical development**

There is limited research investigating young children's use of technology in early mathematical development (Yelland, 2005). Much of this research has focussed on screen-based tools and the use of technology as a representational tool with several projects indicating that computer-based technology has potential to enhance development of children's representations of mathematical thinking (Clements, 1999; Highfield, & Mulligan, 2007; Moyer, Niezgod, & Stanley, 2005).

Earlier research investigating Logo ('turtle' geometry) to develop mathematical understandings has some parallels to that of modern programmable toys. Advocates of Logo assert that the child's ability to program and the subsequent representations allow children to "externalise intuitive expectations" and so make concepts "more accessible to reflection" (Papert, 1980, p. 145). In using the computer-based Logo tool children program a 'turtle' icon to move around the screen using alpha-numeric symbols to input directions. Programmable toys can be considered a concrete embodiment of the 'turtle' that acts as a representational tool in a 3-dimensional plane. These toys also offer a more tangible, user friendly and less abstract introduction to programming. While studies on the use of Logo are inconclusive there appears general support for the use of Logo in teaching and learning mathematics (Clements & Sarama, 1997; Hoyles, 1987; Yelland, 1995) particularly in the field of geometry and spatial concepts (Clements & Battista, 1992).

### **Robotics and Programmable Toys**

There is a significant body of research on the use of robotics in workplace contexts and an increasing amount of research investigating these tools for educational purposes. Much of this work has focussed on the use robotic tools, such as Lego NXT and Lego RCX with older children (Lund & Pagliarini, 2001). Sklar, Eguchi, & Johnson (2003) indicate that 80% of teacher/mentors working with children on robotics projects felt that students' mathematics skills were helped through their involvement in a robotics challenge. However, these reports relate to teacher perceptions, rather than data identifying the development in mathematical skills. Petre and Price's work (2004) with primary and high-school aged children suggest that the appeal of robotics may mean that these technologies serve as a vehicle to facilitate learning generally.

The research on young children's use of robotics and programmable toys is limited and is frequently observational or describes broad skills. The limited research does however suggest that these tools have potential for teaching and learning. Macchiusi (1997) and Piper (2001) both investigated young children's use of a Valient Roamer robot. Macchiusi investigated problem-solving and Piper described some mathematics skills, including measurement of distance, identification of units of measure, estimation and early geometry. The work of Bers, Ponte, Juelich, Viera and Schenker (2002) suggests that robotic construction kits, a type of a programmable toy, such as Lego NXT "offer a new kind of manipulative for young children to explore and play with new concepts and ways of thinking" (p. 124). Beal and Bers (2006) also demonstrate young children as having the potential, with appropriate assistance to develop complex robotic projects. The introduction of cost effective programmable toys (such as the Bee-bot) in Australian classrooms is increasing and there is action research occurring that indicates that these toys have a potential role to play in the development of mathematical concepts. However, there is not yet a coherent body of empirical research to support pedagogy or practice. The role of programmable toys in the development of mathematical concepts and representations has not yet been adequately articulated.

## AIMS AND RESEARCH QUESTIONS

This paper describes pilot data of two case studies from a larger project investigating the mathematical and meta-cognitive processes that young children develop as they experiment with programmable toys (Bee-bot, Probot and Lego NXT). This current work begins to address the following research questions.

1. How can young children’s use of programmable robotic toys promote the development of mathematical problem-solving, and meta-cognitive processes?
2. What forms of mathematical reasoning and strategic thinking are observed while children plan and program a Bee-bot to solve problems?

## METHOD

Ten children aged between three and eight years participated in a pilot study designed to evaluate an assessment interview and describe the mathematical processes elicited when exploring a Bee-bot toy. Case study methodology allowed for micro-analysis of gestures, actions and dialogue, mathematical and cognitive processes (Edwards, 2003). This paper reports an analysis of two cases, “Michael” and “Lachlan”, aged eight and five years respectively. Each child completed a semi-structured interview and then explored one programmable toy with the assistance of the researcher, as co-learner. In the case of Lachlan, his mother and younger sibling also engaged in the exploration. Digital recording of interviews and the children’s exploration enabled close analysis and coding of mathematical and cognitive processes.

The assessment instrument comprised a semi-structured interview designed to ascertain the children’s prior experience with robotic toys. The researcher also showed the children how to input a program to make the Bee-bot move in a square. This was followed by a discussion of this process.

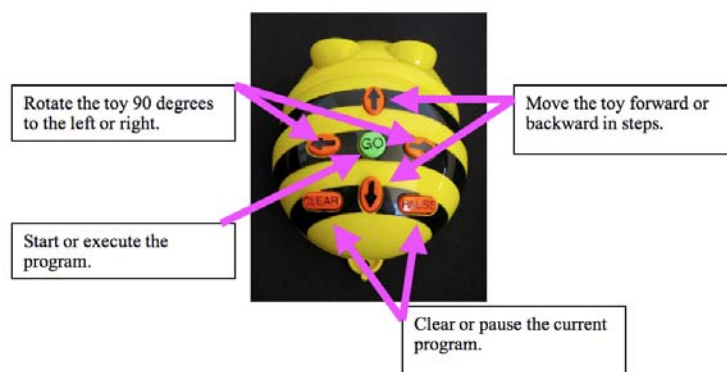

Figure 1. Features of the Bee-bot programmable toy.

The robotic tool (a Bee-bot) was selected due to ease of operation and its general appeal to young children. This simple robotic toy is produced by the TTS group LTD and has seven buttons. Four of these program directions, one clears the current program, one pauses the program and one executes the inputted program. The toy can store up to 40 steps in its’ program (see Figure 1).



## DISCUSSION OF FINDINGS

Both cases described here had no prior experience with programmable toys and at initial interview neither could demonstrate or explain the toy's functioning. After brief exploration, scaffolded by the researcher, both children were readily able to plan, input and execute simple programs.

During the exploratory session described here Michael experimented with the Bee-bot for 28 minutes and Lachlan for 23 minutes. Their engagement with the toy was considerably more sustained than several other children who formed part of the larger pilot group (who sustained interest from 6 to 18 minutes duration).

Michael initially explored the use of the arrow symbols to move the Bee-bot. He then attempted a series of tasks evoked by the researcher: using the Bee-bot to make a square; measuring the length of a large floor tile (see Figure 2 and accompanying transcript); and making a path (track) and moving the Bee-bot through the path (see Figure 3 and accompanying transcript).



Figure 2. Using the Bee-bot's unit of length to measure the floor tile.

Michael: That could be one, moving up one, moving up once, twice, maybe three time  
*(partitioning the floor tile)*

Interviewer: OK, so you're trying to measure how long the tile is in bees?

Michael: *(runs program measuring the tile)*.

Interviewer: OK, so how many bees was it?

Michael: About two and a quarter I think.



Figure 3. Walking through the maze, acting out and planning the robot's actions.

Michael: I meant it to go up twice, 1, 2.

Interviewer: and turn?

Michael: Then I want it to go left. Then go up twice, one, two.

Interviewer: yes

Michael: Then turn right and go up twice.

Lachlan also explored the Bee-bot's arrows and movements and initiated a task to make it rotate through 360°. He then made a path with marker pens placed edge to edge (on either side of the path) and programmed the Bee-bot to move along this path (see Figure 4 and accompanying transcript). The path was then altered to make the task more challenging, so Lachlan re-programmed the Bee-bot to successfully navigate it.



Figure 4. Lachlan calculates Bee-bot steps to complete track<sup>1</sup>.

Interviewer: How many times forward do you think that will have to be?

Lachlan: One, two (*lifting and moving the Bee-bot forward in two jumps*).

Interviewer: How many forward buttons do you think you'll have to press?

Lachlan: Four.

*(Using trial and error Lachlan completed the task, it took eleven steps for the Bee-bot to finish the track).*

While Michael and Lachlan engaged in the problem-solving task of making a track for the Bee-bot, no other children in the pilot group (in their individual settings) experimented with the toy in this way. Both boys were determined to complete the goal of successfully navigating the track, and this appears to have increased their motivation and sustained their attention.

### **Mathematical processes observed**

Both children engaged in actions showing transformational (geometric) properties, particularly rotations and linear motion. They were observed visualising, acting out and using gestures to symbolise the rotation, direction and movement of the Bee-bot. They also demonstrated understanding of directionality through articulating their planned execution of the program. Michael's discussion was more advanced than Lachlan's; Michael using positional language such as "left" and "right".

The children also used the Bee-bot's pre-programmed "step" as a unit of measure, by comparing the length of the "step" to the length of the Bee-bot itself (as distinguished

---

<sup>1</sup> Video footage of these three figures will be shown at PME presentation.

from the width). They visualised and estimated the number of iterations and counted aloud, using perceptual and then abstract unitary counting, to find the number of units required. Michael also used early fraction concepts, partitioning and describing distance as part of a whole tile.

### **Programming the robot: semiotic processing**

Both children were initially confused when using the arrows to input programs. They anticipated correctly that the forward and back arrow moved the Bee-bot in a forward and backward motion. However, in generalising the use of the symbols both children assumed that the left and right arrows would move the Bee-bot sideways. After experimentation the children appeared to re-assign the left and right arrows new meaning; a 90° left or right rotation. This was different to the semiotic interpretation frequently ascribed to a left and right arrow. Thus, the children initially persisted in ascribing incorrect meaning to the arrow, resulting in repeated attempts to move the Bee-bot through turns in the path. This semiotic complexity added a level of abstraction to this otherwise intuitive interface. Both children found the Bee-bot's pre-programmed rotational movement of 90° limiting. Neither child could articulate this frustration; however both attempted to make the Bee-bot move either more or less than the pre-set 90° rotation.

### **Problem-solving Processes**

The successful programming of the Bee-bot through the path required simultaneous and successive problem-solving strategies. Both children 'acted out' through gesturing the robot's movement through the desired actions before programming it. Lachlan consistently held the toy and moved it along the track. Michael used his body to demonstrate the action of the Bee-bot's intended path, approximating his step length to demonstrate the iteration of 'Bee-bot units' of length. The kinaesthetic motion clearly mimicked the children's mathematical thinking.

Both children used hand gestures in their planning and verbalised their planned actions, using semiotic language ("step forward", "turn that way" etc) as they progressed through gesticulation and action. Similar processes are described by Nunez highlighting the "intimate link" between the children's gestures and language (2007, p. 148). As the directions needed to be selected and inputted from the robot's perspective rather than the child's point of view the strategy of "acting out" and verbalising appeared integral to successful problem-solving. The insights gained as the children manipulated and moved the Bee-bot in this way advances earlier studies of Logo, where children could direct the object on screen but could not physically interact and manipulate the "turtle". This 3-dimensional interaction may mean that complex programming of this kind can be successfully introduced to younger children, and a larger variety of embodiment strategies utilised.

At a general level the children's problem-solving strategies relied on experimentation and many examples of trial and error, reflection, and action on reflection were observed. The children's reflective process is somewhat inherent in the use of

programmable toys and their learning appeared to advance rapidly as a consequence of cognitive dissonance (when the Bee-bot performed in an unexpected manner).

## CONCLUSIONS AND FURTHER RESEARCH

From these data it was observed that the Bee-bot has the potential to enhance children's development of mathematical concepts, particularly transformation and measurement processes much earlier than traditionally expected. There were unique opportunities arising from the use of the programmable toy because it could be physically manipulated. This potential and the non screen-based programming enabled a variety of alternate problem-solving strategies. The children each engaged in a unique process of action and reflection which led to abstract thinking. These cognitive processes can be described as integral to the development of cognitive infrastructure in mathematics learning (Hoyles & Noss, 2003).

In both cases the combined power of the Bee-bot and the desire to complete the track task motivated the children. These children's sustained attention may be attributed to the motivating nature of the task, the use of the toy and scaffolded interaction with the researcher. This differed from cases in the larger pilot group, who were less engaged and did not complete structured tasks such as making a track.

These findings directly impact on the next phase of this research, where project-based tasks will be utilised with a range of programmable toys with 35 children aged four and eight years. Microgenetic analysis of eight embedded longitudinal case studies will employ video stimulated recall interviews to more closely investigate meta-cognitive processes and mathematics learning.

## References

- Battista, M. (1999). Fifth graders' enumeration of cubes in 3D arrays: Conceptual progress in an inquiry-based classroom. *Journal for Research in Mathematics Education*, 30, 417-448.
- Beal, L. & Bers, M., (2006). Robotic technologies: when parents put their learning ahead of their child's. *Journal of Interactive Learning Research*, 17(4), 341-358.
- Bers, M., Ponte, I., Juelich, C., Viera, A., & Schenker, J. (2002). Teachers as designers: Integrating robotics in early childhood education. *Information Technology in Childhood Education Annual*, 1, 123-145.
- Clements, D. (1999). 'Concrete' manipulatives, concrete ideas. *Contemporary Issues in Early Childhood*, 1(1), 45-60.
- Clements, D. & Battista, M. (1992) Geometry and spatial reasoning. In D. A. Grouws (Ed.), *Handbook of Research on Mathematics Teaching and Learning* (p. 420-464). New York: Macmillan.
- Clements, D. & Sarama, J. (1997). Research on Logo: a decade of progress. *Computers in the Schools*, 14 (1), 9-46.
- Edwards L. (2003). A natural history of mathematical gesture, *Proceedings of the American Educational Research Association Annual Conference*, Chicago, April 2003.

- Highfield, K. & Mulligan, J.T. (2007). The role of dynamic interactive technological tools in preschoolers' mathematical patterning. In J. Watson, J. & Beswick, K. (Eds.), *Proceedings of the 30th Annual Conference of the Mathematics Education Research Group of Australasia*, Vol 1, pp.372-381. Adelaide: MERGA Inc.
- Hoyles, C., (1987). Tools for learning- insights for the mathematics educator from a Logo programming environment. *For the Learning of Mathematics - An International Journal of Mathematics Education*, 7 (2), 32-37.
- Hoyles, C. & Noss, R. (2003). What can digital technologies take from and bring to research in mathematics education? In A. Bishop, M. Clements, C. Keitel, J. Kilpatrick, & F. Leung (Eds.), *Second International Handbook of Research in Mathematics Education*, pp.323- 349. Dordrecht: Kluwer.
- Lund, H. & Pagliarini, L. (2001). Edutainment robotics: applying modern AI techniques. In *Proceedings of 1st International Conference on Autonomous Minirobots for Research and Edutainment - AMiRE2001*, Paderborn, Germany, October 22-25, 2001.
- Macchiusi, L. (1997). Children, robotics and problem solving: Technology in the early childhood classroom. *Australian Educational Computing*, 12(2), 24-31.
- Moyer, P., Niezgoda, D., & Stanley, M. (2005). Young children's use of virtual manipulatives and other forms of mathematical representation. In W. Masalski & P. Elliott (Eds.), *Technology-Supported Mathematics Learning Environments* (pp. 17-34). Reston, VA: NCTM.
- Núñez R. (2007). The cognitive science of mathematics: Why is it relevant for mathematics education? In R. Lesh, E. Hamilton, & J. Kaput (Eds.), *Foundations for the Future in Mathematics Education* (pp. 127-154). Mahwah, NJ: Lawrence Erlbaum Associates.
- Papert, S. (1980). *Mindstorms: Children, Computers and Powerful Ideas*. Brighton: Harvester Press.
- Petre, M. & Price, B., (2004). Using robotics to motivate 'back door' learning. *Education and Information Technologies*, 9(2), 147-158.
- Piper, G. (2001). Early years roaming. *Micromath*, 17(2), 10-13.
- Sklar, E., Eguchi, A., & Johnson, J. (2003). RoboCup Junior: Learning with educational robotics, *AI Magazine*, Summer, 43-47.
- Yelland, N. (1995). Mindstorms or a storm in a teacup? A review of research with Logo. *International Journal of Mathematics Education, Science and Technology*, 26(6), 853-869.
- Yelland, N. (2005). The future is now: A review of the literature on the use of computers in early childhood education. *Association for the Advancement of Computing in Education*, 13(3), 201-232.

# DEVELOPING UNDERSTANDING OF TRIANGLE

Marj Horne and Kelly Watson

Australian Catholic University

*As children develop concepts of shape they move from a visual understanding to a property based approach to classification. In this study two cohorts, one a longitudinal study from grade 1 to 4 and the other a sample across a school from pre-school to grade 8, were asked to identify triangles. The resulting data shows errors of inclusion are greater than errors of exclusion and suggests an order in which particular properties are attended to as children learn.*

## INTRODUCTION

One aspect of the study of geometry is the study of spatial objects. Children begin at an early age to explore shape and by the early years of school many are identifying and using the names of simple two-dimensional shapes such as triangle, square, circle and rectangle. While many children in these early years use some of this language, their understanding of the concepts develop over time. In the Early Numeracy Research Project (Clarke et al, 2002) children in the first years of school were asked in an interview assessment to sort some simple shapes to provide an opportunity for them to use the language and talk about the shapes. The researchers were surprised while piloting the tasks when a few children, some as old as grade 3 and 4, sorted the triangles into two groups labelling one group triangles but not having a name for the other group. A few called them half triangles because they were ‘too long and pointy to be triangles’. This raises the question of children’s developing understanding of shape and, in particular, triangle.

A number of theories have been proposed to describe children’s conceptual development and understanding in this area. The best known of these is the van Hiele theory (Clements & Battista, 1992). At the first level children demonstrate a prototypical knowledge of the shapes recognising them holistically. At the next level, while still seeing the shapes children recognise the properties of the shapes and conversely recognise shapes by their properties. By level three they classify the shapes hierarchically and see the relationships between the properties and shapes being able to recognise aspects such as necessary and sufficient conditions. The original theory was that levels were discrete and students would move from one level to the next but the research evidence suggests that students may be at different levels for different concepts and oscillate between levels (Battista, 2007).

Further understanding of students’ developing understanding and the blurring of the boundaries between the originally proposed levels have led to different types of reasoning being associated with each level (Battista, 2007). At the first level visual reasoning dominates alongside the visual-holistic knowledge. At the same time the child begins to develop descriptive-analytic reasoning connecting to descriptive

verbal knowledge. The third level is abstract reasoning and abstract symbolic knowledge. These levels develop simultaneously but with one dominant at any time. Battista (2007) presented an expanded description of the levels, including at level 2 sublevels of visual-informal componential reasoning allowing for description of “parts and properties of shapes informally and imprecisely” (p. 851) and informal and insufficient-formal componential reasoning where students use some formal descriptions which are “insufficient to completely specify shapes” (p. 851) leading to sufficient formal property-based reasoning, which is the original level 2 where students

...explicitly and exclusively use formal geometric concepts and language to describe and conceptualize shapes in a way that attends to a sufficient set of properties to specify the shapes (p. 852).

This structure is supported by the earlier work of Clements, Swaminathan, Hannibal and Sarama (1999) who investigated young childrens’ identification of shape. They found that the children scored highly on the identification of circles, could identify most squares but had more difficulty identifying triangle and rectangle. Older children were more likely to include all the triangles but also more likely to include shapes with curved sides. While the children were operating generally at a visual reasoning level, elements of descriptive analytic reasoning were present with the children’s use of some properties of shape. They focussed particularly on pre-school and grade 0. In extending these ideas, this study takes the identification of triangles through the following four years of school.

Making connections between mental representations of a mathematical concept, creating a network, is one way of viewing understanding (Hiebert and Carpenter, 1992). Since these representations are internal assessment of understanding requires careful thought. One approach is to analyse the student errors and to investigate connections the students make between diagrams, symbols and language. The interview provides an approach to assessment which enables errors to be explored, particularly with young children where other approaches may be limited by literacy.

## **THE STUDY**

During a seven year period a group of 323 students participated in an assessment interview at least once a year as part of the Early Numeracy Research Project (ENRP) and its follow on project (Clarke, Clarke, & Horne, 2006). This group will be referred to as ENRP. One of the tasks used on six of those occasions, during a four year period, was a task requiring identification of triangles from a sheet of triangular shapes loosely based on the material used in the study by Clements et al (1999) but not identical. The students were shown a sheet of nine triangular shapes containing five triangles and four non-triangles which were triangular shapes, as in Figure 1. They were asked to identify which of the shapes were triangles, explain their reasoning and then, in particular, explain their answers for two of the non-triangles.

Figure 1 also shows the text for the interview. The italics indicate what the interviewer is to do while the normal text indicates what is said.

	<p><b>49) Choosing Triangles</b>  <i>Place the blue A4 sheet with the variety of shapes on the table.</i>  a) Please point to the shapes one at a time that are triangles.  b) How do you decide whether a shape is a triangle or not? . . . Is there anything else you want to tell me?  <b>Only ask part (c) if the child correctly identified <u>all</u> the triangles in parts (a) and (b).</b>  <b><i>These should be 1, 4, 6, 8, 9.</i></b>  c) Can you explain how you knew “number 2” wasn’t a triangle. . . . What about “number 3?”</p>
--	---

Figure 1. Task and text used.

This question was asked of the students near the beginning and end of the school year during grades one and two and near the end of the year during grades three and four.

The teachers who taught these children during grades one and two had participated in the ENRP. During these two years there had been professional development about the teaching of geometry and about the development of concepts such as triangle. There was no related professional development for the teachers of grades three and four although it might be expected that they had gained some knowledge through the participation of their colleagues during the previous two years.

As well as this sizable longitudinal cohort of the ENRP, a smaller group of 20 children chosen randomly in one school at each of pre-school and grades zero to eight were asked to make the same triangle identification. The teachers of grades zero to three in this school had had some professional discussion within the school about the teaching of such geometric concepts as were involved in the ENRP but had not been involved in extensive professional development and had not made the teaching of geometry a priority.

## RESULTS AND DISCUSSION

The percentage of students correctly identifying all of the triangles is shown in Table 1 along with the mean score for the nine triangles beneath.



Percentage (Mean score)	Pre	Gr 0	Gr 1	Gr 2	Gr 3	Gr 4	Gr 5	Gr 6	Gr 7	Gr 8
ENRP yr start			3 (5.7)	21 (6.8)						
yr end			15 (6.6)	47 (7.7)	44 (7.8)	50 (7.9)				
School	0 (4.9)	0 (5.4)	0 (5.7)	0 (6.3)	20 (6.5)	60 (7.6)	70 (8.3)	50 (7.8)	75 (8.6)	75 (8.4)

Table 1. Percentage correctly identifying all triangles

From this data it appears that, in the ENRP, grade 2 made an impact on the understanding of the concept of triangle while in the other school it was grade four where the concept was given attention. This percentage data assumes the complete identification of the five triangles and the exclusion of those four triangular shapes which are not triangles. Figures 2 and 3 show the same data graphically including lines indicating students who made up to one error, two errors or three errors.

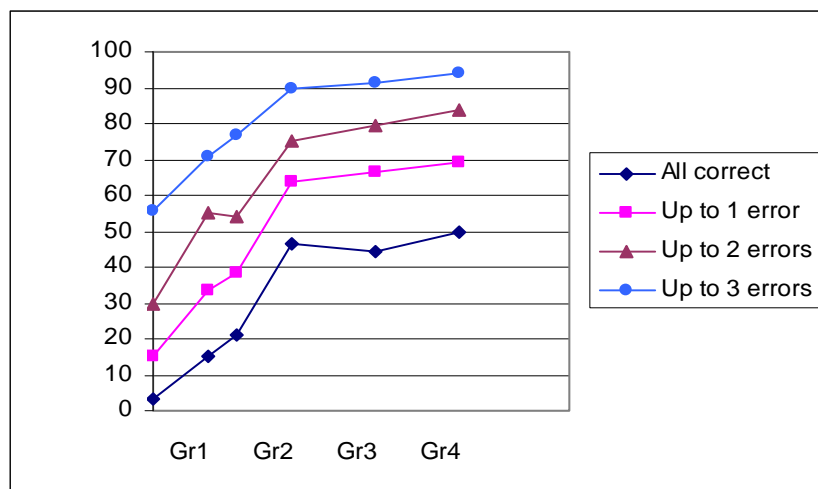

Figure 2. Percentage of ENRP students at each level.

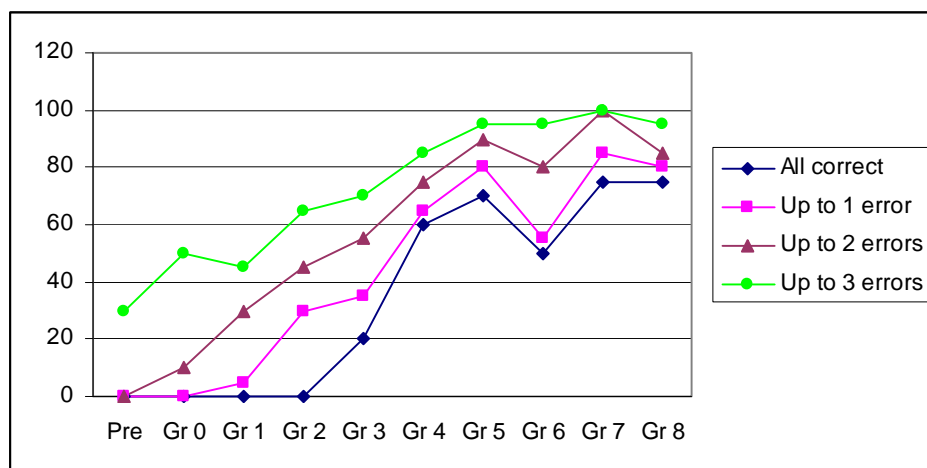

Figure 3. Percentage of students in the school at each level.

Both graphs indicate a fairly steady improvement over the first years, to the end of grade 2 in the ENRP and to the end of grade 5 in the school, followed by a stabilising period with only a small improvement. This suggests that while maturation is a part of the process of the development of the concept, teaching and the focus of the curriculum also has an impact.

The curriculum document states “At Level 1 [grade 0], students ... identify basic two-dimensional shapes such as triangles, circles and squares and three-dimensional solids and objects such as boxes and balls” (Victorian Curriculum and Assessment Authority (VCAA), 2006, p. 2). During grades one and two the standards include “identification of the important features of two-dimensional shapes and use of these distinguishing features to compare and contrast various shapes” (p. 4). At level 2 (end of grade 2) identification of shape includes aspects such as corners and boundaries, the 2D shapes are extended to include rectangles, rhombuses and hexagons; the idea of subsets is raised, and classification of 3D shapes and objects is included. At Level 3 (grades 3 and 4), students recognise and describe the directions of lines as vertical, horizontal or diagonal, recognise angles are the result of rotation of lines with a common end-point and recognise and describe polygons. Developing level 4 (grades 5 and 6) students demonstrate “classification and sorting of two-dimensional shapes using the properties of lines (curvature, orientation and length) and angles (less than, equal to, or greater than  $90^\circ$ )” (VCAA, 2006, p. 14). As can be seen the curriculum works towards the students having a descriptive verbal knowledge and descriptive-analytic reasoning by the end of grade six.

The textbooks that are used reflect the wording of the curriculum, identify the simple 2D shapes in grades 0-2 and include work on polygons lines and angles in grades 3 and 4. However, while the concept of triangle is included at grades 0-2, it seems to be assumed that after that, students understand the concept of triangle (Horne, 2002).

Overall more of the errors were made by including triangular shapes which were not triangles rather than omitting triangles. Table 2 shows the errors split by type.

% of total errors	Omitting triangles	Including non-triangles
ENRP	33.3	66.7
School	26.2	73.8

Table 2. Comparison of errors of omission and inclusion

Clearly inclusion errors are greater than omission errors. The reasons for this may be inferred from the actual errors made. The graphs in Figure 4 show the percentage of children correctly including or excluding each of the shapes in their identification of triangles.

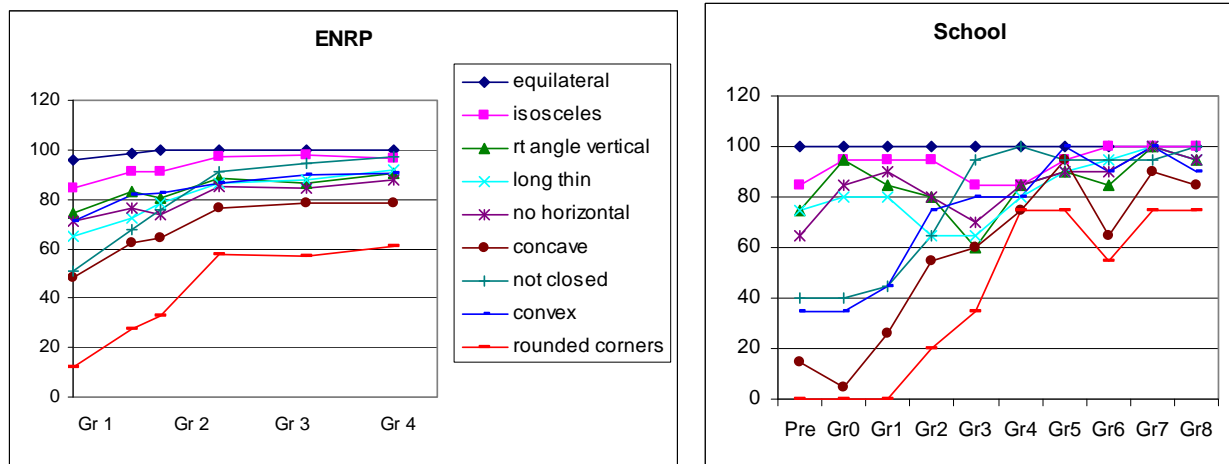

Figure 4. Percentage of children excluding specific shapes.

The first step in the understanding of triangle for these children was the recognition that an equilateral triangle with a horizontal base is a triangle, with all children in the ENRP by the start of grade two and all in the school from the preschool up recognising it as a triangle. The next inclusion generally was the isosceles triangle, also presented in a prototypical manner with a horizontal base, with 97% ENRP including it by the end of grade two. The right angle triangle in a typical presentation with a horizontal and vertical was next with 74% at the start of grade one and 90% at the end of grade four (ENRP) closely followed by the scalene triangle on a horizontal base though over 10% of children at the end of grade four in both the ENRP and the school still did not include these two. The most difficult inclusion was the long thin triangle with only 65% including it at the start of grade one improving to 87% by the end of grade two ENRP. The students in the school at preschool level had very similar inclusion patterns to the students at the start of grade one in the ENRP. Young children learn about shape from their experiences with children’s toys and books, media which tend to present the shapes in narrow ways (Clements and Sarama, 2007). Most triangles are equilateral, or isosceles which are close to equilateral. When a right angle triangle is used it is usually presented in an orientation which includes a horizontal and a vertical and is close to the standard 60° triangle. These experiences guide the children’s attention. Since the shapes were all triangular shapes it would be expected that visual recognition would lead to them being included. The ones closest to equilateral would be included first and this was the case. The language the children used about their reasons for choice included the idea of three sides or three points well before the five triangles were identified showing that in spite of aspects of their knowledge their attention was still governed by limited visual images. Some were using visual-informal componential reasoning. Many of the students who rejected triangles verbally claimed they knew the triangles because they had “three sides”, “the pointy bit points up” or they “look like a roof”. Some who rejected a triangle at grade four included in their description of a triangle the idea of equal length and some described it as “looking like” a pyramid. Another error was the idea that the point had to be at the top. There were some of the students

at a number of grade levels, including grade four, who described a triangle as having three points and three sides but who rejected the long thin triangle.

Generally inclusion of all triangles develops before exclusion of triangular shapes which are not actual triangles. This is related to a move from the visual holistic concept at level 1 of van Hiele and the related recognition of attributes such as three sides or three points, to level 2 of van Hiele where a property and then properties of triangles are identified. The first triangular shape to be correctly excluded as a triangle was the convex shape with 71% excluded it at the start of grade 1 increasing to 90% by the end of grade 4 (ENRP). Many of the children rejecting this shape specified straight sides but still accepted another shape with concave sides. These students were using informal and insufficient formal componential reasoning.

The requirement of closure was the next to be accepted as part of the triangle concept starting with 51% at the start of grade one and reaching 97% by the end of grade four (ENRP). In the school the figure for pre-school to grade one was 40% but 100% by the end of grade four. Rejecting both the shapes with curved sides showing an increased understanding of the idea of straight sides was next though by the end of grade four there were still over 20% of the children still including the concave shape.

The last aspect to be recognised was the nature of a “point” or “corner”. Nearly 40% of the grade four children still had not understood that the corners could not be rounded but indeed needed to be points with the two straight edges meeting, an improvement from the 12% at the start of grade one but little improvement from the end of grade two (ENRP). 25% of grades seven and eight were still incorrectly accepting it as a triangle. There may be a number of reasons why this shape is often identified as a triangle. Children’s previous experiences may cause them to attend to other aspects although they are also attempting to use properties. This is a shape often in toys for young children where the corners have been rounded to avoid injury. Children sometimes draw around shapes as templates and this means the drawings will have rounded corners. The visual image presented by this shape is also very similar to the equilateral triangle, the first recognised triangle. Finally it is the same shape as the musical instrument called a triangle.

It is clear that children’s experiences both out of school in the early years and in school affect their development of the concept of triangle and the aspects of shape to which they attend. The differences in the year where the greatest change occurred (grade 2 in the ENRP and grade 4 in the school) is related more to the attention given to the development of shape concepts in the curriculum. Verbal acknowledgement of the properties of a shape is not sufficient for children to attend to those properties when classifying or using shape. Teachers need to find ways to focus children’s attention and to ensure they have the experiences upon which to build the connections between the concepts. Students in the upper elementary grades also need attention to the connections between the properties and the corresponding experiences to assist in their development of the concept of triangle and other shapes.

The data also supports Battista's (2007) expanded description of the van Hiele levels.

### Endnote

The ENRP was a project based at the Mathematics and Literacy Education Research Flagship at Australian Catholic University. All of the researchers involved in the ENRP contributed to the data on which this study is based. The follow up longitudinal study was also based in the Research Flagship.

### References

- Battista, M. T. (2007). The development of geometric and spatial thinking. In F. K. Lester (Ed.), *Second Handbook of Research on Mathematics Teaching and Learning*. Charlotte, NC: NCTM.
- Clarke, B., Clarke, D., & Horne, M. (2006). A longitudinal study of children's mental computation strategies. In J. Novotná, H. Moraová, M. Krátká, & N. Stehliková (Eds.), *Mathematics in the Centre. Proceedings of the 30<sup>th</sup> Conference of the International Group for the Psychology of Mathematics Education* (Vol 2, pp. 329-336). Prague: Charles University.
- Clarke, D., Cheeseman, J., Gervasoni, A., Gronn, D., Horne, M., McDonough, A., Montgomery, P., Roche, A., Sullivan, P., Clarke, B., & Rowley, G. (2002). *Early Numeracy Research Project: Final report*. Melbourne: Australian Catholic University and Monash University.
- Clements, D. H. & Battista, M. T. (1992). Geometry and spatial reasoning. In D. A. Grouws (Ed.), *Handbook of research on mathematics teaching and learning* (pp. 420-464). New York: Macmillan
- Clements, D. H. & Sarama, J. (2007). Early childhood mathematics learning. In F. K. Lester (Ed.), *Second Handbook of Research on Mathematics Teaching and Learning*. Charlotte, NC: NCTM
- Clements, D. H., Swaminathan, S., Hannibal, M. A. Z., & Sarama, J. (1999). Young children's concepts of shape. *Journal for Research in Mathematics Education*, 30(2), 192-212.
- Hiebert, J. & Carpenter, T. P. (1992). Learning and teaching with understanding. In D. A. Grouws (Ed.), *Handbook of Research on Mathematics Teaching and Learning* (pp. 65-97). New York: Macmillan
- Horne, M. (2002). Properties of shape. In M. Goos and T. Spencer (Eds.), *Mathematics: Making Waves* (pp. 120-128). Adelaide: The Australian Association of Mathematics Teachers Inc. Reprinted (2003) *Australian Primary Mathematics Classroom* 8(2), 8-13.
- Victoria Curriculum and Assessment Authority (2006). *Mathematics: Standards and Progression Points*. Melbourne: VCAA. Retrieved December 14, 2007 from <http://vels.vcaa.vic.edu.au/assessment/ppoint/maths/index.html>

# COMPARISON OF BLACK-BOX, GLASS-BOX AND OPEN-BOX SOFTWARE FOR AIDING CONCEPTUAL UNDERSTANDING

Anesa Hosein, James Aczel, Doug Clow, and John T.E. Richardson

The Open University

*Three mathematical software types: black-box (no steps shown), glass-box (steps shown) and open-box (interactive steps) were used by 32 students to solve conceptual and procedural tasks on the computer via remote observation. Comparison of the three software types suggests that there is no difference in the scores that students receive for conceptual understanding tasks. Students using the black-box are more likely to explore answers than students using the glass and open-box software.*

## INTRODUCTION

Various mathematical software types such as spreadsheets, CAS or graphic calculators are used at the undergraduate level. These types of software usually function as a black-box (Buchberger, 1990), that is, students input the equations or numbers and through an execute command they receive the answers without seeing the intermediate steps. Whilst the black-box has been applauded in easing the anxiety of weak mathematical students and allowing students to use complex problems, there is concern whether black-box software is the most appropriate tool for students since they are unaware of the processes and have to accept the outputted (Heid and Edwards, 2001). Buchberger (1990; 2002) suggests that it may be appropriate for some students to use glass-box software which enables the students to see each & before the answer is produced. There is a third type of software that students may use and referred to in this paper as open-box software. Open-box software is where students are able to interact at each step during the solving of the software until the answer is determined. Figure 1 illustrates the three types.

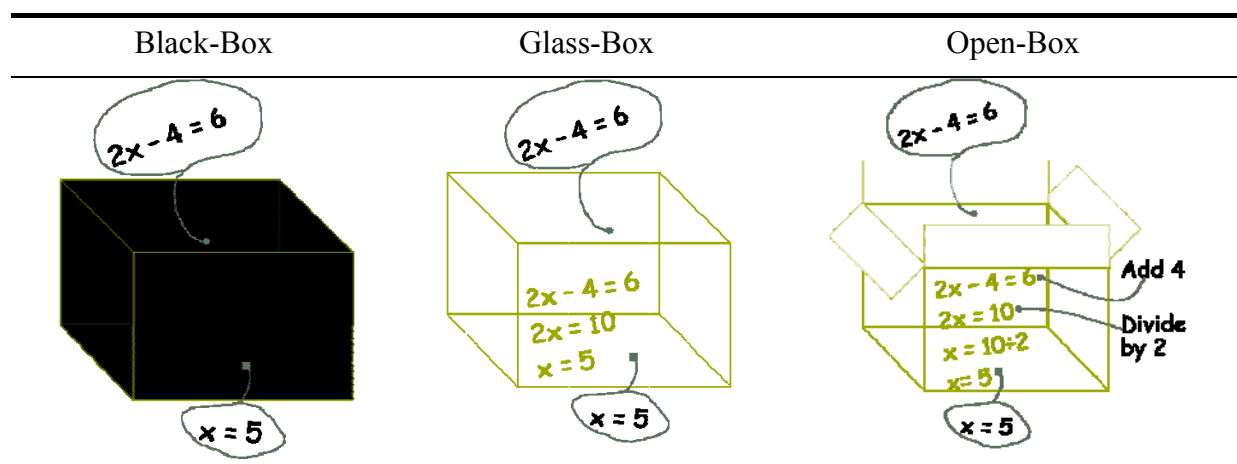

Figure 1. Comparison of an algebra solution by black-box, glass-box and open-box.

There are limited studies in the comparison of the three software types. For example, Horton, Storm, & Leonard (2004) compared the Texas Instruments TI-83 (black-box) and the Casio FX (glass-box) graphing calculators. In their study, over a three week period college students were given problems to solve either in a TI-83 or a Casio FX calculator. At the end of three weeks, students were given a pen-and-paper test and they found that students who used the Casio FX outperformed the students using the TI-83. However, their study looked at only the improvement on mechanical or procedural skills and gave no indication whether the software helped in conceptual understanding. Further, their study measured symbolic manipulation by hand, and whilst this is important, at the tertiary level students are often required to solve problems using software or calculators and such workings have become trivialised.

Perhaps, it may be more appropriate to compare and determine whether these three types of software may have additional advantages over each other such as improving conceptual understanding. Thus, this study investigates how the three software types influences the mathematical understanding of students.

## **METHODOLOGY**

Whilst Horton et al. (2004) only investigated the mechanical or procedural understanding of the students, this research goes further to investigate whether there is any improvement in their conceptual understanding. Thus, a mathematical question taxonomy used by Galbraith and Haines (2000) was employed. They identified three questions types: mechanical, interpretive and constructive. Mechanical questions are mostly related to procedural knowledge, interpretive questions mostly to conceptual knowledge, and constructive questions a mixture of both conceptual and procedural knowledge. Three problems were developed in the linear programming domain which had three parts relating to each of these question types (see Table 1). Linear programming was chosen since a complex problem was needed that students were not familiar with at the tertiary level and could not be easily solved by hand. All mechanical questions were required to be solving used the software. The interpretive questions required the student to either examine or interpret the solution or the problem. The constructive questions had two parts, the first part required the student to use mostly procedural skills to find a different solution for the problem and the second part to use mostly conceptual knowledge to indicate why the different solution worked. All constructive questions were designed to allow the students to solve the procedural part either by using the software or by pen/paper that is through the examination of the problem.

Finding a similar software that displayed all three software types characteristics for linear programming (or for any other mathematical problem) was unsuccessful. Thus, the simplex algorithm used in linear programming was programmed in MS Excel using Visual Basic Application (VBA) to mimic the characteristics of the black-box, glass-box and open-box. As the simplex algorithm involves several choices during an iteration (for example choosing a pivot variable, determining the ratio, choosing pivot

row), the students using the open-box were only required to determine the pivot variable for each step. For all software, the students were aware of when the problem was solved as a pop-up box will indicate that the best solution was found.

Linear Programming Problem:	
a) Solve	
Max $2x_1 + x_2$	
$2x_1 + x_2 \leq 100$	(constraint A)
$x_1 + x_2 \leq 80$	(constraint B)
$x_1 \leq 40$	(constraint C) <b>(Mechanical)</b>
b) If $x_1 =$ no. of toy trains manufactured and $x_2$ refers to the no. of toy soldiers manufactured, and constraint A refers to painting hours, constraint B to carpentry hours and constraint C, the demand for toy trains. Interpret what this solution means to the toy company who wants to maximize their profit by producing toy trains and toy soldiers. Provide as detail answer as possible.	<b>(Interpretive)</b>
c) If the profit of trains has increased by £1, how would this affect the number of toy trains and toy soldiers being sold? Provide as detail as an answer as possible.	<b>(Constructive)</b>

Table 1. Illustration of a linear programming problem with the three question types

Data was collected for 36 university students in the UK and Trinidad and Tobago. Students were observed in individual sessions using remote observation (see Hosein, Aczel, Clow, & Richardson, 2007). In the remote observation method data is collected via the internet where students connect to the researcher’s computer and uses software on the researcher’s computer through application sharing (Figure 2) thus making it practical for collecting data from these two countries.

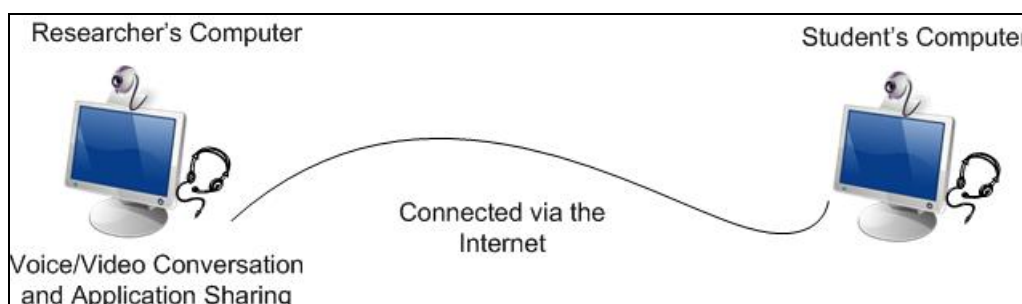

Figure 2. Remote observation process.

The observation session was modified from the quasi-experimental framework of Renkl (1997) and Große & Renkl (2006) by adding on the approaches to study



inventory (see Table 2Table ). This method was chosen in order to collect both quantitative and qualitative data to allow triangulation. Further, it ensured that data from the software and the questions types could be partitioned to determine if there were any significant differences.

Students were randomly assigned to use one of the software types to answer all three problems within a Latin square design. Quantitative data was collected from the background questionnaire, pre-test, post-test and the approaches to study inventory. During Step 4, the experiment, students were able to practice with their randomly assigned software and then proceeded to do the three linear programming problems. Their answers were typed and recorded in an answer sheet created in MS Excel. Whilst solving these three problems, students were encouraged to think aloud (Ericsson & Simon, 1984). The think-aloud protocol was used to elicit what self-explanations students were using (Chi, Bassok, Lewis, Reimann, & Glasser, 1989). Students use of the software and their working environment were video recorded from the application sharing process and webcams respectively.

Steps	Instructions
1. Background Questionnaire	Students are asked to fill in a demographic questionnaire, including questions asking for mathematical level, age and gender
2. Study Materials	Students peruse materials to understand the fundamental concepts required for the learning of the topic
3. Pre-test	Students to determine what extent they have prior knowledge of the topic before the stimulus is provided for the experiment. The pre-test problems is at a lower difficulty level than the post-test problems
4. Experiment	Students are provided with the interventions/ factors that are being studied (the type of software)
5. Post-test	Students work on a set of questions to acquire quantitative data to compare the investigated interventions/ factors
6. ASI	Students filled in an approaches to study inventory (ASI) to determine whether a surface or deep approach was used.

Table 2. Modified Quasi-Experimental Method

This paper presents the post-test results for 32 students, 11 using black-box and glass-box each and 10 using the open-box software. For each of the three problems, the students were scored 1 mark for the mechanical part and 2 marks each for the interpretive and constructive part. In this paper, the explanations that students typed for the interpretive and constructive parts were coded into whether the students were relating their explanations to real-life applications and/ or mathematical knowledge. These explanations were part of the students’ think-aloud self-explanations. The coding chosen was used to help determine how students were linking their knowledge.

## RESULTS AND DISCUSSION

### Post-Test Total Mean Scores

The mean scores for each of the software are presented in Table 3. Using an ANOVA, it was found that there was no significant difference in the mean scores from the three software types. All the students achieved full marks for the mechanical part of the problem as was expected since all the students had to use the software to solve the problem. Thus, if there was any significant difference this would have been to the mean scores relating to conceptual understanding. These results perhaps suggest that the three boxes may not improve the conceptual understanding of the students differently.

Software Type	Mechanical	Interpretive	Constructive	Total
Black-Box (11)	3.00	2.96	1.73	7.68
Glass-Box (11)	3.00	2.82	0.95	6.77
Open-Box (10)	3.00	2.95	0.85	6.80
Mean (32)	3.00	2.91	1.19	7.09

Table 3. Score means for the types of questions for the three software types

Students received an average score of 48.5% for interpretive tasks and 19.8% on the constructive tasks. Further examining the constructive tasks, if the constructive tasks were partitioned into its two parts, the students who were able to calculate the procedural part were approximately 30% likely to give a reasonable conceptual explanation for why the procedural part worked (Table 4).

Software Type	Constructive (Procedural)	Constructive (Conceptual)	Constructive (Total)
Black-Box (11)	1.32	0.41	1.73
Glass-Box (11)	0.77	0.18	0.95
Open-Box (10)	0.65	0.20	0.85
Mean (32)	0.92	0.27	1.19

Table 4. Score means for parts 1 and 2 of the constructive problems for the three software types

Further, from an ANOVA, the means suggest that there may be a weak association ( $p < 0.1$ ) between the software types and the procedural part of the problem. That is, students using the black-box software appeared to receive scores almost twice those of the students using the glass-box and open-box software in the procedural part of the constructive problem. Whiteman & Nygren (2000) have suggested that black-box software types are useful tools for exploration: that is, for students inputting values and looking at trends. Perhaps students who used the black-box software for exploration in the procedural section of the constructive problems were able to do better. As such, the video data was examined to determine whether students explored

using the software for the constructive problem. Those students who explored were coded “yes” for exploration and “no” for no exploration. Although a chi-square suggests that there was no significant difference in the frequency of exploration for the constructive question by software, the data suggests that students using the black-box (73%) and the glass-box software (64%) had a higher frequency of exploring the constructive task than the open-box (40%).

Further, looking at how students did on the constructive problem on whether they explored or did not explored regardless of the software, it was found that students who did explored, significantly outperformed ( $p < 0.01$ ) students who did not explore (1.76 vs 0.35, see Table 5).

Constructive Explored	Constructive (Procedural)	Constructive (Conceptual)	Constructive Score	Total Score
No	0.35	0.00	0.35	6.23
Yes	1.31	0.45	1.76	7.68
Mean	0.92	0.27	1.19	7.09

Table 5. Mean scores for the constructive questions depending on whether the students explored using the software

Further, only students who were able to explore using software to determine the procedural part (unlike those with pen-and-paper) were able to provide a reasonable conceptual explanation. These results imply that although students were able to solve the procedural part either by hand or software, those who did get it correct were more likely to use the software rather than by hand. Further, there was no guarantee that if the students used the software to explore that they were able to obtain the procedural answer, as the average percentage score was approximately 44%.

### Explanations of problems

Perhaps further light can be shed on why students did poorly if the explanations can be examined. Coding the explanations from the interpretive and constructive tasks into real-life explanations and mathematical explanations, the results indicate that the students use mathematical and real-life explanations almost equally (Table 6).

	Mathematical Explanations	Real-Life Explanations	Total Explanations
Black-Box (11)	2.6	1.9	4.5
Glass-Box (11)	1.4	2.3	3.7
Open-Box (10)	2.5	1.6	4.1
Total (32)	2.2	1.9	4.1

Table 6. Mean number of explanations that students use for each software box

An ANOVA indicated that there was no significant difference in the mean number of explanations that students used depending on the software, although examining the data there seems to be less mathematical explanations from students using the glass-box software. Examining the conceptual explanations provided for the constructive tasks, there is a clearer indication why students were doing badly in this problem. There were two main reasons, firstly that students who related their explanations to real-life tended to ignore the underlying mathematics as it relates to the problem (see Table 7). Further, students who used mathematical explanations were sometimes bad at algebra such as understanding the difference between a variable and a coefficient.

*“If the profit per train increased, this means the price of the train increased, if the price of the train is higher than the price of the soldiers, consumers would more likely purchase the cheaper item”* (Glass Box: Real-Life Explanation - ignoring underlying mathematics that  $x \leq 40$ )

*“Increase profit by £1 may change constraint C to  $x \leq 40 + 1$  and since  $x = 40$  was our previous answer this may mean it would now mean  $x$  increases and  $y$  decreases”* (Open Box: Mathematical Explanation - students is changing the right hand side of the equation rather than the coefficient)

*“Profit would increase to 140 but the numbers of toys made stays the same because constraints is that  $x = 40$  maximum so even though they get more profit they cant make any more trains”* (Black-Box: Mathematical Explanation - correct explanation)

Table 7. Examples of real-life and mathematical explanations made by students for the constructive problem

Also, for the constructive problems, the students who explored using software were significantly likely ( $p < 0.05$ ) to give a mathematical explanation than those who did not (1.7 vs 0.9). Students who used real-life explanation gave a similar number of self-explanations whether they explored with software or did not (1.2 vs 0.9). Examining further to determine whether there is any influence from the software types, the type of explanations given for the constructive problems seem to be weakly associated with software type ( $p < 0.1$ ). Students using the black-box (1.73) and the open-box (1.5) had a higher mean number of mathematical explanations than that from the students using the glass-box software (0.91). A simple correlation between the scores made for the constructive problem and the types of explanations made found that mathematical explanations positively correlated ( $r = 0.62$ ,  $p < 0.01$ ) with the mean constructive whilst the real-life explanations were negatively correlated ( $r = -0.37$ ,  $p < 0.05$ ) with the mean constructive scores. This suggests that students who understood the problem mathematically were able to perform better and possibly is dependent on the software.

## CONCLUSION

This paper has shown that students using any of the three software types can receive the same mean scores in problems associated with conceptual understanding.

However, students using the black-box software are probably more likely to explore numbers and solutions and this may be due to its nature in allowing students to quickly get an answer. Further, students using the black-box and open-box were more likely to give mathematical explanations to conceptual problems than the glass-box which ensured that they did better overall. Whilst mathematical explanations were expected to be frequent in the open-box and glass box as steps are shown, perhaps the reasoning for the glass-box software having low mathematical self-explanations may be due to the mathematical ability of the students which would have to be further explored.

## References

- Buchberger, B. (1990). Should students learn integration rules? *ACM SIGSAM Bulletin*, 24(1), 10-17.
- Buchberger, B. (2002). Computer algebra: the end of mathematics? *ACM SIGSAM Bulletin*, 36(1), 16-19.
- Chi, M. T. H. C., Bassok, M., Lewis, M. W., Reimann, P., & Glaser, R. (1989). Self-explanations: how students study and use examples in learning to solve problems. *Cognitive Science*, 13(2), 145-182.
- Ericsson, K. A. & Simon, H. A. (1984). *Protocol Analysis: Verbal Reports as Data*. Cambridge, MA: MIT Press.
- Galbraith, P. & Haines, C. (2000). Conceptual mis(understandings) of beginning undergraduates. *International Journal of Mathematical Education in Science and Technology*, 31(5), 651-678.
- Große, C. S. & Renkl, A. (2006). Effects of multiple solution methods in mathematics learning. *Learning and Instruction*, 16(2), 122-138.
- Heid, M. K. & Edwards, M. T. (2001). Computer algebra systems: revolution or retrofit for today's mathematics classrooms?. *Theory Into Practice*, 40(2), 128-136.
- Horton, R. M., Storm, J., & Leonard, W. H. (2004). The graphing calculator as an aid to teaching algebra. *Contemporary Issues in Technology and Teacher Education*, 4(2), 152-162.
- Hosein, A., Aczel, J., Clow, D., & Richardson, J. T. E. (2007). An illustration of student's engagement with mathematical software using remote observation. In J.-H. Woo, H.-C. Lew, K.-S. Park, & D.-Y. Seo (Eds.), *Proceedings of the 31st Annual Conference of the International Group for the Psychology of Mathematics Education (PME 31)* (Vol. 3, pp. 49-56). Seoul, Korea.
- Renkl, A. (1997). Learning from worked-out examples: A study on individual differences. *Cognitive Science*, 21(1), 1-29.
- Whiteman, W. E. C. & Nygren, K. P. C. (2000). Achieving the right balance: properly integrating mathematical software into engineering education. *Journal of Engineering Education*, 89(3), 331-336.

# DEVELOPING RELATIONAL THINKING IN AN INQUIRY ENVIRONMENT

Jodie Hunter and Glenda Anthony

Massey University

*Student transition from arithmetic to algebraic reasoning has been recognised as an important but difficult process. The concept of equivalence and relational understanding of the equal sign are fundamental to algebraic understanding. Drawing on findings from a classroom-based study, this paper examines how instructional tasks, specific pedagogical actions, and classroom settings can support students to develop deeper understanding of relational equivalence and relational strategies. The results suggest that student use of relational strategies can be facilitated through the use of purposely designed tasks and specific teacher actions.*

## INTRODUCTION

The teaching and learning of algebraic reasoning has received increased research and curricula attention in recent years (e.g., Knuth, Stephens, McNeil, & Alibabi, 2006; Ministry of Education (MoE), 2007; National Council of Teachers of Mathematics (NCTM, 2000). Driving this focus is the growing acknowledgement of the many students who complete schooling with poor algebraic understanding and the role this has in denying them access to potential educational and employment prospects (Knuth et al.). In response, many researchers and policy makers (e.g., Carpenter, Franke, & Levi, 2003; NCTM; MoE) advocate integrating the teaching of arithmetic and algebra as a unified curriculum strand. Within this strand, the combination of students' informal knowledge and numerical reasoning can be used to transition early algebraic thinking. Essential to the transition is a requirement that students understand the equal sign as a representation of an equivalence relationship and that they are able to use this understanding to work flexibly with numbers. Whilst many studies have reported on student misconceptions related to the equal sign, there appears to be less research available on the specific instructional tasks and pedagogical actions which support student development of relational strategies and understanding of relational equivalence. The research reported in this paper examines the instructional tasks and pedagogical actions a teacher used with a class of nine to eleven year olds in order to shift them towards more sophisticated understanding of relational equivalence and relational strategies as a foundation for early algebraic reasoning.

Conceptual understanding of the equal sign as a symbol of equivalence or quantitative sameness is essential for student transition to algebraic reasoning (Knuth et al., 2006). In her seminal study, Kieran (1981) linked an inadequate understanding of the equal sign to students' difficulties in solving symbolic expressions and equations. The strategies available to solve equivalence problems are limited when students equate the equal sign with carrying out an operation, finding a 'sum' or

'answer', or a left to right action of adding all the numbers (Carpenter, Levi, Franke, & Zeringue, 2005). However, for those students who understand the symbol as quantitative equivalence further strategy differentiations are evident. One group use computational reasoning. These students consider the numbers on each side of the equal sign as separate calculations and so compute to solve equivalence problems (Carpenter et al., 2003; Stephens, 2006). The other group use relational forms of thinking to examine the "expressions in their entirety, noticing number relations among and within these expressions and equations" (Jacobs, Franke, Carpenter, Levi; & Battey, 2007, p. 260). That is, they use number relations to simplify calculations.

Stephens (2006) maintains that relational thinking is dependent on whether students are able to flexibly identify and use a range of possibilities of variation between numbers within number sentences. If so, these students would likely consider the expression on both sides of the equal sign, and use the relationship between the expressions without needing to calculate. To ensure relational reasoning is developed advocates (e.g., Carpenter et al., 2005; NCTM, 2000; Warren, 2007) promote instruction that provides opportunities for young learners to integrate arithmetical and algebraic reasoning. They suggest providing students with learning situations which incorporate instructional tasks and inquiry discourse to challenge student concepts of equality and press them to consider equivalence relationships. Stephens goes further, arguing the need for explicit teaching of relational approaches if students are to shift beyond the use of computational approaches. Based on this recommendation, the reported classroom study examined how one teacher within an inquiry environment effectively used instructional tasks and explicit pedagogical actions to scaffold young students' use of sophisticated forms of relational reasoning.

The theoretical stance taken in this study is within the emergent perspective taken by Cobb (1995). Within this socio-constructivist learning perspective Piagetian and Vygotskian notions of cognitive development connect the person, cultural, and social factors. In this perspective, the learning of mathematics is considered not only as an individual constructive process but also a social process involving social negotiation of meaning.

## **METHOD**

The research reported in this study was conducted at a New Zealand urban primary school and involved 25 students aged 9-11 years. The students were from predominantly middle socio-economic home environments and represented a range of ethnic backgrounds. The episodes described in this paper are drawn from a larger study involving a 3-month classroom teaching experiment (Cobb, 2000) situated in an inquiry classroom environment.

A collaborative teacher-researcher partnership was formed and supported through the use of a teaching experiment approach. All students participated in pre- and post-interviews. Data gathered from the pre-interview was used to develop a hypothetical learning trajectory and inform the development and selection of instructional tasks

designed to develop early algebraic understanding. Data was generated and collected through participant observations, video recorded observations, classroom artefacts and pre and post interviews.

On-going and retrospective data analysis was used to develop the findings of the one classroom case study. The study was shaped by on-going data analysis as the researcher and teacher collaboratively examined the classroom practices, modified the instructional sequence and amended the associated learning trajectory. Retrospective data analysis took a grounded approach to identify categories, codes, patterns, and themes.

On-going and retrospective data analysis was used to develop the findings of the one classroom case study. The study was shaped by on-going data analysis as the researcher and teacher collaboratively examined the classroom practices, modified the instructional sequence and amended the associated learning trajectory. Retrospective data analysis took a grounded approach to identify categories, codes, patterns, and themes.

## RESULTS AND DISCUSSION

This section presents pre- and post-test results to illustrate the shifts in the participant students' use of relational strategies. Table 1 overviews the number of students using relational reasoning at the first interview at the start of the classroom study.

	Relational strategy	Computational strategy	Error or no response
A) $27 + 16 = \_ + 14$	20%	12%	68%
B) $54 + \_ = 57 + 36$	24%	8%	68%
C) $84 - 18 = 86 - \_$	20%	16%	64%

Table 1. Percentage of students (n=25) using relational or computational strategies

In Table 2 the proportion of students using relational reasoning at the final interview is documented.

	Relational Strategy	Computational strategy	Error or no response
A) $23 + 15 = \_ + 17$	68%	28%	4%
B) $81 + \_ = 83 + 26$	84%	12%	4%
C) $76 - 27 = 78 - \_$	84%	12%	4%

Table 2. Percentage of students (n=25) using relational or computational strategies



In the final interview all students provided relational explanations for the equal sign. To explain their reasoning they drew on explanatory justification which had been modelled and appropriated in the classroom discourse. The considerable increase in the number of students able to use relational strategies along with sound explanations, confirmed that the tasks, classroom talk, and pedagogical actions had effectively scaffolded students' use of more flexible relational strategies.

The focus of the research was to examine how such learning was occasioned. In the next section we consider the pedagogical practices-involving a combination of mathematical tasks, tools, teacher scaffolding and inquiry discourse-evidenced in the study.

### **Mathematical tasks and inquiry discourse**

In the first instance the teacher used true and false number sentences. Students working in small discussion groups, comprised of participants holding varying levels of understanding of the equal sign, were required to explain and justify their reasoning. Opportunities to explore the role of the equal sign as they listened to relational explanations effectively scaffolded their understanding of it as quantitative sameness. This was illustrated when Mike explained his reflective shift after a discussion of the sentence  $7 + 5 = 3 + 9$ :

Mike: I thought it was false at first...we kind of thought it was seven plus five equals three, I didn't get the plus nine. Then I found out it was seven plus five equals twelve and then equals three plus nine and it's like what Heath said, equals is the same as.

It was apparent that constructing rich conceptual understanding of the equal sign as a relational concept is a lengthy and complex process. For these learners, understanding was observed to shift backward and forward with evidence of sound understanding seen in the ability to challenge responses. For example, Peter stated that the number sentence  $11 - 4 = 10 - 3$  did not equal ten and Mike responded:

Mike: No it doesn't have to equal ten...is eleven minus four the same as ten minus three? Does eleven minus four equal the same answer as ten minus three? Equals means the same as.

We observed that those students who understood the equal sign as relational equivalence and considered the number sentences as representing two equations separated by the equal sign typically used computation to solve the open number sentence problems. For example, Peter justified  $8 + 6 = 9 + 5$ :

Peter: True...because eight plus six equals fourteen and nine plus five equals fourteen.

Tasks involving equivalence equations which used closely related numbers were introduced so that the students could solve the problems by using the relationship between both expressions without carrying out a calculation. The close sequence of numbers resulted in immediate visual observations of the relationship and eliminated a need to calculate:

Hannah: Eleven minus four is the same as ten minus three...because you're just taking away one more away from the eleven than the ten.

Observations of the difference of one supported students to provide explanatory justification:

Rani: Both of these two numbers they are just one number higher than these ones. If you have a number like twelve minus five and then there was thirteen take away six, they would both be the same and you don't have to subtract the numbers to find out if it's true.

Tasks with larger numbers were then introduced with the ongoing expectation that students provide clear and convincing explanations and that listeners question and clarify until they were convinced. This press resulted in the students providing explicit step-by-step explanations. For example, the explanation given for the solution strategy for  $256 + 3 = 246 + 13$ :

Rani: From the two hundred and forty-six to the two hundred and fifty-six there is ten there and from the three to the thirteen there is ten there as well.

Teacher: Are you adding or subtracting that ten?... Talk to the person next to you about whether or not it is adding or subtracting the ten?

Rani: Subtracting ten and that's adding ten.

Developing relational strategies requires time to develop and shifting back and forward between the use of calculational and relational strategies was not unexpected. At this point in the study the students most often drew on computational strategies to fold back to when they encountered difficulties explaining their reasoning using a relational explanation. For example, although Rachel began with a relational strategy to solve  $583 - 529 = 83 - 29$  the following episode illustrates how a disagreement and challenge was solved within the group by folding back to calculating as part of an alternative explanation:

Rachel: You'd take away the five hundreds...if you look at it carefull...take away the five hundreds on those and then it will be eighty-three take away twenty-nine is the same as eighty-three take away twenty-nine.

Rani: If you take away five hundred and eighty-three from five hundred and twenty-nine it will be a higher number than that...maybe if we took away this first.

Rachel: So you take that away.

Rani: Eighty-three round that and the closest number to that is eighty.

Matthew: The closest number to that is thirty. Eighty minus thirty is fifty.

### **Pedagogical actions to extend relational understandings**

Specific pedagogical actions were important in supporting student use of relational strategies. Within the study, collaborative lesson planning involving discussions that supported the teacher to anticipate likely student contributions increased the teacher confidence to monitor and select specific students to present their mathematical responses to number sentence problems:

Teacher: I want you to think whether there is a way to prove without actually adding up the numbers.

With expectations that students justify their reasoning repeatedly reinforced in whole-class feedback sessions, the teacher used sequencing of student responses to move justification from calculational to relational reasoning:

Teacher: Is there a way that you can show seven plus five is the same as three plus nine without actually adding it up? Just have some thinking time about how you can prove that without actually adding up those numbers.

She explicitly directed attention to examples of efficient relational approaches:

Teacher: So you're telling us that you didn't have to subtract the numbers on both sides? You just looked at the number? Right I want everyone looking at Rani because this is really important.

To make the algebraic reasoning available and accessible to all students the teacher pressed the students to represent their reasoning through invented notation schemes. Initially she notated the relational strategies using arrows as a model for the students.

$$67 + 49 = 69 + [47]$$

Figure 1. Recording relational strategies using arrows.

Representing algebraic reasoning through the use of arrows became an important explanatory tool the students used to clarify and justify their reasoning.

Another important form of representation emerged when a student represented his reasoning for a problem<sup>1</sup> using the image of a scale. The teacher revoiced and appropriated his analogy to enable other students to access the idea of balance. In the open-ended discussion which followed another student used the representation and embedded it in a real-life context to explain relational equivalence:

Stella: If you're minusing from one side on a scale, say there is seven pounds of butter on one side and seven pounds of butter on the other side and you are minusing seven pounds of butter then that does matter because one side will just go down and other side will go up...but if you're minusing from both sides there is not really a point because if you take it both off it will still be equal.

At this point the teacher pressed further towards generalising the concept:

Teacher: If they take it only off one side, the other side is going to tilt one way so it won't be balanced, it won't be equal. So you're taking seven off one side then you have to do exactly the same to the other side to make it equal.

The representation of a balance scale became a consistent means used by the students to justify and convince the listeners:

Ruby: You would have to take-away the same number otherwise it wouldn't be right because one side... using the scale thing it would go down [uses her hands to indicate a balance scale going up and down] because you took away too much from one side and you took away not the right amount from both sides.

The consistent press by the teacher for students to justify and convince all participants through the use of relational strategies resulted in the students' own press

<sup>1</sup> The solution to the equation  $4n + 15 = 47$  is  $n = 8$ . What is the solution to the equation  $4n + 15 - 7 = 47 - 7$ ?

on each other to do likewise. For example, the following exchange centred on the number sentence  $1092 - 56 = 1082 - \_$  illustrates the expectation to be convinced and to be prepared to convince:

Ruby: So that is ten more what you do is...

Heath: If you have to take away fifty-six you just take away fifty.

Ruby: Fifty? Why fifty from that?

Heath: Because you get the fifty out of there, minus that off there equals forty. Forty-two so far minus six equals thirty-six.

Ruby: No wait Heath. No, that is not the point.

Heath: I know what to do... so that is one thousand and thirty-six.

Ruby: But instead of...but Heath what we are trying to do it is, is just look at it and be able to take it away. If you look at it...that side is ten more and that side is ten less. Look it should be 46 because it's ten less.

## CONCLUSION AND IMPLICATIONS

This study sought to explore how students could be supported to develop more sophisticated relational equivalence through specific instructional and pedagogical actions. Developing conceptual understanding of the equal sign as quantitative sameness was the foundation for students constructing and using more flexible relational strategies. The small sample of learning tasks (from a larger set used in the teaching experiment) reported on in this paper supported the contentions of Carpenter and his colleagues (2005) and Stephens (2006). The inquiry environment and tasks involving exploration of equality provided rich sites for student learning. Within the collective discussions cognitive conflict provided a useful starting point of exploration and reflective analysis that prompted students to reconsider their numerical understandings. The repeated use of such tasks over extended time enabled them to construct flexible relational strategies.

In addition to the purposely designed tasks, the teacher's pedagogical actions were central. The embedded norms of student authority and accountability were evident in teacher expectation that students represent their reasoning in a way that is accountable to the discipline (Carpenter et al., 2003). In pressing students to consider a range of strategies the teacher acknowledged the need for students to shift back and forth between calculational and relational thinking. Moreover, the teacher's explicit focus on relational approaches resulted in the majority of her students using relational strategies to solve the equivalence problems as evident in the final post-interview. In supporting students to shift from arithmetic understanding to early algebraic reasoning, the findings from this study affirm the value of instructional practices that place an emphasis on relational approaches. Additionally, the findings affirm the value of inquiry learning environments that attend to individual and collective listening, thinking and argumentation.

## References

Carpenter, T., Franke, M., & Levi, L. (2003). *Thinking Mathematically: Integrating Arithmetic and Algebra in Elementary School*. Portsmouth: Heinemann.

- Carpenter, T., Levi, L., Franke, M., & Zeringue, J. (2005). Algebra in elementary school: Developing relational thinking. *Zentralblatt fur Didaktik der Mathematik*, 37, 87-115.
- Cobb, P. (1995). Cultural tools and mathematical learning: A case study. *Journal for Research in Mathematics Education*, 26(4), 362-385.
- Cobb, P. (2000). Conducting teaching experiments in collaboration with teachers. In A. Kelly & R. Lesh (Eds.), *Handbook of Research Design in Mathematics and Science Education* (pp. 307-333). Mahwah, NJ: Lawrence Erlbaum.
- Jacobs, V., Franke, M., Carpenter, T., Levi, L., & Battey, D. (2007). Professional development focused on children's algebraic reasoning in elementary school. *Journal for Research in Mathematics Education*, 38(3), 258-288.
- Kieran, C. (1981). Concepts associated with the equality symbol. *Educational Studies in Mathematics*, 12, 317-326.
- Knuth, E., Stephens, A., McNeil, N., & Alibabi, M. (2006). Does understanding the equal sign matter? Evidence from solving equations. *Journal for Research in Mathematics Education*, 37(4), 297-312.
- Ministry of Education. (2007). *The New Zealand Curriculum*. Wellington: Learning Media.
- National Council of Teachers of Mathematics. (2000). *Principles and Standards for School Mathematics*. Reston, VA: Author.
- Stephens, M. (2006). Describing and exploring the power of relational thinking. In P. Grootenboer, R. Zevenbergen, & M. Chinnappan (Eds.), *Identities, Cultures and Learning Spaces Proceedings of the 29th Annual Conference of the Mathematics Education Research Group of Australasia*, (Vol. 2, pp.479-486). Sydney: MERGA.
- Warren, E. (2007). Exploring an understanding of equals as quantitative sameness with 5 year old students. In J. Woo, H. Lew, K. Park, & D. Seo (Eds.), *Proceedings of the 31st Conference of the International Group for the Psychology of Mathematics Education* (Vol. 4, pp. 129-136). Seoul: PME.

# **DO THEY KNOW WHAT TO ASK AND WHY? TEACHERS SHIFTING STUDENT QUESTIONING FROM EXPLAINING TO JUSTIFYING AND GENERALISING REASONING**

Roberta Hunter

Massey University

*In this study descriptions are provided of the interactional strategies four teachers used which gradually scaffolded student use of more complex questions and prompts. I report on the way the students appropriated the teachers' models of questions and prompts and used them to engage in exploratory talk (Mercer, 2000) and develop rich explanatory justification and generalisations.*

## **INTRODUCTION**

There have been many calls for change in the teaching and learning of mathematics in national and international policy documents (e.g., Ministry of Education (MoE), 2007; NSW Department of Education and Training (NSWDET), 2003; National Council of Teachers of Mathematics, 2000). A central hallmark of the change is a vision of teachers and students mutually engaged in shared mathematical dialogue within classroom learning communities (Manouchehri & St John, 2006; Wenger, 1998). In New Zealand, the policy document argues the need for teachers to facilitate shared discourse in which challenge, support, and feedback are made available so that students engage “in reflective discourse with others... and build the language to take their learning further” (MoE, p. 34). Similarly, Australian and American documents promote need for teachers to foster learning environments premised on the use of discursive interaction and within which they facilitate student participation in substantive communication and argumentation. These ambitious goals for change are fraught with many problems and pitfalls (Huford-Ackles, Fuson, & Sherin, 2004; Nathan & Knuth, 2003). This is particularly so because more conventional forms of classroom discourse in which teacher talk has dominated are likely to be the most common form of talk both students and teachers have experienced in former mathematics classrooms (Lampert & Cobb, 2003). The research reported in this paper examines one section of a collaborative research project in which four teachers worked to establish classroom communities of mathematical inquiry. The focus of the paper is on the strategies used by the four teachers to explicitly scaffold student inquiry. The aim is to examine how the teachers gradually shifted the focus of student inquiry from the use of questions which examined mathematical explanations to those which elicited justification and generalisations.

Many studies (e.g., Cobb, Wood, & Yackel, 1993; Manouchehri and St John, 2006; Nathan & Kim, 2007; Wood, Williams, & McNeal, 2006) have affirmed the importance of teacher-to-student and student-to-student participation in discursive discourse, on student engagement in high levels of cognitive reasoning. The students'

active engagement in such discourse provides opportunities for them to understand reasoning from the perspective of others, identify opposing views, and review, reconstruct, reshape and deepen their own understandings as they build stronger arguments (Rojas-Drummond, and Zapata, 2004; Whitenack, and Yackel, 2002). However, engaging in discursive interactions is not something young students achieve easily without explicit adult mediation. Therefore teacher support and scaffolding are required if students are to engage in what Mercer (2000) terms exploratory talk—a form of talk which consists of critical but constructive discursive exchanges. Exploratory talk is used in inquiry learning communities to closely examine and co-construct mathematical reasoning through extended discourse.

Of importance in the discursive exchanges are not only the mathematical arguments but also the questions and prompts teachers (and sometimes students) use to elicit further explanatory information or justification of the reasoning. They are powerful mediational tools which potentially foster higher order cognitive reasoning (Nathan & Kim, 2007; Wood & McNeal, 2003). Wood and McNeal illustrated the important role these have on interaction patterns in their analysis of different classroom cultures. In a conventional classroom culture prompts were used to gain teacher expected information, whereas in a strategy-reporting culture questions drew additional information about strategy solutions. Important differences were revealed in inquiry and argument cultures including development of more complex student reasoning and increased levels of interaction. The argument culture also included challenge or disagreement from the teacher or students which resulted in discursive exchanges that prompted justification of the reasoning. Wood and her colleagues (2006) subsequently noted that it was through participating in discursive interactions that students were able to appropriate the knowledge and skills of when and how to engage in mathematical inquiry and argumentation.

I explained earlier that scaffolding student participation in substantive communication and argumentation is a complex process which requires explicit teacher attention. Exemplars of how inquiry and argument cultures might be achieved are required to support teachers as they develop the discourse. Currently there are studies which examine elicitation strategies used by teachers but there appear to be few studies available which describe how teachers might scaffold students to autonomously use questions and prompts which promote higher reasoning. In this paper descriptions are provided of the interactional strategies four teachers used which explicitly scaffolded students to use more complex questions and prompts. As the teachers reconstructed their expectations and obligations for student participation evidence is provided of how questions and prompts were appropriated and used by the students to examine and develop rich explanatory justification and generalisations.

The theoretical framework of this study is derived from a sociocultural perspective. Sociocultural theorists are united in their belief that collaboration and conversation are tools which mediate the transformation of external communication to internal thought (Mercer, 2000). In an environment in which mathematical teaching and

learning is inherently social and embedded in communicative discourse students successively gain greater levels of legitimate participation (Wenger, 1998) through the guided socialisation provided by teachers.

## **RESEARCH DESIGN**

The study reports on case studies of four teachers who participated in a collaborative one-year design research study. The study was conducted in a small urban New Zealand primary school where the students came from low socio-economic home environments. The students were predominantly of Pacifica and New Zealand Maori ethnic groupings.

A qualitative design research approach (The Design-Based Research Collective, 2003) was used to focus teacher and researcher attention on the social processes of mathematical discourse while also being mindful of the mathematical product. Attending to the key characteristics of design research; its interventionist nature, iterative cycles of analysis, and an improved product or process; a communication and participation framework was devised. The framework initially drew on the theoretical framework proposed by Wood and McNeal (2003). It was used by the teachers as a flexible and adaptive tool to map out and reflectively evaluate pathways of pedagogical actions, to use, to guide the development of collective reasoned discourse. An additional tool developed in a study group took the form of a framework of questions and prompts. Questions and prompts suggested by Wood and McNeal provided the foundations. Then it was further developed as the teachers examined classroom video recorded observations and identified specific questions and prompts which influenced student interactions and drew more complex reasoning.

Data collection over one year included three individual interviews, classroom artefacts, field notes, twice weekly video recorded observations of lessons, written and recorded teacher reflective statements and teacher recorded reflective analysis of video excerpts. On-going data collection and analysis maintained a focus on the developing discourse patterns. Data analysis occurred chronologically using a grounded approach in which codes, patterns and themes were created. Through use of a constant comparative method which involved interplay between the data and the theory, trustworthiness was verified or refuted.

## **RESULTS AND DISCUSSION**

Early in the study the discourse patterns evident in all teachers' classrooms were those most often associated with conventional classrooms in which teacher talk and questioning dominated. To shift towards developing substantive communication the teachers drew on the communication and participation framework and used it as a tool to map out their immediate and subsequent goals for scaffolding the discourse of inquiry. In turn, the on-going analysis of developing communication patterns drew attention to the emerging questions and prompts and how these mediated specific forms of reasoning. As the study progressed a close relationship became evident in



the level of complexity of the mathematical reasoning, the communication patterns and the questions and prompts. To illustrate this, exemplars of the dialogue from the different classrooms are provided.

### **Scaffolding questioning of mathematical explanations**

An immediate focus was placed on the students collaboratively developing mathematically clear, logical, and well reasoned conceptual explanations. They were provided with many opportunities to construct, explain, and, in turn, question and clarify the explanations step-by-step. The intent was to develop their skill in the construction, examination, and analysis of mathematical arguments. In the first instance questions which drew further information related to an explanation were explicitly modelled, student use of them monitored, and appropriate student use of them positively affirmed. Space and time intentionally provided during large group examination of mathematical explanations provided the students with many opportunities to question to clarify the reasoning.

Teacher: Ask questions so you can understand what is happening. Think about ones like what did you do with 'whatever', or can you show us what you did with this bit.

Tere: Where did you guys get the ten from?

Mereana: The ten, oh five times two.

Teacher: That's good. I can see now that you all can see what is happening, a good question Mereana to clarify.

Although it took each teacher variable lengths of time the steady shift each made towards developing collective construction and analysis of the arguments in the different learning cultures operated as a scaffold for the introduction of more complex forms of questions and prompts.

### **Scaffolding questions and prompts for justification**

Inducting the students into discourse premised on inquiry and justification presented more challenges. Initially the teachers voiced concern about the conflict between what they perceived their Maori and Pacifica students' current repertoire of cultural practices were and the need for them to engage in mathematical arguments. Also, they believed that if their students only experience of arguing had been of an aggressive form this would have shaped negative beliefs about mathematical arguing. Furthermore, they thought that asking the students to argue and disagree appeared to contradict their previous emphasis on developing collaborative talk. Therefore, structuring the concept of justification and arguing were enacted step-by-step beginning with scaffolding student use of mathematical agreement and disagreement.

In the first instance, at specific points in an explanation, the listening students would be asked to take a position- agree or disagree with a conjecture.

Teacher: At some point you are going to have an opinion about it. You are going to agree with it or you are going to disagree.

The term ‘maths arguing’ was introduced and direct explanations of ways the students could ‘maths argue politely’ was a feature of discussions in each classroom. In the consistent press gradually the students learnt that it was their responsibility to analyse an explanation and back their stance mathematically. Through the discourse they learnt that conjectures were always revisable and that responsibility to challenge reasoning shifted beyond consideration of social or power relationships.

Teacher: Do you agree? Remember don't just accept something and it doesn't matter how good everybody else is around you who is doing the maths, you have to listen to what they say but question it and clear it up in your mind or keep questioning and you might disagree. Your argument might change their mind too and that's good for all of us. What about you Hemi agree or disagree, have a think and then give us your reasons.

Harry: I agree because even though we did it different you know how they had seventy pumpkins they had two crates and so they just doubled and doubled again until they get up to 770.

Emphasis placed on need to take a mathematical stance provided a platform to shift the discourse from questioning and examining explanations toward questioning for explanatory justification. In the study group we analysed video excerpts and added both the teachers' and students' questions and prompts to the framework, extending it to encompass questions which challenged. Questions on the framework were used as models and before mathematical activity students were pressed to extend their repertoire.

Teacher: I want you people asking questions...throughout ask questions. Why did you come to that decision? Why did you use those numbers? If you say that, can you prove that, that really works? Can you convince me that this one works the best?

Two of the teachers also chose to develop wall chart models of questions and prompts and continuing to add others they heard the students using. A further press included the use of specifically designed problems which positioned the students to take a stance and required their close examination of the reasoning to justify their position. A shift in the complexity of questions and reasoned responses was evident as the students appropriated and used the more advanced questions and prompts modelled by their teachers. Student agency deepened as they listened closely within a shared perspective, actively tracked and analysed each step of a conjecture, and then often without need for a teacher prompt stepped in to question and probe further.

Recognising that explanatory justification often required more than one form of explanation the teachers required that the students consider developing multiple ways to validate their reasoning and convince others. They also asked the students to analyse, compare and justify similarities and differences in efficiency and sophistication between explanations. This press, coupled with the development of multiple forms of explanatory justification, and the need to question until convinced provided another platform-the mediation of generalised reasoning.

### Using the questions and prompts for justification to scaffold generalisations

All teachers initially exhibited difficulties attending to and developing generalised reasoning in their classrooms. It was the increase in the shared discourse of inquiry and argumentation, the spontaneous student voiced observations of underlying structures and properties of numerical patterns which provided them with tools to work with. As they became more attuned to hearing student generated numerical generalisations they began using them to explicitly develop and refine the thinking. However, an important shift occurred when members of the study group observed in a videoed observation a subtle move in one classroom when a student requested not only justification but also proof that a solution strategy would work with other numbers. This led to further exploration and extension of the framework to include questions and prompts to draw generalised reasoning. Again questions like how does that work and why were explicitly modelled and discussed and students were directed to explore the results of the questions.

Teacher: I want you to stop and think about this question, does what they just showed you always work, take some time and talk to the person sitting next to you about it; try it out on other numbers. Ask each other another good question, how can we know for sure; why does it always work?

The students appropriated the rich range of questions and prompts and these provided them with tools which mediated their interactions in the mathematical discourse. They readily adopted exploratory talk to critically examine reasoning and develop a collective view. Access to the different forms of questions and prompts enabled them to view the reasoning from a range of perspectives. Towards the conclusion of the study their explorations often extended to the use of generalised reasoning as a form of explanatory justification. This is illustrated as the students discuss a problem which requires that they multiply forty by twenty-four.

Akeriri: What about if we start by going ten times twenty-four equals two hundred and twenty-four then times two equals four hundred and eighty.

Immediately Saawan begins to use exploratory talk to clarify and his question extends the explanation.

Saawan: But where did you get the two, why are you timesing that by two?

Akeriri: I got it from forty. I halved forty that gave me twenty so that's the two.

Kuini listening leans forward and to validate her understanding of the explanation she probes further and adds a challenge.

Kuini: Hang on. So if you are saying you got the two from the twenty then do you mean that ten times twenty-four equals two hundred and twenty-four times another two equals four hundred and eighty is the same as twenty times twenty-four? But why start with two? You need to convince us.

Akeriri: Because two is easier than four timesing. It's sort of like what Saawan showed us yesterday. Yeah and then I go times two again and it's nine hundred and sixty because that is the same as four times ten times twenty-four or forty times twenty-four. Are you all convinced?

The students continue discussing the argument and connecting it with other explanations they have discussed. Pania then adds a new direction to explore.

Pania: Hey. Would that strategy work with other numbers? Hey what about this? You could do eighty times over twenty-four hours.

Kuini: I agree but those are all even numbers. So does it work with only even numbers because you can't half an odd number?

Akeriri: Saawan did it yesterday when he did nineteen but that wasn't the same strategy, that's changing it.

Pania: I disagree. It's just changing the numbers. I think you could take one lot off and then multiply it and then add the one lot back and it's the same. Or use Akeriri's way put the other one back it works so you can do odd.

In the extended close examination of the reasoning, access to multiple solutions and a range of tools and prompts, the students were able to autonomously provide explanatory justification using generalised reasoning.

## CONCLUSIONS

The design research study involving a communication and participation framework and a framework of questions and prompts was designed to induct the students into inquiry and argument learning contexts. The direct focus the teachers placed on modelling questions and prompts to scaffold sense-making of mathematical explanations provided the foundation for inducting students into the use of more complex questions. In turn, student appropriation of the questions and prompts supported the development of exploratory talk in which the students had tools to critically analyse and construct shared reasoning. Moreover, evidence is provided that the students' proficient use of questions and prompts extended mathematical reasoning to justifying and generalising.

Wood and her colleague (2006) identified the differential outcomes for students in different classroom learning cultures. These differences were evidenced in this study as the students increasingly gained access to knowledge of when and how to engage in the discourse. Nathan & Kim (2007) suggested that the questions and prompts used by teachers can foster higher order cognitive reasoning. The findings of this study suggest that student questions can also achieve this if teachers directly scaffold them to use questions and prompts of increasing complexity.

## References

- Cobb, P., Wood, T., & Yackel, E. (1993). Discourse, mathematical thinking, and classroom practice. In N. Minick, A. Stone, & E. Forman (Eds.), *Contexts for Learning* (pp. 91-119). New York: Oxford University Press.
- Huford-Ackles, K., Fuson, K. C., & Sherin, M. G. (2004). Describing levels and components of a math-talk learning community. *Journal for Research in Mathematics Education*, 35(2), 81-116.
- Lampert, M. & Cobb, P. (2003). Communication and language. In J. Kilpatrick, G. W. Martin, & D. Schifter (Eds.), *A Research Companion to Principles and Standards for*

- School Mathematics* (pp. 237-249). Reston, VA: National Council of Teachers of Mathematics.
- Manouchehri, A. & St John, D. (2006). From classroom discussions to group discourse. *Mathematics Teacher*, 99(8), 544-552.
- Mercer, N. (2000). *Words and Minds*. London: Routledge.
- Ministry of Education, (2007). *The New Zealand Curriculum*. Wellington: Learning Media.
- Nathan, M. J. & Kim, S. (2007). Regulation of teacher elicitations and the impact on student participation and cognition (WCER Working paper No. 2007-4). Madison: University of Wisconsin-Madison, Wisconsin Centre for Education Research. Retrieved 20 December, 2007 from <http://www.wcer.edu/publications/workingPapers/papers.php>
- National Council of Teachers of Mathematics. (2000). *Principles and Standards for School Mathematics*. Reston, VA: Author
- NSW Department of Education and Training. (2003). *Quality Teaching in NSW Public Schools*. Sydney, Australia: NSW Department of Education and Training.
- Rojas-Drummond, S. & Zapata, M. (2004). Exploratory talk, argumentation and reasoning in Mexican primary school children. *Language and Education*, 18(6), 539-557
- The Design-Based Research Collective. (2003). Design-based research: An emerging paradigm for educational inquiry. *Educational Researcher*, 31(1), 5-8.
- Wenger, E. (1998). *Communities of Practice: Learning, Meaning and Identity*. Cambridge: Cambridge University Press.
- Whitenack, J. & Yackel, E. (2002). Making mathematical arguments in primary grades: the importance of explaining and justifying ideas. (Principles and Standards). *Teaching Children Mathematics*, 8(9), 524-528.
- Wood, T. & McNeal, B. (2003). Complexity in teaching and children's mathematical thinking. In N. L. Pateman, B. J. Dougherty, & J. Zilliox (Eds.). *Proceedings of the 27<sup>th</sup> Annual Conference of the International Group for the Psychology of Mathematics Education*, (Vol. 4, pp. 435-443). Honolulu, HI: PME.
- Wood, T., Williams, G., & McNeal, B. (2006). Children's mathematical thinking in different classroom cultures. *Journal for Research in Mathematics Education*, 37(3), 222-255.

# TEXTUAL LITERACY IN MATHEMATICS- AN INSTRUCTIONAL MODEL

Bat-Sheva Ilany

Beit-Berl Academic College

Bruria Margolin

Levinsky College

*In the solution of mathematical word problems, problems that are accompanied by **text**, there is a need to bridge between mathematical language that requires an awareness of the mathematical components, and natural language that requires a literacy approach to the whole text. In this paper we have tried to show how it is possible to bridge gaps between natural language and mathematical language in solving mathematical word problems by means of an instructional model, whereby the addressee processes the text cognitively. The process of dealing with the verbal text of the mathematical problem is multi-staged, and necessitates the implementation of a number of cognitive actions: interpreting symbols and graphs, understanding the substance, understanding the linguistic situation, finding a mathematical model, and matching between the linguistic situation and the appropriate mathematical model. This instructional model was tested in a case study and was found very efficient.*

## INTRODUCTION

Mathematical language is a special type of language, different from natural language. It is a language of symbols, concepts, definitions, and theorems that needs to be learned and does not develop naturally like a child's natural language. In mathematical language the child learns to recognize, for example, numbers as objects, one to one of their similar and different properties. The child perceives the numbers as signs by means of which it is possible to calculate calculations and to do various manipulations.

In the solution of mathematical word problems, problems that are accompanied by text, there is a need to bridge between mathematical language that requires an awareness of the mathematical components, and natural language that requires a literacy approach to the whole text. A word problem in mathematics is an independent unit of text that comprises a question sentence and a speech event. This textual unit is coherent from a content and linguistic point of view. Sometimes the unit of text describes an event from daily life. The aim of the description is to give expression to the logical structure that dictates a particular arithmetic operation. The difficulty with the solution of mathematical word problems is the need to translate the event described in natural language to arithmetic operations expressed in mathematical language. The transition from natural language includes syntactic, semantic, and pragmatic understanding of the discourse.

Identification of the constituent parts of the text depends on meta-awareness of the function of the form, the function of the word, and the function of the sentence in a text, especially awareness of symbols and syntactic awareness (MacGregor & Price, 1999). The perception of the textual structure is a process by which you can identify textual components and carry out different logical operations.

There is a tendency in the professional literature to relate to a word problem as a textual unit that describes an everyday event, and the majority of papers and researches relate to problems not accompanied by an authentic background story as mathematical problems and not as word problems. Thus, this problem: "Find the equation of the straight line that is

parallel to the straight line  $3x - 7y = 4$  and passes through the point  $(0, 10)$ ” is not considered to be a word problem, rather a mathematical problem, since it is not accompanied by an authentic background story. An example for this could be Polya’s treatment in his book *How To Solve It* (1954) of mathematical problems accompanied by text as problems, although at the same time he suggested that for the problem to be understood it is first of all necessary for the verbal version to be understood. In our opinion, problems should also be defined as word problems since such problems include text that the solver needs to understand. **In this paper we will relate to every mathematical problem accompanied by text as a word problem in mathematics.**

A word problem needs bridging between natural language and mathematical language. Therefore it is necessary to educate towards mathematical-linguistic literacy<sup>1</sup>, at the level of the addressor (speaker or writer) and at the level of the addressee (listener or reader). From the point of view of the addressor, he must ensure that the references in the text are related to suitable referents, that the expressions are not ambiguous, and that all the problematic terms are made clear. In other words, the addressor must display consideration for the recipient by supplying easily accessible and acceptable information. As for the addressee, to extract the full meaning from the text he must fill in the missing information that is not found in the text.

The knowledge gaps in problem solving are between the textual unit and the hidden mathematical structure. The linguistic units in the text not only function as signs that have their signified object or idea in the world external to linguistics but also are connected to other fundamentals in the text, so that their meanings arise from the way the linguistic components are organized in the text. Moreover, not all the information is given explicitly in the text. There is information that can be derived by mathematical means on the basis of the explicit information.

Bridging between natural language and mathematical language necessitates connecting the two faces of the word problem: the linguistic situation on one side and the abstract structures on the other (Greer, 1997). According to the professional literature, the bridging can be carried out in two different ways: by translation of the linguistic situation into abstract structures (Polya cited in Reusser & Stebler, 1997), and by organization of the unit of mathematical content (Freudental, 1991). In this paper we suggest making an interaction between the two methods in a processive approach. We offer a model for the instruction and learning of the solution of mathematical word problems, which we developed, tested and validated during a period of four years (Ilany & Margolin, 2005).

### **A MODEL FOR THE INSTRUCTION AND LEARNING OF THE SOLUTION OF MATHEMATICAL WORD PROBLEMS**

Many researches that deal with varied subjects in the learning of mathematics—like, for example, *real mathematics* (de Lange, 1987), dilemmas in mathematics instruction based on different representations of concepts (Ball, 1993), solution of verbal questions (Nathan, Kintch, & Young, 1992), and learning concepts such as the concept of function (Kaput, 1993) -maintain that development of modeling skills is one of the important aims of a mathematics curriculum, and serves as a central pedagogical tool.

---

<sup>1</sup> There are many definitions of literacy. The abundance of definitions derives from the extension of the concept from the written language connection and from language altogether. Today literacy represents also orientation and competence in any area, and thus there are those who prefer to relate to it in the plural, and to differentiate between different literacies: linguistic literacy, computer literacy, mathematical literacy, and so on (Wohl and Shelo, 1998).

We propose in this paper a nine-stage instruction model for the solution of mathematical word problems (schemas appear in the diagram that follows):

### **Reading the Problem**

The first stage involves reading the problem *from the bottom up*, as a way of collecting the details. The process of reading is an accumulative process from the smallest units (the words) to the largest units (the whole text).

### **Understanding the Linguistic Situation**

The next stage involves reading the problem for a second time. The action of reading at this stage will be called in this paper the *warming up stage*: a multi-directional search as a way of *brainstorming*. At this stage the reader will ask himself the following questions: Are all the words clear? Are all the sentences clear? What are the keywords? Do I understand the keywords? What is the question? Do I understand the question? How can I describe the problem in my own words?

### **Understanding the Mathematical Situation**

A problem solver needs to identify the known facts and the logical-mathematical conditions of the problem-the connections and relationships between the mathematical data and the logical analysis of the problem. In other words, the connections between the classical elements-nouns connected to numerical quantifiers in different sentences of the text and time-space relationships between objects or events that appear in the text-and the semantic relationship between the classical elements that are the verbs that appear in different sentences of the text (Nesher & Katriel, 1977; HersHKovitz & Nesher, 1996). At this stage the reader will ask himself the following questions: Is there a difficulty in the problem? Are all the data clear? Are there implicit data in the problem? Do I understand the connection between the data in the question? Is it possible to demonstrate the problem in particular instances?

### **Matching the Mathematical Situation to the Linguistic Situation**

This stage involves reading the problem once more, from the top down. The action of reading at this stage is the application of schemas on the text, where the location of the meaning is in the reader's knowledge schemas. The process of reading at this stage is an accumulative process from the combining of mathematical knowledge schemas with the schemas in the text. At this stage the reader will ask himself the following questions: Do the nouns in the question appear again in a more general unit? Do the connectives that appear in the question relate to different mathematical sizes? Are there literal clues in the problem, that is certain words that help as a clue for choosing the arithmetic operation required for solving the problem? Is it possible to demonstrate the problem by means of a picture, a table, a diagram, or a graph?

### **Bringing up Ideas for a Solution**

In this stage it may be necessary to analyze the problem in different ways, to identify the problem before attempting its solution (Schoenfeld, 1980). To change the search to systematic, it is necessary to know problem-solving strategies. There exist general strategies, and strategies specific to different types of problems. Usually, students are given problems similar to those they solved in the past. Therefore, according to Polya (1954), there arises the question: Do you know a problem close to this one? At this stage the learner will ask the following questions: Is the problem unique? Have I encountered similar problems? Is it possible to construct a schema for solving the problem on the basis of past experience?



### **Screening the Ideas**

After raising different ideas for a solution of the problem, it is necessary to check each one of them, whether it truly helps to solve the problem. It is necessary to screen them, and to retain only relevant ideas. At this stage the learner will ask the following questions: Does the idea help to solve the question? How does the idea help to solve the question?

### **Building a Mathematical Model**

Researchers who are concerned with the process of building a mathematical model for a phenomenon agree that the meaning of the process is mathematization of a phenomenon (Yerushalmi, 1997) or, according to Ormell's (1991) version, a mathematical description of the whole phenomenon instead of checking isolated parameters in the phenomenon. Consequently, we define mathematical model building as constructing representations in mathematical language like an exercise or an equation.

At this stage the learner will ask the following questions: What will I do as a first stage to solving the problem? Do I know how to solve the problem and to build an appropriate mathematical model? What mathematical model should I use to solve the problem?

The learner will construct a schema that represents the network of connections between his previous knowledge and the schemas in the mathematical text by means of an interaction with the following operations: defining the problem and comprehending the situation it describes; building a mathematical model of the mathematical principles relevant to the problem; understanding the relationships and the conditions pertaining to the problem; and using of the mathematical model.

### **Finding the Solution**

After finding the mathematical model, it is necessary to solve it to reach the expected solution. It is important to check if this is a unique solution or if there is another possible solution; all possible solutions must be found. At this stage the learner will ask the following questions: Is the solution unique? What are all the possible solutions to the problem?

### **Control**

It is necessary to check that the solution to the problem is suitable to the problem itself. That is to say, it is necessary to return to the original problem, to read it again, and to check: Does the solution make sense? Is the solution appropriate to the linguistic situation? Is the solution appropriate to the mathematical situation? Does the mathematical model that I used fit the problem? This stage is the most important, because many times it seems as if we have found the solution, but the solution does not make sense, and so we need to redo the process from the beginning. It is worthwhile testing the solution, and checking all the steps that lead from the data to the solution.

It is important to note that in every word problem it is necessary to pass through all the stages. However different learners need to focus on different stages (since some of the stages are already *automatic*). During instruction it is necessary to go over a different stage each time, and to locate the stages with specific difficulties for different learners and to focus on them (examples will follow).

Mathematicians focus also on a further stage-the efficiency stage. They check whether the solution is efficient, whether it is possible to solve in a different manner, and whether there exists a shorter method of solution.

A sketch of the teaching and learning model appears in the following diagram:

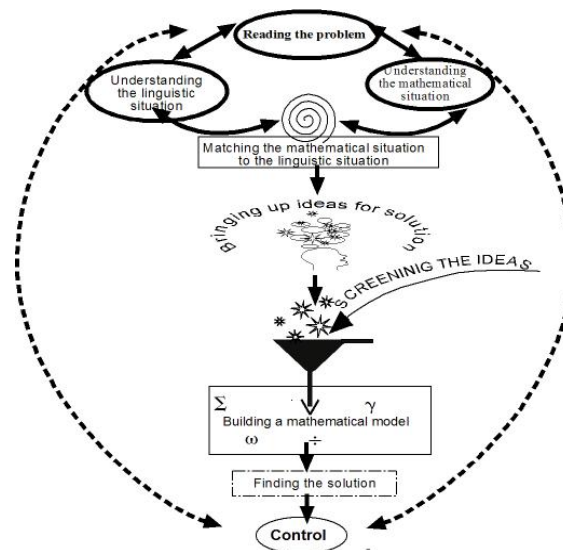

Figure 1. A sketch of the teaching and learning model for the solution of mathematic word problems.

### APPLICATION OF THE TEACHING AND LEARNING MODEL - A CASE STUDY OF SHIRI

As for example, we report here, the application of the model in the case of Shiri. Shiri is a good student in the ninth grade. She, however, had some difficulties in understanding and solving the following word problems that did not describe everyday events and were not accompanied by an authentic background story:

1. Find the equation of the straight line, parallel to the line  $3x - 7y = 4$ , passing through the point  $(0, 10)$ .
2. Find the equation of the straight line, with a slope of  $-5$ , that cuts the  $y$  axis on its negative side at a distance of three units from the origin.

Shiri did not know how to solve these problems, and claimed, “I do not understand what is written, so ...either I do something or I do not do anything. In the first problem I substituted in the line I had and got  $y = 3x + 10$  and that was not the correct answer (explanation: Shiri took the  $3x$  from the original equation and added 10 because the line passes through the point  $(0, 10)$ ). The other problems I did not understand at all, and so I did not solve them”.

To enable Shiri to solve these problems we used all the steps of the above model. We worked on each problem separately.

**Problem no. 1: Find the equation of the straight line, parallel to the line  $3x - 7y = 4$ , passing through the point  $(0, 10)$ .**

To enable Shiri to solve the problem we used all the steps of the above model.

- a. **Reading the problem** - At the first stage Shiri was asked to read the problem aloud.
- b. **Understanding the linguistic situation** - At this stage, once it was clear that Shiri understood all the words in the problem, we asked her to mark the keywords. Shiri marked them as follows: “equation of the straight line”, “parallel”, and “passing through the point”.
- c. **Understanding the mathematical situation** - Despite the fact that Shiri understood all the words linguistically and marked the keywords, she did not yet understand the

mathematical context. Shiri was asked to express what she thought the problem was about. She said, "To find a new line". Shiri was asked whether the given information was clear and whether she understood the connections between the pieces of information and the problem. Shiri did not understand the connection between the given information and the problem, despite the fact that the general conceptual frame of the problem was clear to her – she knew what a straight line and a parallel line are.

- d. **Matching the mathematical situation to the linguistic situation** - At this stage Shiri needed to process the verbal information to convert it into a mathematical exercise (equation). Shiri was asked a general question about straight lines, "What is the equation of a straight line?" Shiri answered and wrote down  $y = mx + n$ , but she claimed that in the question there was no equation of a straight line. Shiri was asked what she thought "parallel" meant, and she answered, "A line that has the same (slope)  $m$ ". At this stage integration took place between Shiri's schemas concerning the equation of a straight line and her schemas concerning the text. Shiri was asked to look at the equation written in the problem and to think how it might be possible to convert it into the equation of a straight line like the one she just wrote. Then Shiri said, "I need to convert the equation into the equation of a straight line. Oy! In the test I made a mistake. In the test I took the coefficient of  $x$ , the 3, and I related to it as if it were the slope and that is wrong. It is forbidden to relate to the coefficient of  $x$  as if it were the slope, like I did in the test".
- e. **Bringing up ideas for a solution** – Shiri suggested moving the  $3x$  to the right-hand side and wrote  $-7y = 4 - 3x$ . Shiri did not know what to do, and said, "This is still not the familiar equation of a straight line. I do not know what to do with the minus". Then Shiri was asked, "On the basis of your past experience, can you convert this equation to the equation of a straight line?" Shiri said, "In fact I can move the  $-7y$  to the other side' and then I would not have the problem of the minus".
- f. **Screening the ideas** - Shiri was asked, "Which idea would you chose to solve the problem?" Shiri showed the equation  $7y = 3x - 4$  and claimed that it reminds her of the equation  $y = mx + n$  because there is no minus before the  $y$ .
- g. **Building a mathematical model** - Shiri was asked, "What can you do now to bring the equation to the same form as the equation  $y = mx + n$ ?" Shiri looked again at the equation and said that in her opinion she needs to "get rid of" the 7.
- h. **Finding the solution – After Shiri's insight concerning the equation of a straight line and the meaning of a line parallel to the given line**, Shiri solved the problem correctly. Shiri was asked whether this was the only solution. She answered, "Since this is a line parallel to a given line and passing through a certain point there is only one solution."
- i. **Control** - Shiri was asked whether the solution made sense and met the conditions of the problem. She answered, "I think so." When asked how she could check it, she substituted the point  $(0, 10)$  into the equation of the line and said, "I got a true statement, and the line is parallel to the given line, so my solution is correct."

**Problem no. 2: Find the equation of the straight line, with a slope of  $-5$ , that cuts the  $y$  axis on its negative side at a distance of three units from the origin.**

In the test Shiri wrote  $-3 = -5x + n$ . She wrote  $-3$ , "Because it is 3 units from the origin and crosses on the negative side." Again, to enable Shiri to solve the problem we used all the steps of the above model.

- a. **Reading the problem** - At the first stage Shiri was asked to read the problem aloud.

- b. **Understanding the linguistic situation** - At this stage, once it was clear that Shiri understood all the words in the problem, we asked her to mark the keywords. Shiri marked them as follows: “with slope”, “cuts the y axis”, and “negative side”.
- c. **Understanding the mathematical situation** - Despite the fact that Shiri understood all the words linguistically and marked the keywords, she did not yet understand the mathematical situation. Shiri was asked to express what she thought the problem was about and it transpired that she did not understand the significance of “cuts the axis”. Shiri was asked to draw any line on the co-ordinate axis. By means of the drawing we worked with her on the meaning of “cuts the axis”. Once she understood the meaning, Shiri was asked to draw a line according to the requirements of the problem, and she drew correctly.
- d. **Matching the mathematical situation to the linguistic situation** – At this stage Shiri needed to process the verbal and graphical information to turn it into a mathematical exercise (equation). Shiri wrote  $y = mx + n$ , reread the problem, and wrote  $y = -5x + n$ .
- e. **Bringing up ideas for a solution** - Shiri said” I will substitute the point (-3, 0) or maybe the opposite, I will substitute (0, -3) in the equation.”
- f. **Screening the ideas** - Shiri thought, and analyzed aloud the meaning of the points. She returned to the graph and decided what to substitute.
- g. **Building a mathematical model** - Shiri substituted the point (0, -3) in the equation  $y = -5x + n$ .
- h. **Finding the solution** - Shiri continued and solved the problem correctly. Shiri was asked whether that was the only solution. She answered, “Since it is a line with a given slope that passes through the point (0, -3), there is only one solution.”
- i. **Control** - Shiri was asked whether the solution made sense and met the conditions of the problem. She answered, “I think so.” When asked how she could check it, she reread the problem and substituted the point (0, -3) into the equation of the line and said, “I got a true statement, and the line has a slope of -5, so my solution is correct.”

## CONCLUSION

To educate for linguistic-mathematical literacy, that is to enable the addressee to have the ability to decipher text in which there are mathematical components and to make reasonable deductions, attention must be paid not only to intuitive processes, but also to cognitive and meta-cognitive processes. These can be improved by means of practice and reorganization (e.g., Feurstein et.al., 1986; Sternberg, 1985), and by developing strategies for general thinking (e.g., Polya, 1954) including strategies that organize processes and skills that guarantee fluent performance. Development of thinking strategies will enable the “screening” of intuitive processes (Fischbein, 1987) in which the effort is focused on finding “automatic” solutions and will lead towards thinking of possible solutions of the problem. A tendency to think of “automatic” solutions often constitutes a trap. Immediate solutions reflect hidden assumptions that lead to misunderstanding the problem, and as a result to mistakes, excluding other better solutions (Perkins, 1986).

In this paper we have attempted to show how it is possible to bridge gaps between natural language and mathematical language in solving mathematical word problems by means of an instructional model, whereby the addressee processes the text cognitively. The process of dealing with the verbal text of the mathematical problem is multi-staged, and necessitates the implementation of a number of cognitive actions: interpreting symbols and graphs, understanding the substance, understanding the linguistic situation, finding a mathematical model, and matching between the linguistic situation and the appropriate mathematical model.

The instruction and learning model proposed here is a meta-cognitive process that contributes to students' conceptualization (Nastasi & Clements, 1990). Knowledge of meta-cognitive processes assists in problem solving and improves the ability to achieve goals.

We recommend teachers to “hitch” mathematical language to natural language: to avoid problems that have no connection with reality, to avoid ambiguous problems, to explain to the students the differences between natural and mathematical languages and the possibility of combining them.

We recommend teachers to make intelligent use of the instruction and learning model presented above, that is, to adapt the model and its various stages both to different populations of students and to the nature of the problems and their complexity.

The instruction and learning model suggested here is suitable for students in the upper grades of elementary school, in middle and high schools, and in teacher training colleges. In elementary school, the majority of problems available to students have a numerical solution with real –life meaning, and so it is important to understand the situation described in them. In their continued studies in middle and high school students will have to cope with problems that do not necessarily have a numerical solution, and will have to use algebra to solve them.

Graduated work on solution methods of word problems using schemas built in previous work on simply word –problem solving will enable students to cope with more complex problems. Moreover, adapting the model for different students will enable teachers to help every student according to his needs and to pinpoint the focus of difficulty for each student.

Intelligent use of the suggested model of instruction and learning will also help student teachers, both in their training and in their teaching practice. Understanding the model will allow the starting teacher to understand that meta-linguistic awareness, syntactic and semantic awareness, and awareness of mathematical schemas are necessary for solving problems in mathematics. Furthermore, the way the problem is worded and its correspondence to reality can significantly affect students' ability to solve the problem.

### Selected Bibliography

- Ball, D. L. (1993). With an eye on the mathematical horizon: Dilemmas of teaching elementary school mathematics. *Elementary School Journal*, 93, 373-397.
- De Lange, J. (1987). *Mathematics Isight and Meaning*. Utrecht, Holland: Rijksuniversiteit.
- Fischbein, E. (1987). *Intuition in Science and Mathematics: An Educational Approach*. Dordrecht, Holland: Reidel Pub.
- Fennema E. & Carpenter T.R. (Eds.) *Integrating Research on Graphical Representation of Functions*. London: Lawrence Earlbaum Associates
- Freudenthal,H.(1991).*Revising Mathematics Education*. Dordrecht: Kluwer.
- Greer, B. (1997). Modeling reality in the mathematics classroom: The case of word problems. *Learning and Instruction*, 7, 293-307.
- Hershkovitz, S. & Nesher, P. (1996). The role of schemes in designing computerized environments. *Educational Studies in Mathematics*, 30, 339-366.
- Ilany B., Margolin B.(2005). *A procedural Model for the Solution of Word Problems in Mathematics*. . The 29th Annual Meeting of the International Group for the Psychology of Mathematics Education, University of Melborn, Melborn, Austrlia.
- Kaput J. J. (1993). The urgent need for proleptic research in representation of quantitative relationships. In Romberg T.A., MacGregor, M. & Price, E. (1999). An exploration of aspects of language proficiency and algebra learning. *Journal for Research in Mathematics Education*, 30(4), 449-467.
- Nastasi, B. K. & Clements, D. H. (1990). Metacomponential functioning in young children. *Intelligence*, 14, 109-125.
- Nathan, M.J., Kintsch, W., & Young E., (1992). A theory of algebra-word-problem comprehension and its implications for the design of learning environments. *Cognition and Instruction*, 9 (4), 329-389.
- Nesher, P. & Katriel, T. (1977). A semantic analysis of addition and subtraction word problem in arithmetic. *Educational Studies in Mathematics*, 8, 251-269.
- Perkins, D. (1986). Thinking Frames. *Educational Leadership*,43(8) 4-10.
- Reusser, K. & Stebler, R. (1997). Every word problem has a solution - the social rationality of mathematical modeling in school. *Learning and Instruction*, 7, 309-327.
- Yerushalmy, M. (1997). Mathematizing qualitative verbal descriptions of situations: A language to support modeling. *Cognition and Instruction*. 15, 207-264.

# REASONING FROM FEATURES OR EXEMPLARS

Matthew Inglis

University of Nottingham

Adrian Simpson

Durham University

*It has been argued that one of the fundamental reasons for the status of mathematics in the wider curriculum is its capacity for enhancing abstract reasoning skills. In this paper we explore the THOG task - a well known hypothetico-deductive reasoning problem. We identify the ways in which successfully solving it involves different aspects of cognition and we conduct an experiment using the THOG task with mathematics students as well as a general, well-educated population. The results show the mathematics students are a homogenous group which significantly outperforms general groups on the task and we consider an account for this performance in terms of mathematicians' tendency to deal with the defining features as opposed to making comparisons to exemplars.*

## MATHEMATICAL THINKING

Mathematics tends to have a privileged position within the wider curriculum. While one can argue that different philosophical positions lead to quite varied views of mathematics (along with its teaching and learning), the inclusion of some form of mathematics within any curriculum remains virtually unchallenged. Recent reports in the UK on the role of mathematics for those beyond the age of 14 have focussed on its apparently unique ability to develop students' analytic skills and their logical and abstract reasoning (QAA, 2002; Smith, 2004). The ability to deduce from formal definitions and the ability to construct and interpret chains of reasoning according to a normative logic are all aspects we might associate with advanced mathematical thinking (Rasmussen, Zandieh, King, & Teppo, 2005; Tall, 1992). Alcock and Simpson (2002) suggested, in particular, that the 'rigour prefix' - the crucial shift from dealing with categories by comparing to prototypes to dealing with them on the basis of formal definitions - is characteristic of the transition to advanced mathematics.

There is some evidence, however, that - taken at its most straightforward - the development of logical reasoning is far from a simple outcome of even the most advanced mathematical education. Inglis and Simpson (in press) demonstrated that even highly qualified mathematicians are susceptible to 'heuristic biases' (rules of thumb for decision making which don't always match the outcomes of logically correct reasoning), and Alcock & Weber (2005) suggested that few highly qualified mathematics undergraduates can evaluate and assess a flawed mathematical argument correctly.

In analysing the extent to which mathematicians do or do not reason as the general population does, we can look to some of the classic reasoning tasks developed by psychologists. While one can argue that these tasks are stripped even of the kind of context in which a mathematician might encounter them and thus cannot provide complete insight into mathematical reasoning as it is practiced, identifying

differences in responses between groups is highly suggestive of the fundamentally different ways in which these groups might reason.

In this paper we look at successful mathematics students' performance on a classification task which involves testing items against an apparently simple definition.

### **OUTLINE OF THE THOG TASK**

Wason (1977) developed the THOG task as a complement to his previously analysed 'selection task', one of the most analysed problems in the history of cognitive psychology. Both tasks were part of an attempt by Wason (and, subsequently, many others) to make sense of formal reasoning and, despite Piaget's suggestion of the accurate ease with which adults should perform formal reasoning, uncover potential explanations for the apparent poor performance on tasks which have very simple formal logical structure.

The form of the THOG task is a request to identify shapes which conform to a definition with an exclusive disjunction based on an unknown pair of features. A typical version of the task is shown in Figure 1.

In front of you are four designs: a black diamond, a white diamond, a black circle and a white circle:

You are to assume that I have written down one of the colours (black or white) and one of the shapes (diamond or circle). Now read the following rule carefully:

If, and only if, any of the designs includes either the colour I have written down, or the shape I have written down, but not both, then it is called a THOG.

I will tell you that the black diamond is a THOG.

Your task is to classify each of the designs into one of the following categories: (a) definitely is a THOG; (b) insufficient information to decide; (c) definitely is not a THOG.

Figure 1. The THOG Task.

Since the black diamond is a THOG, only two shape/colour pairings are possible in the definition: that the colour is black and the shape a circle, or that the colour is white and the shape a diamond. In either case, the white circle is a THOG and the other two shapes are not. Thus, no matter what the (unknown) choice of shape and colour as the basis for the rule, the classification of shapes as THOGs or non-THOGs is entirely determined.

Koenig & Griggs (2004a) found that, across a range of experiments with general well-educated groups, the mean percentage of those getting the correct response on

this standard, abstract form of the THOG task was just over 12%. There appear to be two main common errors, both based on stating that the white circle is definitely not a THOG and (Type A) that the other two definitely are THOGs or (Type B) that one cannot determine the classification of the other two (Griggs & Newstead, 1983).

Newstead, Girotto and Legrenzi (1995) analysed the cognitive processes involved in correctly solving the THOG task into four steps:

1. *Understanding the problem.* It is argued, in particular, that the exclusive disjunction within the definition (“Either ... OR ... but not both”) could be a source of particular difficulty, and Neisser & Weene (1962) suggested that such rules are harder to learn than conjunctions or inclusive disjunctions. However, Wason and Brooks (1979) showed that, when they chose their own shape/colour pairing, participants had no problems with using the disjunctive rule correctly to classify shapes, even though they could not solve the standard THOG problem
2. *Hypothesis Formation.* To solve the THOG task, one needs to identify that, because the black diamond is a THOG, the possible pairings for the rule are (black, circle) and (white, diamond). Again, however, Wason and Brooks showed that the vast majority of their participants could identify both of these as the only possible pairings
3. *Hypothesis Testing.* Having formed the possible pairings, the participants then have to test the remaining shapes against the rule with each of these pairings. Wason and Brooks showed that almost all participants could do this successfully when they chose a pairing for the rule, which suggests that checking whether the shapes fit the rule and a *known* pairing is unproblematic
4. *Combinatorial Analysis.* The THOG task involves two potential pairings, however and there is a significant combinatorial task involved in checking each of the three shapes against each of the two pairings for matching on one, and only one, feature of the pairing and noting that the outcomes are independent of the choice of pairing

It is in this last area which Newstead et. al. (1995) argued that the core of the difficulties with the THOG problem lies. They argue that, because of the complexity of co-ordinating the checking of features of possible pairings with the given shapes, participants fail to distinguish between the (unknown) pairing and the (known) pair of features of the given exemplar (black, diamond). In doing so, they may be taking the exemplar to be prototypical of a THOG and thus look for items which are similar to it. This would appear to account for the most common responses (ruling out the shapes which share no features with the exemplar and accepting or being unsure about those which share one feature).

One can argue that advanced mathematics should involve students in, at least, an increased wariness about prototypical thinking when one has recourse to formal definitions. Similarly, one can note that the four cognitive tasks Newstead et. al. (1995) identified as central to the successful completion of the task are common requirements of formal mathematical work. Thus one should look to whether mathematics students



perform substantially differently from the general population on this task. Indeed, when discussing the lack of research on how talented mathematicians perform on the THOG task, Newstead et. al. noted that “given [the] potential importance [of this question], it is high time this omission was rectified”.

The primary purpose of the study reported in this paper was to determine if there was a significant difference between the responses to the THOG task between a well qualified mathematical population and a general, well-educated population. Specifically we examined the pattern of responses, categorised according to the standard forms in the literature outlined above.

## **METHOD**

In order to maximise the number of participants, an internet based instrument was developed. The population consisted of 125 participants from three groups: mathematics undergraduates, early childhood studies undergraduates and primary school trainee teachers; all from one high-ranking UK university. The sample from the latter two groups had very similar results which closely mirrored those common in the literature and thus were conflated into a comparison group representing a ‘general, well-educated population’ (in keeping with the practice of the experiments detailed above).

E-mails were sent to every member of the three groups, asking them to participate and giving them access to a website with the THOG task. After an initial screen asking for some basic information, participants saw the problem in the form shown in Figure 1 with drop-down boxes to allow them to select whether they thought each shape was a THOG, was not a THOG, or whether there was insufficient information to tell. In addition, the time of completion and IP address of the participant was recorded. In doing so, we were following Reips (2000) advice about such internet studies to prevent the problem of multiple submissions (of which there was no evidence in this experiment). While there are other potential problems to collecting data through an internet form (most notably lacking control over the environment in which the data is entered), Krantz and Dalal (2000) suggested a remarkable degree of agreement between internet approaches and traditional lab-based approaches, and that the benefits of this approach outweigh these disadvantages.

## **RESULTS**

The basic results of the experiment are shown in Table 1. Recall that the correct answer is that, in addition to the given black diamond, the white circle is a THOG and the other two shapes (black circle and white diamond) are not THOGs. The two classic ‘intuitive’ errors both deny the white circle as a THOG and either (type A) state the other two shapes are definitely THOGs or (type B) state that one cannot tell about these other two shapes.

The basic results show that the comparison group (representing a general, well-educated population) had a similar pattern to that expected from the literature (e.g. Griggs & Newstead, 1983). However, there was a significant difference between the mathematics

undergraduates' and the comparison group's range of responses (Fisher-Freeman-Halton Exact Test,  $p < 0.001$ ) with a medium effect size,  $\Phi=0.445$ . As discussed below, this is similar to the size of the facilitation effect found by Koenig and Griggs (2004b).

	Maths		Comparison	
Correct	21	33%	2	3%
Type A	0	0%	8	13%
Type B	25	39%	26	43%
Other	18	28%	25	41%
<i>N</i>	64		61	

Table 1. The distribution of responses from each group

Table 2 gives the numbers classifying each test shape as a THOG, not a THOG or claiming 'insufficient information'. It should be noted that only four people (from 125) classified the white diamond and black circle into different categories and that on each test shape, the mathematics students significantly outperformed the control group: white diamond  $\chi^2(1)=16.8$ ,  $p < 0.001$ ; black circle  $\chi^2(1)=13.7$ ,  $p < 0.001$ ; white circle  $\chi^2(1)=14.3$ ,  $p < 0.001$ .

It appears, therefore, that the mathematics students were both more likely to confirm the white circle as a THOG (where the general population tended to determine it as not a THOG) and, despite a similar level of uncertainty, were more likely to determine the other shapes as not THOGs.

	Maths			Comparison		
	Y	N	C	Y	N	C
White diamond	1	27	36	16	6	39
Black circle	2	26	36	14	7	40
White circle	28	27	9	8	42	11

Table 2. Numbers classifying each shape as a THOG or not (or '(C)an't tell')

## DISCUSSION

Despite some unpublished evidence of greater performance by students with different backgrounds, the work of Newstead et. al. (1995) suggests that this result gives the first published evidence of a homogenous group who outperform the general population on this task. Recall that Newstead et. al. argued that the inability to coordinate the combinatorial analysis of the pairings with the test cases lies at the core of the problem. The complexity of this leads participants to work with the (known) exemplar (the black diamond) rather than the unknown feature pairs. Indeed, Wason (the originator of the problem) said

The basic conceptual difficulty with the THOG problem is that the person trying to solve it has to detach the notion of possible pairs of features away from the actual designs which exhibit those features (Wason, 1978, p50).

One could argue, therefore, that there are two basic approaches to solving the THOG task. One arises when, overwhelmed with the complexity of co-ordinating the combinatorial analysis, participants work by treating the given exemplar (black diamond) as a prototype to which they compare the test cases. Mynatt, Doherty, & Dragan (1993) suggested that people are generally only able to consider one hypothesis at a time. The co-ordination needed to work through two different hypotheses and note that the outcomes are identical in both cases may be too large a load for working memory. This overload may lead many to abandon attempts to work with the features alone and classify those shapes with a similar feature to the given exemplar (the black circle and white diamond) as more likely to be THOGs than that with no similar features (the white circle). These are indeed the classic errors seen in the literature and in our comparison group. In terms of a classical theory in the mathematics education literature, one might argue that these participants are utilising a concept image to determine THOGs (Tall & Vinner, 1981).

A second approach is, as Wason suggests, detaching the features from the exemplars and thus determining THOGs on the basis of whether the cases conform to the features of the definition rather than similarity to the given example. This approach might be classified, in terms of Tall & Vinner's (1981) framework, as a concept definition approach.

Of course, the earlier analysis shows that merely realising the need to work from the definition is not sufficient to successfully solve the problem. In particular, one needs to realise that the two possible definitions (which arise from the two possible pairings of shape and colour) give identical classifications and it may be this extra level of complexity which accounts for the relative lack of success even of those with considerable experience of working from definitions: two thirds of the mathematics students still selected an incorrect answer.

Further support for this account is provided by Koenig & Griggs (2004b) who found that success with the THOG task was facilitated by a subtle but important modification to the question in which specific features of the structure of the THOG problem were made more obvious. In particular, the modified task explicitly led participants to both generate both possible pairings for the rule and separate the exemplar from those possible pairings. When given this explicit support to focus on a definitional, rather than image-based approach, the participants had considerably more success and, indeed, the results from Koenig and Griggs showed a facilitation effect of very similar size to that in our experiment.

Koenig & Griggs (2004b) found that the general population can work from definitions, but only when given sufficient support to both make the definition explicit and to highlight its use rather than the use of an exemplar. Our results suggest, however, that mathematicians can do this to a similar extent without such support.

Thus we could characterise one of the main differences between the mathematicians and the general population which may account for their relative success as precisely one of the aspects of reasoning we hope that a good mathematical education may engender: the development of a ‘rigour prefix’ and the ability, in combinatorially quite complex cases, to focus classification on defining *features* rather than on similarity to *exemplars*.

## References

- Alcock, L. & Simpson, A. (2001), The Warwick Analysis project: practice and theory. In D. Holton (Ed.), *The Teaching and Learning of Mathematics at University Level* (pp. 99-111). Dordrecht: Kluwer.
- Alcock, L. & Weber, K. (2005). Proof validation in real analysis: Inferring and evaluating warrants. *Journal of Mathematical Behavior*, 24, 125-134.
- Griggs, R. A. & Newstead, S. E. (1983). The source of intuitive errors in Wason’s THOG problem. *British Journal of Psychology*, 74, 451-459.
- Inglis, M. & Simpson, A. (in press). Conditional inference and advanced mathematical study. To appear in *Educational Studies in Mathematics*.
- Koenig, C. S. & Griggs, R. A. (2004a). Analogical transfer in the THOG task. *Quarterly Journal of Experimental Psychology*, 57A, 557-570.
- Koenig, C. S. & Griggs, R. A. (2004b). Facilitation and analogical transfer in the THOG task. *Thinking and Reasoning*, 10, 355-370.
- Krantz, J. H. & Dalal, R. (2000). Validity of web-based psychological research. In M. H. Birnbaum (Ed.) *Psychological Experiments on the Internet* (pp. 35-60), San Diego: Academic Press.
- Mynatt, C. R., Doherty, M. E., & Dragan, W. (1993). Information relevance, working memory and the consideration of alternative. *Quarterly Journal of Experimental Psychology*, 46A, 759-778.
- Neisser, U. & Weene, P. (1962). Hierarchies in concept attainment. *Journal of Experimental Psychology*, 64, 640-645
- Newstead, S. E., Girotto, V., & Legrenzi, P. (1995). The THOG problem and its implications for human reasoning. In S. E. Newstead & J. St. B. T. Evans (Eds.), *Perspectives on Thinking and Reasoning* (pp. 261-285). Hove, UK: Lawrence Erlbaum Associates Ltd.
- QAA (2002). Mathematics, statistics and operational research subject benchmark standards. Online article [accessed 05/01/2008]: <http://www.qaa.ac.uk/academicinfrastructure/benchmark/honours/mathematics.pdf>.
- Rasmussen, C., Zandieh, M., King, K., & Teppo, A. (2005). Advancing mathematical activity: A view of advanced mathematical thinking. *Mathematical Thinking and Learning*, 7, 51-73.
- Reips, U.-D. (2000). The web experiment method: Advantages, disadvantages and Solutions. In M.H. Birnbaum (Ed.) *Psychological Experiments on the Internet* (pp. 89-117), San Diego: Academic Press.

- Smith, A. (2004). *Making Mathematics Count: The Report of Professor Adrian Smith's Inquiry into Post-14 Mathematics Education*. London: The Stationery Office.
- Tall, D. (1992). The transition to advanced mathematical thinking: Functions, limits, infinity and proof. In D. A. Grouws (Ed.), *Handbook of Research on Mathematics teaching and learning* (pp. 495-511). New York: Macmillan.
- Tall, D. & Vinner, S. (1981). Concept image and concept definition in mathematics with particular reference to limits and continuity. *Educational Studies in Mathematics*, 12, 151-169.
- Wason, P. C. (1977). Self-contradictions. In P. N. Johnson-Laird & P. C. Wason (Eds.), *Thinking: Readings in Cognitive Science*. Cambridge: Cambridge University Press.
- Wason, P. C. (1978). *Hypothesis Testing and Reasoning*. Milton Keynes: Open University.
- Wason, P. C. & Brooks, P. G. (1979). THOG: The anatomy of a problem. *Psychological Research*, 41, 79-90.

# REFLECTIVE DISCOURSE AND THE EFFECTIVE TEACHING OF NUMERACY

Sonia Jones and Howard Tanner  
Swansea Metropolitan University

*An action research group of eight teachers investigated the impact of interactive teaching approaches based on mathematical argumentation and reflective discourse on pupils' numeracy. In a quasi-experiment, using control and intervention classes, the performance of 450 pupils, aged 11 to 13, were compared using pre, post and delayed tests of their written and mental mathematics. Overall, the intervention classes performed significantly better than their controls on the written, but not the mental tests. However, teachers varied considerably in their interpretation of the approaches and the extent to which they were able to use pupils' current thinking to develop mathematical understanding.*

## INTRODUCTION

At the turn of the century, the zeitgeist in Britain and much of the western world was concerned with standards of numeracy in schools. Definitions of numeracy varied widely between a narrow emphasis on basic arithmetical computation and quick recall of number facts to the ability to use a broad range of sophisticated mathematical proficiencies to solve problems. Most definitions referred to the ability and inclination to use mathematics to solve problems and an “at homeness” with number (Mathematical Association, 1992).

A broad view of numeracy is taken in this paper. To be numerate is not merely to have a secure knowledge of numerical facts and processes; numeracy requires the capability and disposition to construct personal approaches to the solution of problems, which are based on self-knowledge of individual strengths and weaknesses. To be numerate is to be able to mathematise situations, using techniques and processes which are confidently known, to generate a secure answer. Our definition of numeracy, therefore, involves an interaction between mathematical facts, mathematical processes, metacognitive self-knowledge, and affective aspects of mind including self-confidence and a disposition to construct personal methods.

In England, National Strategies (DfEE, 1999; 2001) offered highly prescriptive ‘guidance’ about pedagogy and demanded direct whole class teaching that was to be oral, interactive and lively. This was intended to be more dialogical than the traditional recitation script of Initiation, Response, Feedback (IRF) (Sinclair & Coulter, 1975).

Teachers in Wales, where this study was set, were not obliged to follow the English Strategies, but were encouraged to use their professional judgement to interpret guidance from a range of sources. This paper focuses on a group of Welsh teachers

who chose to investigate the impact of interactive teaching approaches, based on mathematical argumentation and reflective discourse, on pupils' numeracy.

### **INTERPRETATIONS OF INTERACTIVE WHOLE CLASS TEACHING**

Traditional classroom discourse is dominated by teacher talk. Pupils' contributions are typically restricted both in length and quality and the communication system is largely one way rather than bi-directional (Galton et al 1999).

Although the Strategies may have intended to encourage a more dialogical discourse, several studies have reported the resilience of the traditional discourse, the brevity of student responses and the lack of sustained interaction with individuals. Interactive whole class teaching has largely been implemented as pupil participation in fast, teacher-led question and answer sessions (Moyses et al., 2003; Hargreaves et al., 2003). Although teachers now ask more questions, most pupil responses remain very short, just five seconds on average, and involve three or fewer words. There is little opportunity for pupils to engage in extended responses or to express and evaluate ideas of their own (Hargreaves et al., 2003; Smith et al., 2004; Mroz et al, 2000).

Although these criticisms are of practice in England, Alexander's (2005) work on international comparative pedagogy suggests that most teaching is based on a basic repertoire of classroom talk consisting of rote, recitation and instruction / exposition. Although this basic repertoire allows teachers to maintain control over the content and direction of the discourse, it is unlikely to offer the level of cognitive challenge or scaffolding to confront misconceptions and extend children's thinking (Alexander, 2005). In particular it is unlikely to develop the metacognitive knowledge, self efficacy, or disposition to construct personal mental methods required for numeracy.

Opening up the discourse to include more dialogical or discussion based approaches offers the potential for greater pupil autonomy and deeper interactions, in which misconceptions may be exposed and confronted, and thinking scaffolded and extended. However, it demands greater levels of teacher skill (Alexander, 2005).

Scaffolding is an ill-defined metaphor for the support offered while learners are constructing new knowledge. In its traditional rigid form, it is based on simple, low level, funnelling questions in which the teacher does the thinking, makes the strategic decisions and leads the discourse to a predetermined solution (Bauersfeld, 1988). In its more dialogical form, scaffolding is more flexible and builds on pupils' own ideas.

Tanner & Jones (2000) report how teachers who used flexible, dynamic scaffolding were more successful than those who used the more rigid form. However, they also report that the teachers who were the most successful not only used a dynamic form of scaffolding but also generated a reflective discourse in their classrooms.

The effective scaffolding of discussion, especially in a whole-class situation is a highly complex task. There is a tension between advancing the dialogue and ensuring sense-making by individual pupils, between adherence to the lesson agenda and responsiveness to pupils' ideas (Sherin, 2002). Articulation of pupils' ideas through

discussion and argumentation provides an opportunity for them to test their understandings for viability against corporate meaning; it also contributes to the generation of corporate meaning. During class discussions, the social norms and patterns of interaction may be orchestrated by the teacher to create opportunities for pupils to reason for themselves and to engage in reflective thinking. During episodes of collective reflection, opportunities arise for pupils to reflect on and objectify their previous actions as they engage in reflective discourse (Cobb et al, 1997).

Dialogical pedagogies based on reflective discourse aim for classroom interactions that involve more than superficial participation. Teachers relinquish some measure of control of the trajectory of the lesson as pupils are offered a degree of collaborative control over the co-construction of knowledge. Tanner et al, (2005) offer a loose hierarchy of interaction in whole class teaching episodes in terms of the control of the trajectory of the lesson (see Table 1).

13	Nature of Interaction	Control of trajectory
Lecture	<i>No interactivity only intra-activity</i>	Low pupil control
Low level funnelling	<i>Rigid scaffolding/surface interactivity</i>	↑
Probing questions	<i>Loose scaffolding deeper interactivity</i>	
Focusing dialogue	<i>Dynamic scaffolding deep interactivity</i>	↓
Collective reflection	<i>Reflective scaffolding / discourse</i>	High pupil control

Table 1. Interactivity in whole class teaching (based on Tanner et al, 2005)

For classroom discussion to lead to mathematical learning, four key requirements must be met. Firstly, there must be a problematic - an unresolved or not trivially resolvable problem to sustain discussion. Second, the discussion must include opportunities for pupils to contribute ideas and listen to those of others. Third, there must be criteria for evaluation of the mathematical argument which must be supported by the introduction of 'more advanced' mathematical ideas. Finally, pupils must reflect on what they have learnt from the discussion (Ryan & Williams 2007).

There is evidence to suggest that a move towards dialogical pedagogies involving deeper forms of interaction, reflective discourse and collective reflection would lead to improved learning and attainment (Cobb et al, 1997; Tanner & Jones, 2000; Mercer & Sams, 2006). However, this would require a significant change to the dominant pedagogical practices in mathematics classrooms in England and Wales.

## RESEARCH DESIGN

The research utilised action research and a quasi-experimental design. Eight teachers from four schools in Wales volunteered to form an action research group to investigate the impact of introducing interactive teaching approaches based on mathematical argumentation and reflective discourse on pupils' numeracy. An action



research paradigm was appropriate because the teaching approaches required active interpretation and development by teachers rather than the presentation of a pre-specified course to pupils.

The intended teaching approaches were grounded in a socio-constructivist epistemology as mathematics was considered to be actively constructed by pupils rather than transmitted by the teacher. However, individual constructions occur in a social context and it was expected that pupils' thinking would also develop through acculturation into the negotiated mathematical culture of their classroom.

Written and mental test papers were designed to assess pupils' numeracy. Items emphasised comprehension rather than recall. The tests were reliable with Cronbach's alpha of 0.86 and 0.82 respectively (see Jones, 2008 for details). Matched pairs of classes in each school acted as control and intervention groups.

Pre-testing occurred at the start of the project in February, post testing after the end of the project in July and delayed testing in November of the following school year. The intervention lasted for five months during which teachers and researchers met monthly to develop, trial and evaluate teaching approaches. Additional qualitative data on teachers' interpretations and implementations of the approaches were gathered through participant observation of lessons, teacher diaries and interviews.

## RESULTS

Multivariate analysis of variance (MANOVA) was used to analyse the test data. Pre-test scores were used as covariates to add power to the analysis by adjusting for the small inequalities which existed between groups at the start of the quasi-experiment.

There was a statistically significant difference between the control and intervention classes on the written tests:  $F(2, 342)=4.85$ ,  $p=.008$ ; Hotelling's  $s=.028$ ; partial eta squared  $=.03$ .

	Dependent variable	Sum of squares	df	Mean square	F	Sig	Effect size
Written test	Post test	94.01	1	94.01	6.25	.013	.02
	Delayed test	135.20	1	135.20	8.67	.003	.03

Table 2. Univariate statistics for the effect of class (intervention or control)

The intervention classes significantly outperformed their control classes on the written tests. The improvement was significant beyond the 5% level on the post tests and beyond the 1% level on the delayed tests, although the size of effect was small in both cases (see Table 2). Teaching and learning approaches based on reflective discourse were successful in developing pupils' numeracy as assessed through written tests. This impact was achieved despite the short timescale of the teaching and was maintained through to the delayed tests which occurred three months after

the end of the project. The approaches resulted in a sustained improvement in the written tests of pupils' numeracy.

On the mental tests, the intervention classes did better than their controls on the post and delayed tests after controlling for initial differences. However, this improvement did not reach statistical significance. This lack of significant improvement was, perhaps, surprising given that the teachers were all committed volunteers keen to develop their own practice. However, the qualitative data indicated that teachers interpreted interaction in markedly different ways and this affected the degree of improvement in pupils' numeracy. One key variation between teachers was the extent to which they identified pupils' ideas and used these to modify the planned trajectory of the lesson and generate a reflective discourse. The two cameos which follow illustrate this qualitative characteristic distinction between the teachers.

### **Maureen's lesson on area**

The aim of the lesson was to find the length of the side of a square given its area, using trial and improvement. Squares of side 2, 3, 4 and 5cm were drawn and discussed in turn:

Maureen: So, the area of this square is  $25\text{cm}^2$  - so what would its side would be?

Pupil 1: It's  $5 \times 5$  so it's 5cm

Maureen: If I tell you the area is  $36\text{cm}^2$ , how would we find the side?

Pupil 1: Find the square root of 36, so it's 6cm.

The funnelling nature of the questioning together with the pattern arising from the ordered sequence of squares provided enough scaffolding for the pupils to follow Maureen's lead. However, the tenuous nature of the conceptual link between area and side for some of the pupils was revealed in the next sequence when Maureen moved on to squares with non-integer sides. She drew a square, wrote  $20\text{cm}^2$  inside it and asked pupils to guess its length. She chose pupils to answer:

Pupil 1: 10, Miss?

(Maureen gives no explicit feedback but selects another pupil to answer )

Pupil 2: 2?

(Maureen gives no explicit feedback but selects another pupil to answer )

Pupil 3: 4 point something?

Maureen: Why do you think it's 4 point something?

Pupil 3: Because  $4^2$  would give you 16 and  $5^2$  gives 25 so it'll be in between.

Maureen rephrased this response and focused the class's attention on why 4.5 would be a good starting number for trial and improvement. Pupil 3 came to the board to write up the solution, scaffolded by further funnelling questioning to the whole class.

Maureen chose not to discuss the incorrect answers but continued taking responses until a correct answer was obtained. The opportunity to use the misconceptions to create cognitive conflict and develop mathematical argument between the pupils was

not taken. In the post-lesson debrief, she indicated that she wanted to keep the focus on the procedure rather than risk a digression. She preferred to teach the correct procedure rather than modify or build on pupils' naïve constructs. Maureen's dominant mode of interaction was rigid scaffolding.

### **Fiona's lesson on fractions**

One challenge set by Fiona asked pupils to insert a fraction between  $2\frac{1}{3}$  and  $2\frac{1}{2}$ :

Fiona: Give me a number between  $2\frac{1}{3}$  and  $2\frac{1}{2}$ .

Pupil 1: Miss,  $2\frac{3}{8}$

Fiona: (In a non-evaluative tone) How do you know? Can you convince me that you are right?

(Pupil goes to board and draws circles divided roughly into halves, thirds and eighths. )

Fiona: (To the class) What do you think? Is he right? Are you convinced? (Some nods from class)

Pupil 2: But, ... the fraction parts need to be exactly the same size really ...

Fiona: Yes, they should be, shouldn't they. If you could draw them accurately then maybe that would be OK but with just rough sketches on the board I'm not convinced ... Can we find a more precise way to show it?

Pupil 3: Miss, we could change them to decimals ... (and the pupil is invited to the board to demonstrate the conversion)

Fiona: What do we think about that method? Is that OK? .... Yes? OK, any other ideas?

Pupil 4: Change them to a common denominator ... (and the pupil is invited to the board to demonstrate this and a similar evaluation follows.)

Fiona deliberately chose tasks which could create cognitive conflict and encourage argumentation. Characteristically, she used dynamic scaffolding and collective reflection to probe and build on pupils' ideas. In interview, Fiona indicated that she used dialogue to 'get inside their minds' to modify or develop any naïve constructs.

### **DISCUSSION**

Although analysis of the written tests indicates a significant advantage to classes taught using reflective discourse, the size of effect is small. Similarly, although the intervention classes outperformed their controls on the mental tests, the difference was not significant. We would suggest that the explanation lies in the variation in teachers' interpretations of interactive teaching.

Teachers like Maureen encouraged pupil participation in lessons but the interaction remained at the surface level. Pupils responded to teachers' questions, but their ideas made little difference to the planned trajectory of the lesson. Lessons were tightly structured and the teaching was often not directly contingent on pupils' responses. When pupils gave unexpected responses during the lesson, these teachers found it hard to think on their feet. They also reported difficulty in anticipating potential responses in advance and in identifying productive teaching strategies to overcome these. Such anticipation did not form part of their lesson planning. Their pedagogical

knowledge appeared to be neither sufficiently extensive, explicit nor primed to be available to them in the moment to help them to recognise what the pupil was thinking and thus the opportunity to confront misconceptions or introduce more advanced mathematical ideas was often missed. Their dominant modes of interaction could be characterised as rigid scaffolding with funnelling questioning and surface interaction. The performance of their classes was little different from their controls.

In contrast, teachers like Fiona often planned to use common misconceptions as the basis of problematics, to provoke cognitive conflict and argumentation. Scaffolding was dynamic and contingent on pupils' ideas. The classroom discourse was generally dialectic in nature, invoking deep interaction. Ideas were taken as conjectures which were open to challenge and debate. Uptake questioning was regularly used to encourage articulation and to develop pupils' ideas. Attention was focused on key points in pupils' explanations and the importance of pupils understanding each other's ideas was emphasised. Pupils were expected to seek clarification of points which were unclear, to identify errors (some of which were deliberately made by the teachers) and to comment constructively on tentative ideas. These teachers exploited the potential affordances of the moment in the dynamic situation of the classroom to enhance learning. Their pupils had a high degree of autonomy and responsibility for their own learning. They were expected to contribute actively towards the co-construction of mathematical knowledge, scaffolded by the social discourse of the lesson. Such approaches contributed to the creation of a collaborative community of inquiry. In addition, such approaches also provided opportunities for pupils to reflect in action on their learning. These teachers also demanded participation in collective reflection on learning, for example during regular plenaries, during which pupils' explanations and alternative strategies were often used as objects of reflection. Their dominant modes of interaction could be characterised as dynamic scaffolding and reflective discourse. Their classes were markedly better than their controls.

This study supports the efficacy of dialogical approaches utilising reflective discourse for the development of numeracy. However, these deeper forms of interaction require not only a high level of pedagogical knowledge and skill, but also a willingness to explore and respond to pupils' thinking and engage them in the co-construction of knowledge. For many teachers, this represents a challenge to current practices. Significant support would be needed to achieve such a profound change.

## References

- Alexander, R. (2005). *Towards Dialogic Teaching: Rethinking Classroom Talk*. York: Dialogos UK Ltd.
- Bauersfeld, H. (1988). Interaction, construction and knowledge: alternative perspectives for mathematics education, In D. Grouws, T. Cooney, & D. Jones (Eds.), *Effective Mathematics Teaching* (pp.27-46). Reston, VA: Lawrence Erlbaum.
- Cobb, P., Boufi, A., McClain, K., & Whitenack, J. (1997). Reflective discourse and collective reflection. *Journal for Research in Mathematics Education*, 28(3), 258-77.

- DfEE (1999). *The National Numeracy Strategy: Framework for Teaching Mathematics*. Cambridge: Cambridge University Press.
- DfEE, (2001). *Key Stage 3 National Strategy: Framework for Teaching Mathematics: Years 7, 8 and 9*. London: DfEE.
- Galton, M., Hargreaves, L., Comber, C., Wall, D., & Pell, A. (1999). Changes in patterns of teacher interaction in primary classrooms: 1976-96. *British Educational Research Journal*, 25(1), 23-37.
- Hargreaves, L., Moyles, J., Merry, R., Paterson, F., Pell, A., & Esarte-Sarries, V. (2003). How do primary school teachers define and implement 'interactive teaching' in the National Literacy Strategy in England? *Research Papers in Education*, 18(3), 217-236.
- Jones, S. (2008). *Reflective Discourse and the Effective Teaching of Numeracy*. Unpublished PhD thesis: University of Wales Swansea.
- Mathematical Association (1992). *Mental Methods in Mathematics: A First Resort*. Leicester: The Mathematical Association.
- Mercer, N. & Sams, C. (2006). Teaching children how to use language to solve maths problems. *Language and Education* 20(6), 507-528.
- Moyles, J., Hargreaves, L., Merry, R., Paterson, R., & Esarte-Sarries, V., (Eds.) (2003). *Interactive Teaching in the Primary School: Digging Deeper into Meanings*. Maidenhead: Open University Press.
- Mroz, M., Smith, F., & Hardman, F. (2000). The discourse of the literacy hour. *Cambridge Journal of Education*, 30(3), 379-390.
- Ryan, J. & Williams, J. (2007). *Children's Mathematics 4 - 15: Learning from Errors and Misconceptions*. Maidenhead: Open University Press.
- Sherin, M.G. (2002). A balancing act: Developing a discourse community in mathematics classrooms. *Journal of Mathematics Teacher Education*, 5, 205-233.
- Sinclair, J. & Coulthard, R. (1975). *Towards an Analysis of Discourse*. Oxford: Oxford University Press.
- Smith, F., Hardman, F., Wall, K., & Mroz, M. (2004). Interactive whole class teaching in the National Literacy and Numeracy Strategies. *British Educational Research Journal*, 30(3), 395-411.
- Tanner, H. & Jones, S. (2000). Scaffolding for success: Reflective discourse and the effective teaching of mathematical thinking skills. In T. Rowland and C. Morgan (Eds.), *Research in Mathematics Education volume 2: Papers of the British Society for Research into Learning Mathematics* (pp19-32). London: BSRLM.
- Tanner, H., Jones, S., Kennewell, S., & Beauchamp, G. (2005). Interactive whiteboards and pedagogies of whole class teaching. In *Proceedings of MERGA 28, Mathematics Education Research Group of Australasia Conference*. Melbourne, Australia: MERGA. Retrieved January 14, 2008 from <http://www.merga.net.au/documents/RP832005.pdf>

# TEACHERS OF LATINO STUDENTS REFLECT ON THE IMPLEMENTATION OF A MATHEMATICAL TASK

Leslie H. Kahn

The University of Arizona

Sandra I. Musanti

The University of New Mexico

Laura Kondek McLeman

The University of Arizona

José María Menéndez-Gómez

The University of Arizona

Barbara Trujillo

The University of New Mexico

*Teachers in two multi-grade study groups in elementary schools with large populations of Latino students reflect on the implementation of an open-ended mathematical task. In this research, interviews and study group discussions provide the teachers' reflections on the implementation of the task and on their practices in general that create learning environments for their Latino students. Multiple categories representing the teacher reflections were developed and our focus is on those practices that teachers consider effective and specific factors that impact practice. The design of this study proved to be especially useful in promoting teacher reflective conversation.*

## INTRODUCTION

The purpose of the paper is to present findings across two elementary teacher study groups affiliated with research conducted by the Center for Mathematics Education of Latinos/as (CEMELA)<sup>1</sup>. The Center investigates the connections between mathematics, language and culture. Therefore, for this study we are interested in the reflections of teachers who work predominantly with Latino students in the context of the classroom implementation of a mathematical task. Especially, we explore teachers' reflections in about issues of language and culture in relation to students' mathematical understanding. The task of choice was an open-ended geometry problem written for fourth grade students, selected from the National Assessment of Educational Progress (NAEP). In providing this task and giving teachers opportunities to reflect on its implementation, we asked: What do teachers of Latino students reflect on as they discuss their mathematics instruction? This study contributes to the emerging literature on mathematics professional development for teachers of Latino students.

## THEORETICAL FRAMEWORK

Research indicates that reflection about practice should be a central component of teacher professional development (Freese, 1999; Manouchehri, 2002), and that teachers benefit from experiences that foster collective construction of knowledge about subject matter, students and pedagogy (Ball & Cohen, 1999). Reflection opens teachers' possibilities to revisit teaching and make meaning of the different

---

<sup>1</sup> This research was supported by the National Science Foundation under grant ESI-0424983. The views expressed here are those of the authors and do not necessarily reflect the views of the funding agency.

dimensions of practice, creating opportunities for change by providing opportunities to examine thoughts and actions. Schön (1983) explains that practitioners make meaning of their experiences and actions by building understanding of the assumptions embedded in their practices, making them explicit, critically analyzing them, and later integrating them into new actions. In the context of our Teacher Study Groups (TSGs), reflection on practice becomes central to teachers' learning process and it is the focus of our study.

## **RELATED LITERATURE**

Two bodies of literature inform this study. First, we draw from research that highlights the potential of learning communities in which teachers reflect on their classroom practices and carefully consider the context in which their students' mathematical explorations take place and the resulting student work (Ball & Cohen, 1999; Franke & Kazemi, 2001; Kazemi & Franke, 2004). TSGs, as learning communities, create the context for teachers to reflect and collaborate on constructing mathematical understanding of their teaching practices and students' mathematical learning (Crespo & Featherstone, 2006). It is within the context of reflection within teacher study groups, that this research is framed.

Second, our study is informed by research supporting instructional practices where students have opportunities to communicate and consolidate their understandings of mathematics. The expectation is that students will analyze, make conjectures, evaluate the mathematical strategies presented by others, and use mathematical language to express their ideas (NCTM, 2000). Khisty's (1997) research furthers our understanding on teaching practices that support Latino students and second language learners in the mathematics classroom, by suggesting teachers understand multiple factors that influence group interactions such as "teacher discourse and learning environments that promote student talk." (p. 295)

## **METHODS**

### **Participants**

Two multi-grade, elementary TSGs at two universities in two different states in the Southwest of the United States engaged teachers in reflection of their own mathematical knowledge and practice as it relates to Latino students. Teacher study group 1 (TSG1) involved 8 K-5 (5 to 10 year-olds) teachers, from three different schools. Their classroom experience ranged from 5 to 20 years. The group integrated 2 male and 6 female teachers, where 5 of the teachers were Latino/as and the rest were Caucasian. All but two of them taught in schools serving predominantly Latino students in low socio-economic communities with a high percentage of English language learners (ELLs). Teacher study group 2 (TSG2) involved 9 teachers of grades 3-6 and 1 gifted and talented (GATE) teacher from three different schools. These teachers included 7 Latino and 3 Caucasian females and ranged from 3 to 27 years of classroom experience. The schools had, on average, a 90% Latino student population, with 31% of the students classified as ELLs.

During the school year 2006-07, TSG1 met twice a month for 2 hours each session. This study group explored a framework to rethink the integration of problem solving into their mathematics curriculum. Teachers engaged in exploring mathematical problems, analyzed samples of students' work produced during classroom implementation of different problem solving activities, and discussed related literature provided by TSG facilitators or participating teachers. During the same time frame, TSG2 met a total of nine times each semester with each meeting lasting approximately one and a half hours. The participants of this study group explored mathematical tasks as learners, reflected on their practice and engaged in analyses of student work as it related to mathematics content.

## **Design**

Researchers jointly designed a professional development experience that would invite teachers in both TSGs to reflect on the adaptation and implementation of a "rich mathematical task" (Crespo & Featherstone, 2006, p. 99). The task selected was a geometry measurement problem from the fourth grade 1996 NAEP. Several reasons explain the selection of this NAEP task. First, even though Latino students are outperformed by white students on the measurement strand of the NAEP (Lubienski, 2003), studies show that Latino students can participate meaningfully through their mathematical discourse (Anhalt, Fernandes, & Civil, 2007). In addition, this particular 'comparison of areas' task would allow students to use a variety of strategies to solve the problem, and teachers to think about (a) the mathematical concepts students need to understand, (b) issues of language involved in comprehending tasks, and (c) materials/tools that support students' understanding.

Our design has elements in common with the SATRR model (Crespo & Featherstone, 2006) in which teachers engage in collective inquiry. First, teachers explored the task as mathematical learners and then discussed possible challenges students might encounter regarding language and mathematical understanding. Next, teachers at each site implemented the task in their classrooms, adapting it to fit the needs of their specific students. Finally, teachers reflected on the task implementation and focused on the students' language and mathematical understandings. An important expectation guiding this design was that teachers would be prompted to reflect on how they adapt instruction and make decisions on the appropriate instructional approach considering different aspects of students' needs.

## **Data Collection and Analysis**

Data collection included videotaped study group sessions at each site (pre and post classroom implementation), videotaped selected classroom sessions during task implementation (three sessions at each site), and follow-up semi-structured interviews with the teachers whose task implementation was videotaped (three interviews at each site). The interviews were designed to provide teachers with the opportunity to reflect back on different aspects of the task implementation, especially (a) the task introduction, (b) the materials provided to students to work on the task,



and (c) the different strategies students used to work on the task and some of the challenges they confronted. To achieve this purpose, each videotaped classroom session was watched several times, and relevant scenes were selected to highlight the different aspects of the task implementation. Each teacher interview involved a similar set of questions, some of which were illustrated by selected video scenes shown during the interview process as a means to prompt reflection on the different aspects of the task implementation.

Initially, the two research teams individually openly coded (Strauss & Corbin, 1998) the transcripts of the follow-up interviews and the study group session after the task implementation, looking for themes in the teachers' reflections. Teams of researchers, collectively and individually, repeatedly refined the emerging codes. With the help of TAMS Analyzer, a computer-based qualitative research tool, the following seven categories were developed: (a) Teachers' expectations, (b) Factors that impact practice, (c) Practices considered effective, (d) Issues raised about students or practice, (e) Knowledge of students, (f) Recognition teachers have about their practice, and (g) Teachers' notions about teaching and learning.

## **RESULTS**

In analyzing teachers' reflections and subsequently organizing them into categories, two themes emerged from the data. Teachers reflect mainly on: (a) the multiple practices they consider effective in teaching and supporting their students to achieve mathematical understanding, and (b) the factors impacting their work in the classroom. It is important to notice that the categories are not exclusive and they inform each other. For instance, what teachers consider an effective practice strongly relates to their knowledge of the students, their expectations, and their notions about teaching and what ELL students need to learn.

### **Reflections on Practices that Foster Mathematical Understanding**

Teachers from both TSG1 and TSG2 reflected on what practices were more typical and important in their instruction and that seemed to be more effective to promote Latino students' mathematical understanding. Among these practices, teachers identified: using appropriate mathematical vocabulary, the importance of creating learning situations that foster peer interaction, supporting students to become active thinkers and independent decision makers, providing varied materials and resources to solve problems, and supporting student learning through the review of concepts, the validation of their responses and strategies, and using students' native language when needed. Teachers' words clearly illustrate the significance of the most relevant practices identified at both TSGs:

1. About the importance of developing students' academic language and using appropriate mathematical vocabulary, Ms. Alvarez (TSG2) explained:

I think about the language. As I'm saying things I'm trying to think of the correct language. And to make sure that I'm using the mathematical terms . . . so I go slow

because I'm always trying to think of how to say it correctly and using the vocabulary, so that they in turn will use it also.

2. In relation to developing students' mathematical vocabulary and the need of using their native language as a way to support students' learning, Ms. Salas (TSG1) commented:

A lot of the kids in here would need [Spanish] and it would help them. And because you just can't give it to them all in English because then it would hinder their learning. This way you explain both English and Spanish and "I can do that, I understand what she is talking about now..."

3. Teachers underscored the importance of creating learning situations that would encourage students to interact and learn from each other. They drew on the belief that students benefit from collaborative work within problem solving contexts. Mr. Sloan, (TSG1) explained:

If the environment is set up correctly, the children will learn just as much or more from each other than they will from your instruction, ... in something like this, I remember there were a couple of places where kids were doing as well or better a job than I would be doing explaining to another child how they got the answer.

4. Related to valuing student interactions, teacher's emphasis is on promoting learning situations that would support students to be active thinkers and to develop and apply higher thinking skills that they could transfer to other situations in which they are required to problem solve. Ms. Alvarez (TSG2) explained her expectations:

I want them to be able to think on their own. I've always told them, when you are solving a problem try and, I try and teach them different ways, different strategies, to solve something. And I want them to be able to reason and think, okay here I have a problem, what can I do to figure this out?

### **Reflections on Factors that Influence Practice**

Data indicated that among the most influential factors on what teachers teach, what they do in the classroom, and what they consider relevant for students learning are (a) the adopted reform curriculum; (b) their knowledge of students in terms of dispositions for learning, language, prior knowledge, and mathematical understanding; (c) their previous personal and professional experiences as learners and teachers of mathematics; (d) their expectations or what they value for students to learn and understand; (e) the TSG professional development experience.

It is important to notice that both groups of teachers identified the adopted reform curriculum as their referent to decide what to teach. However, other factors seemed to have significant influence in their practice. These teachers reflected on the importance to have high expectations and to build knowledge about their students, especially to be able to understand what students are able to accomplish, what their struggles are, and what they know that might help them to be successful with problem-solving.

Mr. Sloan (TSG1) thinks that teachers

should never go into something with a... predetermined notion of whether or not the kids will be able to solve the problem. My attitude is... anything I give them they should be able to do it, and if they can't do it immediately then maybe you just need to . . . give them a few more tools, a little more background knowledge. But I think way too often we kind of have preconceived notions of what they're capable of and so they'll live up to those expectations. So if they are low expectations, they live up to them.

Teachers' personal, educational, cultural and linguistic experiences, as well as their experiences in the classroom, seemed to affect the way they perceived effective teaching and the conditions that foster students' learning. Ms. Alvarez's (TSG2) memories illustrate this point:

You know we didn't grow up that way. Where we had ... to memorize everything, and some things I'm learning along with them. I told them, you know I memorized, like when we were working with fractions, especially with division I told them, you know all I memorized, was you turn them and you multiply. And I go "I didn't understand why. And now you guys are lucky because you are understanding 'why,'" and I learned along with them.

Professional development was a relevant factor affecting the way teachers interpreted students' work and the instructional decisions they made to provide for students' learning needs. Teachers raised questions, expressed doubts, and understandings they have gained through the TSG process. For instance, Ms. Segovia (TSG1) and Ms. Castillo (TSG2) revisit their practices based on their insights of students' understandings:

You see what they did and what they didn't get and it shows you how you taught it or what you didn't teach, ... for some reason they just didn't understand it the way you taught it. Or maybe something in your thinking, [you need to ask yourself], what am I not doing? Do I need to go back and review myself to see what's missing? (Ms. Segovia)

I've learned ... that the kids don't have to have the one way to solve things. I used to just think it was just one way of solving. Because that's the way I learned you know. And now to find all these different ways of solving one problem, I think it's just amazing (Ms. Castillo).

## **DISCUSSION**

This exploratory study contributes to the growing literature on mathematics professional development for teachers of Latino students. Teaching mathematics to Latino students is a complex endeavor and teachers need meaningful professional development activities that open the space for in depth reflection on their practice, the content they teach, and its impact on students' mathematical understanding (Crespo & Featherstone, 2006; Téllez, 2004).

Particularly relevant from our study is that teachers reflected on language specifically referring to teachers' use and students' development of appropriate mathematical vocabulary. Teachers referred to their decisions as educators to make this aspect of

language in their classroom highly visible. Additionally, teachers reflected on their practice of using Spanish to support students' mathematical understanding. Teachers at both sites explain how the use and incorporation of Spanish into their mathematics teaching supports students' comprehension of mathematical concepts (Khisty, 1997). However, it is significant to note that, although the purpose of the TSG implementation task was for teachers to discuss elements of culture and issues of language regarding students' mathematical understanding, there were very few instances in which teachers referred to the impact of students' language and culture as an integral part of the teaching and learning process. We find this intriguing and deserving of further exploration.

Teachers underscored the importance of creating learning situations that promoted Latino students to become active, independent thinkers who would apply higher thinking skills that would transfer to other situations. In these discussions they talked about students choosing materials on their own to support their problem solving efforts, the importance of fostering multiple opportunities for working with peers, and the role of students talking with each other. Implementing the NAEP tasks involved a process of decision making about what materials to make available or not during the process of solving the task. In general teachers seemed to support the idea of making available different types of materials and allowing children to decide what to use (graph paper, scissors, white boards, four shapes or two shapes). However, some teachers did not articulate why this practice would support students' problem solving and how their own instructional decisions provided that support.

Finally, data offered valuable evidence on the importance of professional development that fosters ongoing opportunities for teachers to reflect on a concrete task and its impact on students' mathematical understanding. In coherence with research in the field (Crespo, 2006; Franke & Kazemi, 2001), teachers valued the opportunities to examine student work generated through a common task. It was important for teachers to reflect on the outcomes of a NAEP task because it afforded teachers the occasion to think about what their students were able to accomplish with the adequate support (Anhalt et al., 2007).

## References

- Anhalt, C., Fernandes, A., & Civil, M. (2007). Exploring Latino Students; Understanding of Measurement on NAEP Items. In T. Lamberg & L.R. Wiest (Eds.), *Proceedings of the Twenty Ninth Annual Meeting of the North American Chapter of the International Group for the Psychology of Mathematics Education*. Stateline (Lake Tahoe), NV: University of Nevada, Reno.
- Ball, D. L. & Cohen, D.K. (1999). Developing practice, developing practitioners: Toward a practice-based theory of professional education. In G. Sykes & L. Darling-Hammond (Eds.), *Handbook of Policy and Practice*. (pp. 3-32). San Francisco: Jossey Bass.
- Crespo, S. & Featherstone, H. (2006). Teacher learning in mathematics teacher groups: One math problem at a time. *AMTE Monograph, 3. The Work of Mathematics Teacher Educators*. 97-115.

- Franke, M. L. & Kazemi, E. (2001). Teaching as learning within a community of practice: Characterizing generative growth. In T. Wood, B. Nelson, & J. Warfield (Eds.), *Beyond Classical Pedagogy in Elementary Mathematics: The Nature of Facilitative Teaching* (pp. 47-74). Mahwah, NJ: Lawrence Erlbaum Associates.
- Freese, A. R. (1999). The role of reflection on preservice teachers' development in the context of a professional development school. *Teaching and Teacher Education, 15*, 895-909.
- Kazemi, E. & Franke, M.L. (2004). Teacher learning in mathematics: Using student work to promote collective inquiry. *Journal of Mathematics Teacher Education, 7*, 203-235.
- Khisty, L. L. (1997). Making mathematics accessible to Latino students. Rethinking instructional practice. In *NCTM Yearbook: Multicultural and Gender Equity in the Mathematics Classroom: The Gift of Diversity* (pp. 92-101). Reston, VA: NCTM.
- Lubienski, S. T. (2003). Is our teaching measuring? Race-, SES-, and gender-related gaps in measurement achievement, *Learning and Teaching Measurement 2003 Yearbook I* (pp. 282-292). Reston, VA: NCTM.
- Manouchehri, A. (2002). Developing teaching knowledge through peer discourse. *Teaching and Teacher Education, 18*, 715-737.
- National Council of Teachers of Mathematics. (2000). *Principles and Standards for School Mathematics*. Reston, VA: NCTM.
- Schön, D. A. (1983). *The Reflective Practitioner: How Professionals Think in Action*. New York: Basic Books.
- Strauss, A. & Corbin, J. (1998). *Basics of Qualitative Research. Techniques and Procedures for Developing Grounded Theory* (2nd ed.). Thousand Oaks, Ca: Sage.
- Téllez, K. (2004). Preparing teachers for Latino children and youth: Policies and practices. *The High School Journal, 88*(2), 43-54.

# WAYS OF REASONING: TWO CASE STUDIES IN AN INQUIRY-ORIENTED DIFFERENTIAL EQUATIONS CLASS

Karen Allen Keene

North Carolina State University

*The purpose of this paper is to elaborate the results of research conducted on student reasoning in an inquiry oriented differential equations class. Students reasoned to justify their conclusions during task-based instructional interviews and in whole class and small class discussions. Analysis of these types of reasoning as students developed understanding of solutions to linear systems of differential equations sheds light on student thinking at the university level, as well as pointing to new understandings of student thinking at the primary and secondary level.*

## INTRODUCTION

During the last ten to fifteen years, a dynamical systems approach to teaching and learning differential equations has become more common in North American universities. This approach involves students' focusing on the physical processes of phenomena, the complex interaction between variables in a system as they vary over time, and analysis of the systems' numerical and qualitative (graphical) solution representations. In many differential equation classrooms teachers are reducing class time spent recovering the closed form solutions for special types of differential equations and systems of differential equations (those equations that can be solved analytically) and emphasizing numerical and graphical ways to analyse the solutions to differential equations (Blanchard, Devaney & Hall, 1995). According to Kallaher (1999), "today, differential equations can be taught from the qualitative point of view with emphasis on the underlying mathematics and physical processes that give rise to the equations" (p. vii).

What do we know about student reasoning in dynamical systems? Below I first briefly discuss what research tells us about student understanding of one particular kind of dynamical system (linear systems of two differential equations). Then, I discuss the results of two case studies of students studying differential equations in an inquiry-oriented tertiary level classroom. The analysis of the research indicated that students used several types of reasoning as they develop understanding of the solutions to these dynamical systems. The types of reasoning they use are: dynamical reasoning, algebraic reasoning, reasoning with prior knowledge, graphical reasoning, and reasoning with the context.

## PRIOR RESEARCH.

Researchers are beginning to study students' understanding of systems of differential equations. In one study, Trigeuros (2000) investigated student learning of systems of differential equations in two differential equations classes at a small private university in Mexico. Her analysis of the interviews revealed that some students had

problems interpreting the meaning of equilibrium, interpreting the meaning of a point in phase space, and seeing the dependence of time in the phase space. Students in her study also showed a tendency to focus on just part of the information provided by phase portraits. Only a few students analysed long-term behavior of solutions in relation to equilibrium solutions. Trigueros (2004) also reported on students' understanding of straight line solutions to a linear system of differential equations. She conducted interviews with 12 students after instruction on solutions to systems and reported that only one had a complete understanding of straight line solutions as analysed using a framework that places student work into a categorization of inter, intra, and trans modes of understanding. Her primary conclusion was that few students exhibit a strong understanding of solutions to differential equations. Unfortunately, she does not provide more analysis into why this might be, an area that this research report will address.

Whitehead and Rasmussen (2003) proposed that students could reason about and develop conceptualizations for systems of differential equations using mental operations. They documented students' use of conception of rate as a reasoning tool, students using quantification as a mental operation, and third, students enacting what they called a function-variable scheme in their efforts. This earlier research on student understanding of systems is refocused as mathematical activity instead of mental understandings.

Other research on differential equations learning has also been reported and it has significance because it provides some background on student understanding in differential equations (Artigue, 2002; Rasmussen, 2001, Yackel & Rasmussen, 2002, Rasmussen & Marrongelle, 2006). Prior research on individual student learning has primarily focused on first order differential equations conceptions and misconceptions. This paper focuses on the lesser studied area of system of differential equations.

## **METHODOLOGY**

Eighteen students were initially enrolled in the class where the research was conducted, and of these 18, 11 completed the course. The 11 students that completed the semester were all male mathematics or engineering majors with a wide variety of ages. There were 2 females and 5 males who did not complete the course. Several of the students were considered non-traditional in that they were older and had returned to school to pursue degrees, not having entered university directly from high school. More than half of the students were working full time and attending class in the evening.

The data that was collected consisted of videotaping of the 9 class sessions where instruction on systems of differential equations was conducted. All student work, including tests, journals, and in class task sheets were collected. In addition, two interviews (before and after instruction) were designed and conducted with 6 of the students in the class, including the two that I ultimately used for a case study.

Both Adam and Brandon had been in small groups that were videotaped during the entire semester and had been interviewed before and after instruction on systems of

differential equations. Adam was chosen as one of the two students for the following reasons. He was majoring in mathematics and one of the academic leaders of the classroom. He was very comfortable with his ideas and not afraid to come to the front of the class to present his arguments. He also was the person who shared his thinking the most in his small group, although the other group members did challenge and push his thinking during those small group times. He often asked questions of other students on the other side of the classroom. Finally, he was not afraid to make a claim about his thinking even if he was not sure he was correct and publicly argue for his claim while being comfortable with changing his statement when provided with an argument that convinced him.

Brandon was chosen to be the second case study for different reasons. First of all, Brandon was a non-traditional student that had returned to university to obtain a bachelors degree in engineering, even though his job involved significant engineering tasks already. He was taking the course at night as he worked full time and this was one of two night classes in which he was enrolled. His ways of participation in the class varied significantly from Adam. His mathematical activity was much more private in general, as was observed by the amount of homework he turned in compared to his class participation. He spoke less than half as many times as Adam did and it was often to offer concerns or lack of confidence in his own mathematical thinking. He was more involved in the mathematical activity in his small group, although one of the members of his small group was more vocal.

Analysis of the data was based on a grounded theory approach (Glaser & Strauss, 1967) and was begun by transcribing all whole class discussions, selected small group discussions which Adam and Brandon were involved in, and all individual interviews conducted with the two students. I examined the discourse and written work, looking for ways of reasoning by the students. I used open coding to identify classifications for the reasoning in the classroom and general themes were identified. I then used this open coding and conducted another pass through the dialogue using the constant comparison method (Lincoln & Guba, 1985) and more finely tuned the classifications. Written work was used to triangulate the results and verify the analysis from the discourse. Connections to previous literature and the new ideas that emerged were recognized and documented.

## **ANALYSIS**

I focus in this report on the ways of reasoning that emerged as bigger themes in the development of new conceptualizations of systems of differential equations, their representations and their solutions. The ways of reasoning can not in practice be separated and it is somewhat artificial to attempt to place reasoning in categories. However, in order to develop a “terrain” of the different forms of reasoning about systems of differential equations, it is useful to discuss these categories separately. I present five themes for ways of reasoning that Brandon and Adam used: dynamical reasoning, reasoning with prior knowledge, graphical reasoning and dynamic



visualization, reasoning with the context, and algebraic reasoning. These are briefly discussed in this short paper, but will be elaborated in the full paper.

**Dynamical Reasoning:** Dynamical reasoning is defined as developing and using conceptualizations about the dynamic quantity time as it implicitly or explicitly coordinates with other quantities to understand and solve problems (Keene, 2007). Described in another manner, the use of parametric reasoning occurs when students use their understanding of time to reason about mathematical quantities. This characterization may be useful more broadly because reasoning about and with time as a dynamically changing parameter supports mathematical activity related to graphing and working with parametric equations in precalculus and calculus as well as mathematical activity in other courses that involve time as the independent variable; this includes problems about motion that occur in middle school and high school. With Adam and Brandon, they reasoned about time in each class session as well as during their interviews. They brought an intuition about time that provided basic reasoning for their thinking about solutions as the solutions were identified as graphs that are created as time passes.

**Reasoning with Prior Knowledge:** As Adam and Brandon participated in the class discussions, there were many instances that demonstrate reasoning about solutions using prior knowledge. The knowledge they used came primarily from three areas of mathematics: first order differential equations, rate of change understanding, and linear (or vector) algebra.

Because of the design of the instructional sequence in this inquiry oriented differential equations class, it is not surprising that the students significantly reason with ideas from the first half of the semester. Specifically, students use the understanding that solutions to autonomous differential equations are shifts along the  $t$  axis and that there is a structure of the solution space. This notion of shift led to one of the primary conceptions in the class, that of the plane of straight line solutions, where the plane is made up of all the straight line solutions that lie on one of the straight lines in the phase plane. Also, equilibrium solution functions are conceptualized for systems based on equilibrium solution functions for single differential equations. Students grow to understand that the equilibrium solution is represented by a line in space with equations  $x(t)=a$  and  $y(t)=b$ , where  $a$  and  $b$  are constants. This understanding expands on first order equilibrium solutions, which are horizontal lines in a plane with equations  $y(t)=$  “constant.” Finally, the knowledge that  $dx/dt=kx$  has a solution of the form  $x(t)=ae^{kt}$  is used to understand straight line solutions of systems in space after algebraically manipulating the system to create differential equations that can be solved by separation of variables.

Students’ understanding of the concept of rate of change is used before, during, and after instruction on systems. Brandon and Adam both used rate of change, both in thinking about structure of solutions, and in reasoning with derivative. Several times in the case studies, Adam talked about concavity of solutions and how solutions

behave. He used his understanding of how rate (or speed, as he sometimes stated) is changing to discuss these solutions. Rate of change is one of the primary conceptions that the instruction sequence is built on, and so using the differential equations as an expression of rate is important as well. Also, derivative is instantaneous rate of change and several times the students reasoned qualitatively using derivative. The relationship between an increasing and decreasing function and the sign of the derivative is especially important in their thinking.

Finally both in the development of the phase plane as a reasoning tool, and the development of solutions to linear systems, Brandon and Adam used their understanding from linear (vector) algebra. In the phase plane reinvention, the students' vector conceptualization both supported and constrained new understandings. Vector addition and the ideas of vector magnitude and angle are not helpful, but components of vectors and their projections onto different planes or lines were important in developing ideas about the phase plane.

**Graphical Reasoning:** The third theme of student reasoning is graphical reasoning and dynamic visualization. The conceptualizations of solutions are first based on students' developing an understanding that a solution to a system is best considered as a curve in space. The mathematical activity promotes this idea, specifically the computer explorations. Adam and Brandon both developed the idea that this curve in space can be thought of as the "mother curve," as in, it is the curve from which the other representations can be generated. The  $x(t)$ ,  $y(t)$  and phase plane representations are visualized both by imagining through expansion of visualization and by investigating these solutions using a computer program.

Adam and Brandon continued to reason graphically as they developed an understanding of the phase plane. Lines and vectors on a plane can be visualized and graphical reasoning provided support for them to understand the phase plane and then representations of solutions on the phase plane. As the nine classes progressed, Adam then expanded this visualization into straight line solutions in space. His visualization of exponential functions in space particularly supported his and the class's understanding of these solutions and the development of the space of solutions.

**Reasoning with the Context:** Because of the instructional design theory Realistic Mathematics Education (Gravemeier, 1994) that was used as inspiration to develop the instructional materials used in the teaching, students used the real world scenarios in the materials to understand and use solutions to systems of differential equations. There were two primary real world scenarios used in the sequence, population growth, and the spring-mass situation. Both of these provided knowledge that Brandon and Adam used to grow in their understanding.

Population contexts are integrated into the entire differential equations class, but in the five week unit on systems, students were able to reason with a cooperative and competitive model for two populations, and the predator-prey model for two populations. Both Adam and Brandon used knowledge of these situations in the first

interview, and continued to do so during instruction. The reasoning specifically supports sense making in that when they use prior knowledge about derivative or graphical reasoning, for example, knowledge about the real world scenario is at times used to check and make sure that their results are reasonable. Also, they sometimes began with the real world scenario to conjecture what should happen and then verified or refuted these conjectures with one of the other three forms of reasoning characterized in this section.

The spring-mass situation, which involved a mass on a spring being pulled or pushed along a linear path and, can be modelled with a system of differential equations. Brandon used his engineering experience to reason about the system model and its solutions extensively through his understanding of the physical situation. He discussed the system model for the spring mass in whole class discussion at its introduction into the class activity and refers back to the situation during continued growth. Both students also reasoned with the spring mass scenario when straight line solutions were introduced. The contradiction between what they believed the behavior of the mass to be and the phase plane representation of the behavior (a solution to the system) supported the reconceptualization of the spring mass behavior and then this reconceptualization supports new understanding about solutions to systems of differential equations.

**Algebraic Reasoning:** The final theme for reasoning in the case studies is algebraic reasoning. Algebraic reasoning has been elaborated extensively in the mathematics education literature (e.g., Arcavi, 1994; Kaput, Blanton, and Arnella, in press; Chazan, 2000) but there is no one agreed upon formal definition of what constitutes algebraic reasoning. For the purpose of this analysis, I characterize algebraic reasoning as developing, manipulating, understanding, and interpreting symbolic representations. Students use algebraic reasoning throughout the five weeks of instruction, but this reasoning is used more at the end of the sequence.

Brandon and Adam used algebra in the middle of the instruction to find straight line solutions. However, in this case, the algebraic reasoning did not support new understandings and tended to constrain growth in conceptualizations. After the students understood why straight line solutions can be found by setting slopes of lines and vectors equal to each other, then they used algebraic reasoning to find and interpret the solutions and then to find the general solutions using linear combinations. Brandon was especially comfortable with this reasoning and he contributed significant algebraic ideas in the last three days where the focus was on finding the general solutions and understanding the symbolic representations.

Algebraic reasoning also complemented some of the reasoning with earlier knowledge, specifically linear algebra. It is impossible to separate use of prior knowledge about linear algebra and algebraic reasoning, but manipulation of symbols and interpretation of their meaning played a role in vector understanding and use.

## DISCUSSION AND CONCLUSION

The identification of these different types of reasoning when learning mathematics at the tertiary level is important in mathematics today as they reveal ways for those teaching and learning to begin to focus on student understanding. The evidence that was identified in the analysis of these two students learning systems of equations was also evident when looking at the other students in the class. However, it should be noted that the instructional materials and inquiry-based classroom environment allowed this analysis to be done, because the students were required to participate in the discourse of the class and routinely explain and justify their reasoning. This allowed the author to confirm that using prior knowledge, algebraic reasoning, dynamical reasoning, graphical reasoning, and reasoning with content as ways that students grew to understand the concept of a solution to a differential equations and how to solve linear systems. Further research is warranted to determine if this is consistent across other inquiry based differential equation classrooms. Also, research on if these five ways of reasoning are consistent in other classrooms is needed.

## References

- Arcavi, A. (1994). Symbol sense: Informal sense-making in formal mathematics. *For the Learning of Mathematics*, 14 (3), 24-35.
- Artigue, M. (1992). Cognitive difficulties and teaching practices. In G. Harel & E. Dubinsky (Eds.), *The Concept of Function: Aspects of Epistemology and Pedagogy*. (pp.109-132). Washington, DC: The Mathematical Association of America.
- Blanchard, P., Devaney, R., & Hall, R. (2002). *Differential Equations*. Boston: Brooks/Cole.
- Chazan, D. (2000). *Beyond Formulas in Mathematics Teaching: Dynamics of the High School Algebra Classroom*. New York, NY: Teachers College Press.
- Donovan, J. (2004). A first-order differential equations schema. In McDougall, D. & Ross, J. (Eds.), *Proceedings of the North American Chapter of the International Group for the Psychology of Mathematics Education*. Ontario, Canada.
- Gravemeijer, K.P.E. (1994). Educational development and developmental research in mathematics education. *Journal for Research in Mathematics Education*, 25(5), 443-471.
- Kallaher, M. J. ,(Ed.), (1999). *Revolutions in Differential Equations: Exploring ODEs with Modern Technology*, MAA Notes #50.
- Kaput, J., Blanton, M., & Armella, L. (in press). Algebra from a Symbolization Point of View. In Kaput, J. & Blanton, M. (Eds.), *Algebra in Early Grades*. Mahwah, NJ: Lawrence Erlbaum.
- Keene, K.A. (in press) A characterization of dynamic reasoning with Time as Parameter. *Journal of Mathematical Behavior*.
- Rasmussen, C. (2001). New directions in differential equations: a framework for interpreting students' understandings and difficulties. *Journal of Mathematical Behavior*, 20, 55-87.

- Rasmussen, C. & King, K. (2000). Locating starting points in differential equations: a realistic mathematics approach. *International Journal of Mathematical Education in Science and Technology*, 31(2), 161–172.
- Rasmussen, C. & Marrongelle, K. (in press). Pedagogical content tools: Integrating student reasoning and mathematics into instruction. *Journal for Research in Mathematics Education*.
- Smith, J. P. & Thompson, P. (in press). Quantitative reasoning and the development of algebraic reasoning. In Kaput, J. & Blanton, M. (Eds.), *Algebra in early Grades*. Mahwah, NJ: Lawrence Erlbaum.
- Strauss, A.L., & Corbin, J. (1990). *Basics of Qualitative Research: Grounded Theory Procedures and Techniques*. Newbury Park, CA: Sage.
- Trigueros, M. (2000). Students' conceptions of solution curves and equilibrium in systems of differential equations. In Fernandez, M. L. (Ed.), *Proceedings of PMENA-22* (pp. 93-97). Columbus, OH: ERIC.
- Trigueros, M. (2004). Understanding the meaning and representaiton of straight line solutions of systmes of differential equations. In McDougall, D. & Ross, J. (Eds.), *Proceedings of the North American Chapter of the International Group for the Psychology of Mathematics Education*. Ontario, Canada: ERIC.
- Yackel, E. & Rasmussen, C. (2002). Beliefs and norms in the mathematics classroom. In Leder, G., Pehkonen, E., & Toerner, G. (Eds.), *Beliefs: A Hidden Variable in Mathematics Education?* (pp. 313-330). Dordrecht, The Netherlands: Kluwer.

# ORCHESTRATING WHOLE-CLASS DISCUSSIONS IN ALGEBRA WITH THE AID OF CAS TECHNOLOGY

<u>Carolyn Kieran</u>	José Guzmán	A. Boileau and D. Tanguay	P. Drijvers
Université du Québec à Montréal	Cinvestav-IPN	Université du Québec à Montréal	Utrecht University

*This paper describes the practice of a 10th grade algebra teacher during whole-class discussions of equivalence of algebraic expressions some of which contain restrictions. The transcripts of the whole-class discussions were structured into a series of content-process cycles, with each shift in mathematical content signaling the start of a new cycle. Each cycle is also characterized by a particular role played by the CAS technology. The ways in which the teacher involved his students in discussing the mathematics of the task illustrates how algebra can be problematized with the aid of technology in whole-class discussions and thereby potentially lead to students' richer understanding of the mathematical content. The paper concludes with a synthesis of the strategies the teacher used to make the class discussions work.*

## INTRODUCTION AND RELATED LITERATURE

Since the advent of reform-based approaches to the teaching of school mathematics (NCTM, 1989), classroom discussion has been considered central to students' mathematical learning. However, teachers have admitted to finding it difficult to encourage discussion in algebra lessons, especially when the content involves the literal-symbolic and associated concepts and techniques (Sherin, 2002). Research interest in teaching practice, and the ways in which classroom discussion might be orchestrated so as to induce greater involvement and deeper mathematical learning on the part of students, is reflected in a few studies that have recently been carried out. These studies have focused on the role of, for example, teacher talk in the classroom (Boaler, 2003), teachers' revoicing of students' ideas within the context of classroom discussion (O'Connor, 2001), and norms that encourage mathematically-productive participation in classroom discussion (Yackel & Cobb, 1996).

Some of these studies have involved technology, in particular graphing technology (e.g., Doerr & Zangor, 2000; Huntley et al., 2000). Goos et al. (2003) noted that, when calculators and computers are permitted to become a part of face-to-face discussions, they facilitate communication and sharing of knowledge. One aspect of technology use that has been found to stimulate mathematical discussion in the classroom is the fact that the technology often surprises with unexpected representations or output (e.g., Hershkowitz & Kieran, 2001). However, none of this research has inquired into the particular combination of teaching practice, whole-class discussion, and CAS technology. In this regard, the research question that motivates the analysis presented in this paper is the following: *What is the nature of teaching practice that builds on the power of Computer Algebra System (CAS)*

*technology in order to problematize the mathematics that is discussed in the algebra classroom?* Problematizing the mathematics means making it open to discussion, that is, creating a mathematical arena in which one poses questions and tries to think deeply about the mathematics, including what might appear to be inconsistencies or contradictions and, in fact, using dilemmas provoked by the technology as a means to move one's thinking forward. This paper describes the practice of a 10<sup>th</sup> grade algebra teacher during whole-class discussions of equivalence of algebraic expressions some of which contain restrictions. The ways in which he involved his students in discussing the mathematics of the task, and in coordinating this with the related outputs provided by the CAS technology, illustrates how algebra can be problematized with the aid of technology in whole-class discussions and thereby potentially lead to students' richer understanding of the mathematical content.

## **THE STUDY**

This study is part of an ongoing program of research. The previous phase of our research, from which the data for this analysis were drawn, involved six 10<sup>th</sup> grade classes (15-year-olds), each of which was observed and videotaped over a five-month period. While student learning was the focus of the previous research (see, e.g., Kieran & Drijvers, 2006), it is teaching practice that is the current emphasis. The teacher whose practice is analyzed in this paper is one of the six initial teachers. We decided to start our analyses with this particular teacher because his interactions with the students were always supportive of their thinking; also he was a teacher whose eye remained on the mathematical horizon (Ball, 1993). He, a teacher of mathematics for five years, believed that it was important for students to struggle a little with mathematical tasks. He also encouraged his students to talk about their mathematics in class; he liked to take the time needed to elicit their thinking, rather than quickly give them the answers.

As a technique for structuring and analyzing our data in terms of teaching practice - practice aimed at encouraging whole-class mathematical discussion in CAS-supported algebra classes - we decided to use an approach that we adapted from Sherin (2002): We structured the transcripts of the whole-class discussions into a series of content-process cycles, with each shift in mathematical content signaling the start of a new cycle. Each cycle is also characterized by a particular role played by the CAS agent (Boaler, 2003).

## **ANALYSIS OF CYCLES OF WHOLE-CLASS DISCUSSIONS**

For the previous study, the research team had created several sets of activities that aimed at supporting the co-emergence of technique and theory. One of these sets of activities provides the context for this paper - equivalence of algebraic expressions and the role of restrictions in determining admissible values for the equivalence. At the start of the teaching sequence, numerical evaluation of expressions by use of the CAS served as the entry point. One of the main tasks here was the Numerical Substitution Task (Figure 1), where two numbers to be substituted were given and students were to

choose two others. It aimed at students' noticing that some pairs of expressions seemed *always* to end up with equal results. The task was followed by two reflection questions.

The task involved the following definition of equivalence of expressions:

We specify a set of admissible numbers for  $x$  (e.g., excluding the numbers where one of the expressions is not defined). If, for any admissible number that replaces  $x$ , each of the expressions gives the same value, we say that these expressions are equivalent on the set of admissible values.

The stress on the set of admissible numbers was made deliberately by the designers, so as to lead students to become aware of the attention that one has to pay to considering possible restrictions on the equivalence of expressions. Expression 5 in Figure 1 was a first example of this.

For $x =$		1/3	-5		
Expression		Result	Result	Result	Result
1.	$(x-3)(4x-3)$				
2.	$(x^2+x-2)(3x^2+2x-1)$				
3.	$(3x-1)(x^2-x-2)(x+5)$				
4.	$(-x+3)^2 + x(3x-9)$				
5.	$\frac{(x^2 + 3x - 10)(3x - 1)(x^2 + 3x + 2)}{x + 2}$				

Figure 1. Numerical Substitution Task.

The two reflection questions that followed were:

Question 1B: *Compare the results obtained for the various expressions in the table above. Record what you observe in the box below.*

Question 1C: *Based on your observations with regard to the table above, what do you conjecture would happen if you extended the table to include other values of  $x$ ?*

After the students had written up their answers to these two questions, the following whole-class discussions ensued.

### Cycle 1: Venturing into Equivalence of Algebraic Expressions - CAS as a Calculating Agent

To initiate the discussion, the teacher posed an open question to the entire class as to what they had observed while filling in the table:

L43. Teacher: So, 1B, "compare the results obtained" (as he reads part of the task question); what results did you obtain? Anyone?

Notice that he started immediately with Q.1B on students' interpretations. His question aimed at uncovering the regularities that the students might have noticed as they filled the table with the values obtained by the CAS substitution operator (Exp |  $x=...$ ). One student responded:

L44. Susan: Expressions 3 and 5 end up having the same answers. So [teacher wrote on the board: #3 = #5].

L45. Teacher: For all of the ones you put in, they ended up having the same answer?



L46. Susan: Yes, and 1 and 4 also.

L47. Teacher: 1 and which one?

L48. Susan: 1 and 4 [teacher wrote on the board: #1 = #4].

We note a particular kind of “notational revoicing” that the teacher has just engaged in: He translated “having the same answers” to the equality #3 = #5. The inference is that, if two algebraic expressions yield the same results when one substitutes a value for  $x$ , then they are equal. Clearly, the equality of two algebraic expressions for certain values of  $x$  does not imply that the expressions are equivalent. The latter requires consideration of the domain - that is, whether the expressions are equal for all, or almost all, real values versus being equal for only some real values of  $x$ . Furthermore, the equivalence of Expressions 3 and 5 is constrained by a restriction.

Up to now, Susan’s observations, with which the rest of the class seemed to agree, had centered on the equality of the numerical results that had been obtained. However, at this particular moment, another student wished to add an idea to the discussion - one that brought the talk from a numerical to an algebraic level:

L49. Ken: The expressions are the same thing as the other ones, just in a different form.

L50. Teacher: So you’re saying that these pairs of expressions (points to #3 = #5 and #1 = #4) are exactly the same?

L51. Ken: Equivalent representations of the same thing.

This interesting comment on the part of the student immediately led the teacher to assume his whole-class-discussion stance: He sat on the corner of an empty desk near the front left-hand side of the class. This suggested that a discussion would ensue - a discussion that could take some time and some thinking. Thus, he sent a signal to the class to listen to and question what was in the process of being discussed. The teacher then invited the student, Ken, to elaborate further:

L52. Teacher: Equivalent representations? Did anybody not get that? So what are we saying? What did you mean by what you said, Ken?

L53. Ken: They represent the same thing, they give you...like if you substitute in  $x$ , like it will come out to the same answer.

L54. Teacher: But why is that the case?

L55. Ken: Because they’re just a different form, like they’re an unfactored form of a, uh, multiplication of two binomials, or something like that.

The student’s difficulties in expressing his mathematical idea in a clear way led to a further question by the teacher, this time directed to the entire class:

L56. Teacher: Does everyone follow what he is saying?

L57. Class: Uh, huh (some students) ... no (other students)

L58. Teacher: No?

L59. Linda: I don’t understand what he is saying.

L60. Teacher: Then stop me. So another way to talk about it, I guess, Ken, would be that they could each be represented in a common form.

Here the teacher (L60) revoiced Ken’s prior response, but then asked the class to explain (L62) what they thought his revoicing meant.

L61. Ken: Yeah

L62. Teacher (to the class): Yes? What do I mean by a common form?

L63. Linda: Simplified?

L64. Teacher: Well, sort of

L65. Linda: Factored

L66. Sara: Expanded ...

The teacher next decided to pull together the last few contributions to the discussion, and in the process added a couple of technical points:

L69a. Teacher: So, in order to be in common form you may have to expand, you may have to factor, you may have to do a combination of the two. You may have to stop half way to get a common form.

**Résumé of Cycle 1.** In this first cycle, the technology played a role in the whole-class discussion, but one behind the scenes - the CAS had permitted the students to rapidly and correctly evaluate the five given algebraic expressions. So, while the CAS was not mentioned explicitly, as agent of calculation it provided the basis for the mathematical discussion that ensued. The content of this cycle focused on the fact that some pairs of expressions, when evaluated numerically, produce the same numerical values. This was linked to algebraic ideas of common form and discourse such as, “equivalent representations of the same thing,” which opened up to the issue of restrictions in the next cycle. The orchestration of the whole-class discussion was highlighted right from the start with the teacher’s inquiring into the students’ thinking regarding the mathematics of the task at hand. He did this by asking for their observations, their elaborations, and their clarifications.

### **Cycle 2: Refining the Concept of Equivalent Expressions to Include Consideration of Restrictions - CAS as a Provoking Agent**

In this cycle, which began immediately after the previous one ended, the teacher wanted to dig more deeply into students’ conjectures as to what would happen if they extended the table to include certain values of  $x$ . The issue was that Expressions 3 and 5 were equivalent under a restricted domain that excluded  $-2$  from the set of admissible values. Even though an open question related to this issue had been posed above in L45, no student had brought forth the idea of restrictions.

L69b. Teacher: Does anyone not agree with these two statements (i.e.,  $\#3 = \#5$ ,  $\#1 = \#4$ ) for any value that they put in? Is it true for all values? [pause] It’s true for all values in both pairs of expressions?

L70. Yannick: It’s the exact same equation [he means *expression*]. If you factor it out, they turn out to be exactly the same.

It was not clear (L70) whether Yannick had, in fact, used the CAS to factor Expressions 3 and 5. If he had, he would have observed - as he had said - the same factored (and simplified) expression for both. However, the CAS would not have alerted him to the issue of a restriction for Expression 5 because the CAS we used (TI-92 Plus) did not display restrictions. Not obtaining any disagreement from the class regarding this issue, the teacher continued with a less open formulation (L75):

L75 Teacher: It would always be the same? So whatever you put in for number 3 will always give you the same as for number 5? [pause] There's no exception to that rule?

L76. Bob: Yeah, there is.

L77. Yannick: It's the exact same equation [i.e., expression]. It's always equal.

L78. Bob: Well I did negative two and it didn't work.

L79. Art: If you put in negative two in the fifth one, then the expression's undefined.

Although Bob and Art had both used the CAS to evaluate for  $x = -2$ , they had not stated why it did not work. This led the teacher to ask them to justify their claims:

L80. Teacher: Why?

L81. Art: Because it will be divide by zero.

L82. Bob: Ok, because it's a restriction.

But the teacher felt that the students had not yet linked this restriction to the issue of the equivalence of the two expressions. Thus, he encouraged further discussion. The voice of the CAS emerged via Matt who had just tried out the following with CAS:

L86. Matt: If you do what Art said [L79], and instead factor number 5, and then put in negative two as a substitute for  $x$ , it will give you the same answer as number 3.

Matt had proposed that they transform Expression 5, by using the CAS factor command, and only then do the substitution of  $x = -2$ . A potential conflict had just arisen here: evaluating at  $x = -2$  before, or after simplifying the given expression, yielded two different answers. In the former case, it produced "undefined" and, in the latter, -84. The numerical output of -84 was the same as that obtained when Expression 3 was evaluated at  $x = -2$ . So the teacher confronted the class:

L89. Teacher: So, which is right and which is wrong?

L90. Yannick: One just isn't formatted properly.

L91. Teacher: What's the answer if you put -2 in?

L92. Matt: Undefined. Well, -84. That's what it should be.

L93. Linda: What?

L94. Teacher: It *should* be? (with an emphasis on *should*).

L95. Matt: When you factor it and you put in negative two it will give you negative eighty-four as the answer.

L96. Teacher: But are you missing something there?

L97. Matt: The restriction.

However, the class did not quite see yet that they should remove -2 from the set of admissible values for Expressions 3 and 5, as was suggested by the conversation that followed. As the discussion continued to unfold, it became clear that this issue was not going to be easily resolved:

L98. Teacher: What is the restriction, what does it mean?

L99. Matt:  $x$  can't equal negative two.

L100. Teacher: What does it mean, why is that a restriction?

L101. Matt: Because you can't divide by zero.

L102. Teacher: So should it be negative eighty-four or should it be undefined?

L103. Matt: Undefined.

L104. Yannick: But if you factor it out?

L105. Teacher: You need to leave the, you need to be aware of that restriction.

The teacher realized that the class was at an impasse with respect to the mathematics at stake and decided to leave aside for the time being the discussion on restrictions. Students were not linking the concept of restrictions with that of equivalence. But, the teacher knew that there would be other tasks coming up that involved new CAS commands and more work on equivalence; thus, he would be able to pursue in a later discussion the relation of restrictions to equivalent expressions.

**Résumé of Cycle 2.** This cycle began with a shift toward the issue of restrictions, which the teacher orchestrated by returning to, and questioning, an assertion made earlier by one of the students. However, the issue deepened when another student shared his CAS explorations with the class - explorations that had allowed him to “remove the restriction” by factoring and simplifying it away. The class was thus faced with a mathematical dilemma: two different evaluations of the same expression, depending on the sequence preceding its evaluation. The teacher’s orchestration included persisting with his initial query, asking students to be more complete in their responses, and even confronting them with the question as to which was right and which was wrong. Eventually, he reminded them that they should not lose sight of the restriction, but realized that they needed more time and additional mathematical activity to adequately think about relating restrictions to equivalence.

## **DISCUSSION AND CONCLUDING REMARKS**

In closing, we revisit the issue of the documented difficulties experienced by teachers (e.g., Sherin, 2002) in generating and maintaining whole-class discussions in literal-symbolic algebra lessons, and the potential of CAS technology to reduce such difficulties. But, first, two caveats. One is a design issue and concerns the tasks. It should be said that the tasks in our study included reflection-type questions that were related to specific output from the CAS and that asked students to think about what these outputs meant. The second touches upon the fit between such tasks and the teacher’s view of how best to bring out the mathematics inherent in them. The teacher in our study considered class discussions to be of crucial importance in this regard.

Even if the mathematics in these tasks involved the letter-symbolic - an area known to be difficult for engaging students in whole-class discussion - the teacher made these discussions work. He employed several strategies, such as:

- phrasing open-ended questions that stimulated, queried as to meaning, asked whether there was disagreement, and sought precision or clarification;
- encouraging student ideas, reflection, and discussion, and signaling the latter by a change in his posture that suggested that they were about to engage in some thinking that could take time;
- revoicing students’ formulation of ideas; and
- elaborating students’ ideas, but only after trying repeatedly to have these elaborations emerge spontaneously from them.

The role that the CAS played was central to the quality of these whole-class discussions in that it was the technology that underpinned both the students' contributions to the discussions and the teacher's inviting of these contributions. As the calculating agent behind the scenes in the first cycle of discussion, the CAS had provided the evaluations that permitted students to talk about their observations and conjectures. As the provoking agent in the second cycle of discussion - an agent whose role had also included being available for students' generating examples and their testing and verifying conjectures - the CAS permitted students to question, within a single discussion, the issues of restrictions, division by zero, and the pseudo-removal of restrictions when an expression is factored and simplified. Even if the questions that had been raised were not all resolved by the end of the discussion, the CAS had clearly played a role not only in adding to the texture of the discussion but also in helping students begin to realize that they had to specify the admissible domain for the equivalence while the expressions were in their original form.

The analysis of the algebra teaching practice that was presented in this paper illustrates how CAS technology can be used as a basis for orchestrating whole-class discussion - discussion that problematizes mathematics with the help of technology.

## Endnote

This research was made possible by grants from the Social Sciences and Humanities Research Council of Canada - INE Grant # 501-2002-0132 and Grant # 417-2007-1485, Ministère des Relations Internationales (Québec), and CONACYT (Mexico) - Grant # U49788-H. We express our appreciation as well to the teacher and his class of students who participated.

## References

- Ball, D. (1993). With an eye on the mathematical horizon: Dilemmas of teaching elementary school mathematics. *Elementary School Journal*, 93, 373-397.
- Boaler, J. (2003). Studying and capturing the complexity of practice: The case of the dance of agency. In N.A. Pateman, B.J. Dougherty, & J.T. Zilliox (Eds.), *Proceedings of the 27<sup>th</sup> Conference of PME* (Vol. 1, pp. 3-16). Honolulu, HI: PME.
- Doerr, H. M. & Zangor, R. (2000). Creating meaning for and with the graphing calculator. *Educational Studies in Mathematics*, 41, 143-163.
- Goos, M., Galbraith, P., Renshaw, P., & Geiger, V. (2003). Perspectives on technology mediated learning in secondary school mathematics classrooms. *Journal of Math. Behavior*, 22, 73-89.
- Hershkowitz, R. & Kieran, C. (2001). Algorithmic and meaningful ways of joining together representatives within the same mathematical activity: An experience with graphing calculators. In M. van Heuvel-Panhuizen (Ed.), *Proceedings 25<sup>th</sup> PME* (V.1, pp. 96-107). Utrecht, The Netherlands.
- Huntley, M. A., et al. (2000). Effects of Standards-based mathematics education: A study of the Core-Plus Mathematics Project Algebra and Functions Strand. *Journal for Research in Mathematics Education*, 31, 328-361.
- Kieran, C. & Drijvers, P., with Boileau, A., Hitt, F., Tanguay, D., Saldanha, L., & Guzmán, J. (2006). The co-emergence of machine techniques, paper-and-pencil techniques, and theoretical reflection: a study of CAS use in secondary school algebra. *International Journal of Computers for Mathematical Learning* 11: 205-263.
- National Council of Teachers of Mathematics. (1989). *Curriculum and Evaluation Standards for School Mathematics*. Reston, VA: Author.
- O'Connor, M. C. (2001). "Can any fraction be turned into a decimal?" A case study of a mathematical group discussion. *Educational Studies in Maths.*, 46(1-3), 143-185.
- Sherin, M. G. (2002). A balancing act: developing a discourse community in a mathematics classroom. *Journal of Mathematics Teacher Education* 5: 205-233.
- Yackel, E. & Cobb, P. (1996). Sociomathematical norms, argumentation, and autonomy in mathematics. *Jour. for Research Maths. Education*, 27, 458-477.

# LESSON STUDY AS A LEARNING ENVIRONMENT FOR MATHEMATICS COACHES

Andrea Knapp

University of Georgia

Megan Bomer

Illinois Central College

Cynthia Moore

Illinois State University

*This qualitative study focused on the development of one graduate mathematics coach as he engaged in the lesson study process over the course of two school years. The coach developed mathematical knowledge for teaching in three ways. First, he developed knowledge of content and teaching by entering into cognitive dissonance with a teacher and collaborating with him to place a stronger emphasis on inquiry in lessons. In addition, the coach developed knowledge of content and students as he listened to students and observed them on videotape. Finally, he developed specialized content knowledge by considering mathematical representations for the lesson.*

## BACKGROUND AND RELATED LITERATURE

The field of professional development coaching currently enjoys steady growth in mathematics education as schools are searching for effective ways to support the learning of in-service teachers (Stigler & Hiebert, 1999). Although coaching is gaining popularity as a means of professional development, its forms of implementation vary (Olson & Barrett, 2004). In addition, most research on coaching focuses on effects on the professional development of teachers rather than on the development of coaches themselves (Thompson et al., 2003).

The National Science Foundation (NSF) has established a program that provides coaches for schools called Graduate Fellows in K-12 Education (GK-12). The purpose of this study was to examine the professional development of coaches, or Graduate Fellows, within the context of GK-12. Nationwide, the GK-12 program awards grants to universities to place graduate students from disciplines of science, technology, engineering, and mathematics (STEM) into K-12 classrooms for the purpose of jointly designing and delivering K-12 science and mathematics instruction with classroom teachers. Consequently, the GK-12 program integrates research and teaching through a professional development model (Moore, 2003) which is a form of *collaborative coaching* (Olson & Barrett, 2004). Graduate Fellows receive training in constructivism and standards-based pedagogy. The purpose of this study was to examine the professional development of the Fellows as they engaged in lesson study.

Lesson study has captured the attention of professional developers in the United States as they attempt to provide learning environments for teachers which impact student understanding (Stigler & Hiebert, 1999). Originating in Japan, lesson study involves a cyclical process of researching, developing or adapting, teaching and observing, revising, and repeating lessons. In Japan, lesson study has steadily and positively impacted teachers to change from teacher-directed to student-directed instruction

(Takahashi and Yoshida, 2004). Lesson study in the United States has spread rapidly and taken numerous forms as schools seek to capture its essential elements in their particular contexts (Fernandez, 2005; Lewis, Perry, & Murata, 2006).

As various educational stakeholders have implemented lesson study, promising yet limited results regarding teacher development have emerged. For example, Fernandez (2005) found lesson study to provide elementary teachers opportunities to develop new pedagogical content knowledge, to learn how to reason mathematically, and to motivate them learn more mathematics. Presmeg and Barrett (2003) likewise found that lesson study encouraged teachers to anticipate students' reasoning and strategies related to mathematical concepts. Finally, Pothen, & Murata (2007) found lesson study to support the development and transformation of teachers' content knowledge, pedagogical knowledge, and pedagogical content knowledge.

Given our emerging knowledge about the benefits of lesson study for professional development, we decided to employ lesson study in the professional development of the GK-12 coaches at Mid Western University (pseudonym). Thus, we ask:

In what ways do collaborative coaches of mathematics develop mathematical knowledge for teaching as they engage in lesson study?

## **THEORETICAL FRAMEWORK**

Cobb and Yackel (2004) described the emergent perspective as version of social constructivism which coordinated interactionism and psychological constructivism. This perspective came from finding neither the social aspects of learning nor the individual psychological aspects to be elevated above the other but rather to be "reflexively related such that neither exists independently of the other" (p. 212). The emergent perspective appeared especially suited to this study because the construct of mathematical knowledge for teaching (MKT), on which our analysis is based, is inextricably related to the construct of classroom social norms as outlined in the emergent perspective (Hill, Rowan, & Ball, 2005; Cobb and Yackel, 2004). Thus, we chose the emergent perspective to study development of MKT.

We chose to analyse our data using the theory of mathematical knowledge for teaching (MKT) because of its link to student achievement. The seminal study relating teacher knowledge to student achievement found that MKT was a key to predicting student gains in first and third grade (Hill et al., 2005). MKT is categorized in six parts (See Table 1). Common content knowledge (CCK) is basic, lay-person knowledge of the mathematical content. Specialized content knowledge (SCK) is the way the mathematics arises in classrooms, such as for building representations. Knowledge of content and students (KCS) is knowing how students think about mathematics. Knowledge of content and teaching (KCT) involves knowing the most effective examples or teaching sequences. We understand Shulman's (1987) definition of pedagogical content knowledge to be a marriage of KCS with KCT. Knowledge of curriculum and knowledge at the mathematical horizon are the final components of mathematical knowledge for teaching. In this study, we focused on SCK, KCS, and KCT.

Subject Matter Knowledge	Pedagogical Content Knowledge
Common Content Knowledge (CCK)	Knowledge of Content and Students (KCS)
Specialized Content Knowledge (SCK)	Knowledge of Content and Teaching (KCT)
Knowledge at the Mathematical Horizon	Knowledge of Curriculum

Table 1. Mathematical Knowledge for Teaching

## METHODS OF DATA COLLECTION AND ANALYSIS

We chose to employ qualitative, multi-tiered teacher development experiment (TDE) methodology because the goal of a TDE is to generate models for teachers' mathematical and pedagogical development, closely matching our research aims for the collaborative coaches (Lesh & Kelly, 2000; Presmeg & Barrett, 2003). Although 11 Fellows in the GK-12 program at Mid Western University participated in the first year lesson study and 4 Fellows participated in the second year, we focus on one Fellow, Dave (pseudonym), who participated both years. For data collection for the case study, the research lessons were video-taped. In addition, the authors wrote field notes and Graduate Fellows wrote selected reflections about the video taped lessons. During the second year, pre and post planning sessions were audio-taped and transcribed. Dave was interviewed before and after the second year lesson study as well. Finally, lesson plans and student work from the second year were collected.

Qualitative data analysis focused on identifying portions of transcripts providing evidence for the development of and the opportunity to develop the elements of mathematical knowledge for teaching (MKT) (See Table 1). To establish inter-rater reliability, the first two authors independently coded data for CCK, SCK, KCS, and KCT. As these elements of MKT were identified, we noted the ways in which those particular elements developed.

## RESULTS AND DISCUSSION

In this section, we describe the lesson study focus for each year and the ways in which one collaborative coach, Dave, developed MKT during both years. Representative quotes provide evidence for each type of knowledge development (ie. SCK, KCS, KCT). We additionally demonstrate how we interpreted the *ways* in which he developed MKT.

For the first year, the topic chosen for the lesson study was interpreting graphs. The coaches and teachers used Calculator Based Rangers (CBR's) to have students graph their motion on graphing calculators as a way of introducing graphical interpretation. CBR's are motion detectors which allow students to see graphs of their own motion created in real-time. After presenting the lesson, Dave wrote in his reflection,

I wish that I would have given more clear directions at the start. I felt that I left a few details out, but I think the students did a great job!



Dave's reflection indicated that although he had left out details he had hoped to address, he was pleased with the student learning in the lesson. However, he did not discuss any specific ways to go about making any changes to the lesson. After Dave presented this lesson, the group of Fellows viewed the video tape from the lesson and discussed revisions to the lesson. The second author noted,

We watched the video, and a lot of the discussion was about the intro. People felt like the intro was maybe too long, the students weren't involved enough, and that it went too in depth (i.e. some of the things Dave explained in the intro could be left for students to first discover on their own when they were experimenting and then discuss after).

Although Dave had identified in his reflection that his introduction was lacking in clarity, the lesson study revision process revealed that greater changes to the introduction would benefit students and suggested specific ways to make these changes. The group decided that students should be allowed to discover concepts instead of Dave telling them about concepts in the beginning of the lesson. In a follow-up interview, Dave confirmed that he had learned from the collaboration process by stating that at first, he thought that explaining distance versus time graphs up front would help students have their "Aha!" moment about how the graphs were formed. He later concluded that students learned more quickly if they were allowed to make discoveries on their own. Thus, the lesson study process and collaboration with other Fellows encouraged Dave to develop both knowledge of content and students (**KCS**) and knowledge of content and teaching (**KCT**). KCS developed as Dave realized that students grasp concepts when they construct their own knowledge. KCT developed when other Fellows and Dave identified deficiencies in the lesson, and they agreed upon changes that supported student learning. The reflection and revision process of lesson study allowed Fellows to critique their lesson with respect to standards- and inquiry-based instruction. Cognitive dissonance, or dissatisfaction with the enactment of the lesson with respect to beliefs about teaching, when experienced within lesson study environment, allowed Fellows to make their implicit beliefs about teaching explicit through discussion and reflection (Olson, Colasanti, & Trujillo, 2006). Fellows could then purposefully plan to align their teaching practices with their emerging beliefs about the benefits of inquiry-based instruction, and thereby improve their KCT.

During the second year of the study, the lesson study group met six times to plan the research lesson. To help identify a lesson study topic, the teacher took an informal poll of teachers in his department about common student misconceptions and areas of difficulty. During the planning meeting he said,

Teacher: I was telling Tom [a Fellow] I kind of did a survey of thoughts of what people struggled with in terms of teaching slope intercept form. I got a bunch of different answers, some of them were the same so I didn't really repeat

Dave: Right, yeah.

Teacher: But I got some people that, you know, their biggest task is alright teaching that the y intercept is an ordered pair. It's a physical spot on the graph. Where you

know, when you get your  $y=mx+b$  well  $b$  is a number but then how does it translate to a physical spot on the graph. Well, we're mathematicians, we know by now because we've been drilled it's on the  $y$  axis, but how many kids put it on the  $x$  axis?

As Dave listened to the teacher describe student difficulties, he developed knowledge of content and students (**KCS**) by tapping into the teacher's knowledge of students. Furthermore, he recounted his own experience with teaching slope.

Dave: I'm trying to think, I remember like, seems like when I would teach each individual part they would seem like they got it. But then when you put it all together, then they were like whoosh.

Thus, as Dave listened to the teaching problems and issues of teachers and other Graduate Fellows, he entered into the space of cognitive dissonance, motivating him to seek ways to improve the teaching of the concepts which had been discussed. Lesson study provided a safe environment for both the teacher and Dave to be vulnerable about their mathematical knowledge for teaching, and thus work collaboratively to support each other's learning. After discussing the content and teaching issues with the teacher, Dave would often look to research, seek out University mathematics educators, or peruse reform-based curricula for learning tasks which would inform an improved lesson, thus further developing his knowledge of content and teaching (**KCT**). Dave had an opportunity to immediately transfer theory to practice as he implemented agreed upon reform-based interventions and supporting technologies. Thus the lesson study environment facilitated fertile ground for the coach's beliefs and practices to change.

After choosing the lesson study topic, the group discussed the best representation for introducing slope.

Teacher: You can give them all right cheese pizza \$5 at Papa John's and then it's \$2 per topping. What's the cost of the pizza. You can show them, you don't buy a pizza you don't have to pay anything, so or now if you don't get any toppings it's still \$5 and each, work your way up show them. Now they don't get the concept of if there's an infinite set of points between those two, well how do I buy or put on 2.4 toppings, well you don't. So theoretically we got to get away from that, in terms of all the infinite set of points. But at least with a discrete value to get started so that they can get some concept of rise and run.

Fellow #2: I'm, that's a great way to show, count one over two over. Inside of a discrete model works out well for stuff like that.

Dave: It seems like time and money works well for the...model whether it's, you know, plumber charges so much per hour, or you know, cost per minute.

Teacher: Most of them understand money cause they have to buy things already.

As the lesson study group discussed how to present slope, the mathematical concepts of discrete and continuous variables entered the conversation, prompting the participants to consider contexts for explaining slope. Specialized content knowledge (**SCK**) developed as they considered discrete contexts. In addition, knowledge of content and teaching (**KCT**) developed as they considered which discrete context

students would most likely understand. Thus, lesson study allowed Dave to develop KCS, KCT, and SCK.

In summary, this study highlighted several ways in which lesson study may support the development of mathematical knowledge for teaching in collaborative coaches. First, knowledge of content and teaching (KCT) develops as coaches revise and reteach lessons. Second, KCT develops during the planning phase as coaches consider what contexts students will connect with. Third, knowledge of content and students (KCS) develops as teachers share with coaches the areas in which they anticipate student difficulty. Lesson study prompts coaches to enter into cognitive dissonance with teachers, motivating the coaches to seek out ways to address student learning. KCS also develops as coaches observe students during the research lessons. Finally, specialized content knowledge develops as mathematical topics surface during the planning and reflecting phases. In conclusion, lesson study improves coaches' mathematical knowledge for teaching by providing a learning environment in which coaches can ground their pedagogical and mathematical learning in the context of the teachers which they support.

### Endnote

This study was supported by NSF grant: DGE-0338188.

### References

- Hill, H. C., Rowan, B., & Ball, D. L. (2005). Effects of teachers' mathematical knowledge for teaching on student achievement. *American Education Research Journal*, 42 (2), 371-406.
- Cobb, P. & Yackel, E. (2004). Constructivist, emergent, and sociocultural perspectives in the context of developmental research. In T. Carpenter, J. Dossey, & J. Koehler (Eds.), *Classics in Mathematics Education Research* (pp. 208-226). Reston, VA: NCTM.
- Fernandez, C. (2005). Lesson study: A means for elementary teachers to develop the knowledge of mathematics needed for reform minded teaching? *Mathematical Thinking and Learning*, 7(4), 265-289.
- Lesh, R. & Kelly, A. (2000). Multitiered teaching experiments. In A. Kelly & R. Lesh (Eds.), *Handbook of Research Design in Mathematics and Science Education* (pp.197-230). Mahwah, New Jersey: Lawrence Erlbaum Associates.
- Lewis, C., Perry, R., & Murata, A. (2006). What is the role of the researcher in an emerging innovation: The case of lesson study. *Educational Researcher*, 35(3), 3-14.
- Moore, C. J. (2003). Partnership for Research in Science and Mathematics Education mission statement. United States: Illinois State University, Biology Department.
- Olson, J. & Barrett, J. (2004). Coaching teachers to implement mathematics reform recommendations. *Mathematics Teacher Education and Development*. 6, 63-78.
- Olson, J. Colasanti, M., & Trujillo, K. (2006). Prompting growth for prospective teachers using cognitive dissonance. In J. Novotna, H. Moraova, M. Kratka, & N. Stehlikova (Eds.) *Proceeding 30<sup>th</sup> Conference of the Inerantional Group for the Psychology of Mathematics Education* (Vol. 4, pp. 281-288). Prague, Czech: Charles University.

- Pothen, B.E. & Murata, A. (2007). Transforming teachers' knowledge: The role of lesson study in preservice education. In T. Lamberg & L. R. Wiest (Eds.), *Proceeding 29<sup>th</sup> Conference of the North American Chapter of the International Group for the Psychology of Mathematics Education* (pp. 999-1006). Stateline (Lake Tahoe), NV: University of Nevada, Reno.
- Presmeg, N. & Barrett, J. (2003). Lesson study characterized as a multi-tiered teaching experiment. In N. Pateman, B. Dougherty, & J. Zilliox (Eds.), *Proceeding 27<sup>th</sup> Conference of the International Group for the Psychology of Mathematics Education* (Vol. 4, pp. 47-54). Honolulu, USA: PME.
- Shulman, L.S. (1987). Knowledge and teaching: Foundations of the new reform. *Harvard Education Review*, 57(1), 1-22.
- Stigler, J. & Hiebert, J. (1999). *The Teaching Gap: Best Ideas from the World's Teachers for Improving Education in the Classroom*. New York: The Free Press/Simon and Schuster.
- Takahashi, A. & Yoshida, M. (2004). Ideas for establishing lesson-study communities. *Teaching Children Mathematics*, 10(9), 436-443.
- Thompson, S., Metzgar, V., Collins, A., Joeston, M., & Shepard, V. (2003). Examining The Influence of A Graduate Teaching Fellows Program on Teachers in Grades 7-12. *Journal of Geoscience Education* V5 1 no 1. Available at [http://www.ed.psu.edu/CI/Journals/2002aets/t2~thompson\\_metzgar\\_c.rt](http://www.ed.psu.edu/CI/Journals/2002aets/t2~thompson_metzgar_c.rt)



# **FOSTERING INSTRUCTIONAL CHANGE THROUGH MATHEMATICS PROFESSIONAL DEVELOPMENT: FOCUSING ON TEACHERS' SELF-SELECTED GOALS**

Karen Koellner

University of Colorado Denver

Jennifer Jacobs

University of Colorado Boulder

*As part of the Problem-Solving Cycle (PSC) model of mathematics professional development, teachers identify and pursue self-selected pedagogical goals. In this paper, we closely examine the goals of one teacher who participated in this PD model and her attempts to use more challenging pedagogical strategies. We describe the evolution of her self-selected goals based on written descriptions, videotaped conversations during the PD workshops, and videotaped interviews. We also provide a quantitative analysis of how her goals played out in her classroom over the course of one academic year. This case study demonstrates the potential of the PSC model, and a focus on self-selected goals, to motivate pedagogical experimentation.*

## **BACKGROUND AND THEORETICAL FRAMEWORK**

Enhancing students' learning opportunities often times depends fundamentally on the knowledge and skills of teachers (Darling-Hammond, 1996; Spillane, 1999). At the same time, however, there is substantial evidence that many teachers do not have the knowledge of content and pedagogy needed to meet the ambitious goals for student learning set by educational reform movements. Achieving these goals will require a great deal of learning on the part of teachers. This realization has led educational scholars and policymakers to focus their attention on the importance of professional development (PD) opportunities for teachers—opportunities that will help teachers to enhance their professional knowledge and develop new instructional practices (Ball and Cohen, 1999; Borko, 2004; Wilson & Berne, 1999). Although high quality PD is currently in great demand, the field is at a very early stage. Numerous PD programs have been developed, but few have been implemented on a large scale or researched, particularly with respect to their impact on teacher knowledge and practices and student achievement (Borko, 2004). However, researchers are beginning to document effective and ineffective characteristics of PD models (Garet et al., 2001; Hargreaves, 1995). Many characteristics found to be effective are aligned with situative theories of learning.

Situative perspectives on cognition and learning provide the conceptual framework that guided the design of our PD program. Scholars within a situative perspective argue that knowing and learning are constructed through participation in the discourse and practices of a community and are shaped by the physical and social contexts in which they occur (Greeno, 2003; Lave & Wenger, 1991). One facet of the situative theories is that cognition is distributed and not stored solely in one individual or one learning tool. This idea implies that interacting within a diverse community of colleagues, each with their own experiences and insights, is a critical

component in helping teachers to become more reflective and to grow as professionals. In addition, situative theorists suggest that because learning takes place within a particular context, "authentic activities" that reflect this context are critical. For teachers, their own classroom events are powerful contexts.

Three principles derived from a situative framework are central to the design of our PD model described in this paper: creating a professional learning community, using video from teachers' own classrooms to provide a meaningful context for learning, and establishing community around video. In addition, an important element in our PD model is explicit attention to teachers' individual pedagogical goals.

### **The Problem-Solving Cycle Model of Professional Development**

We recently designed, implemented, and conducted an initial program of research on our the Problem-Solving Cycle (PSC) model of mathematics professional development as part of the Supporting the Transition from Arithmetic to Algebraic Reasoning (STAAR) project (Koellner et al., 2007). The PSC model is an iterative, long-term approach to PD, with the goals of increasing teachers' knowledge of mathematics for teaching, improving their instructional practices, and fostering student achievement gains. One iteration of the PSC consists of three interconnected workshops in which teachers engage in a common mathematical and pedagogical experience, organized around a rich mathematical task. During these three workshops, the teachers solve the selected task, implement it in their classrooms (and are videotaped), and consider specific aspects of their instructional practices and their students' mathematical thinking.

The PSC model capitalizes on the power of video to situate PD activities in teachers' instructional practices and to help teachers deeply investigate issues around teaching and learning a specific mathematics problem. Participating in the PSC provides teachers with the opportunity to work together in a professional community, share their knowledge, and support one another. Successive iterations build on one another and capitalize on the group's expanding knowledge of mathematics for teaching and developing a sense of community. Another central component of the PSC involves having teachers generate individual goals for improving their classroom mathematics instruction. This process of generating goals serves multiple purposes. It enables the facilitators to gauge the instructional issues the group finds essential and interesting and then to later frame the workshops accordingly. Individual goals (which can be continually revised) also provide each teacher with a unique lens through which they can plan and critique their videotaped lessons. By generating and acting on self-selected goals, teachers determine their own starting point for reform and to work towards instructional change in areas that are personally relevant for them within the structure of our professional development design.

### **METHOD**

In this paper we focus on one participant in the STAAR professional development program, Celia Hall, and closely examine the goals she identified and pursued

throughout the course of one school year. We elected to follow one single teacher, rather than the full group of seven teachers, so that we could look in depth at how her goals were refined over an entire year and the effect her goals had on her practice. With 14 years of teaching experience in fifth and sixth grades, Celia was among the most experienced teachers in the group and had some of the most clearly articulated goals and intentions. We expected that Celia would most likely be highly reflective and would strive to make changes in her instructional practice.

We held seven, full-day PD workshops over the course of one school year. We also conducted regular videotaped observations of each teacher's classrooms. Each of the PD workshops were videotaped with several cameras in order to capture whole and small group conversations. In addition, teachers' classrooms were videotaped using two cameras--one that followed the teacher and another that focused on a small group of students.

Our two central research questions are:

- 1) In what ways did Celia's goals change over time?
- 2) Did Celia change her classroom practices in ways that reflected her goals?

In order to document Celia's self-selected pedagogical goals and consider the ways these changed over time, we relied on three data sources: written descriptions of her goals created during the monthly PD workshops, videotapes of the workshops (including small group conversations related to Celia's goals), and semi-structured interviews with Celia after each of her classroom observations (portions of which focused explicitly on her goals). These data sources were used to help us understand not only Celia's evolving goals but her instructional intentions and related explanations as well. For each workshop, we wrote a detailed summary based on Celia's written descriptions of her goals (including any revisions and explanations) and any videotaped conversations that she had about her goals. We then merged these summaries with excerpts from written transcripts of Celia's six interviews that related to her goals. We considered the data in chronological order and were ultimately able to characterize her goals as falling into four distinct stages.

In order to consider how Celia's classroom practices changed, we coded videotaped lessons that were collected at six time points throughout the year (October, December, January, February, April, and May). The class that Celia selected to be videotaped was her sixth grade mathematics class, which she describes as "low track" students. We watched Celia's lessons informally and then developed codes that related to her goals. For some of the codes, we relied on video from the "teacher-focused" camera and for other codes we used video from the small-group "student-focused" camera. We wrote detailed coding definitions and established inter-rater agreement of at least 80% for each code. We discussed each discrepancy until we reached agreement. We then independently coded the remaining lessons, occasionally conferring on portions of the video in which we were uncertain. Further descriptions of the relevant codes are provided in the results section.



## RESULTS

### Evolution and Enactment of Celia's Goals

#### *Stage 1: Improving Group Dynamics*

Celia's initial goal focused on improving group dynamics in her classroom. Specifically, she wanted to encourage her students to talk more and share their ideas with one another during group work. Previously up to this point in her career, Celia had not often emphasized group work. However, based on her own positive experiences learning mathematics content through extended periods of group work in the a two-week algebra course that was part of the STAAR summer course project, Celia was determined to experiment with this strategy in her classroom.

In the interview after her first videotaped lesson, Celia remarked, "One thing that I learned very much from the summer class was...you don't have to have independent [student work] time...They learn so much from each other and I learned so much from my peers this summer." She noted that it can be hard as a teacher to get around to all students in the classroom, but if they work together, another student in the group can help redirect someone who is struggling or is off-base.

Celia said she was very conscious of how she assigned her students to groups. Convinced that heterogeneous groups of four would be the most beneficial, she created groups by putting together her stronger and weaker students. At the same time, Celia changed groups frequently (i.e., every few weeks) so that her students would become comfortable working with all of their peers. In particular she wanted students to experience working with peers they had never worked with before and with members of the opposite sex. Another strategy Celia used for collaboration was to only give each group (of four students) one or two handouts with the assigned problem(s). Celia explained that by not giving students individual handouts, "they would have to share and...talk to each other. And they have to read along with the other person to be able to get the work done."

#### *Enactment Stage 1: Improving Group Dynamics*

Changes were observed in Celia's six videotaped lessons. Celia reported that she thought carefully about how to put students in groups, specifically deciding to put together stronger and weaker students and changing them frequently so they would get used to working with many of their peers. After the coding analysis, we analyzed the percentage of class time that Celia's students worked in small groups during each of her lessons. During lesson one, 38% of class time was used for group work as compared to lesson five where 73% of class time was used for small groups. Given Celia's report that she previously almost never used groupwork, these relatively high percentages indicate that she is now committed to devoting more than a third of her lesson time on any given day to groupwork.

#### *Stage 2: Encouraging More Student Talk*

Whereas Celia began the school year concerned that her students might become too noisy if they worked in groups, she soon said she felt comfortable with this approach and wanted to concentrate more on helping them to express themselves verbally. Therefore, during the second PD workshop, Celia broadened her goal to focus on encouraging more student conversations in small groups and during whole class interactions. To foster more student talk within small groups, Celia decided to discuss norms and expectations for group work with her students. Together the class developed a list of “rules for group work” which Celia posted on a wall in the classroom. In addition, because Celia always seated students in groups of four, she designated four roles including reader, recorder, facilitator, and work checker.

To help her students talk more during whole class interactions, Celia began having groups present their ideas and solution strategies to the rest of the class. She found that students enjoyed using the overhead and sharing their work. In order to ensure that these presentations would be productive, Celia discussed the process in some detail with her students, highlighting the importance of listening carefully to other students. In an interview she noted, “We’ve talked about the norms for what everybody else will be doing when one person’s up there--that you give them, you know, credence, and you give them your attention and you’re not off doing something else.” Celia also explained that she has shifted from having one representative from the group (the “speaker”) share their ideas to having the entire group present. She said, “It really worked better I think, because they had solved it as a group. Then they could help each other.”

### *Enactment of Stage 2: Encouraging More Student Talk*

Celia said she was diligent about frequently reminding her students to work together or explain their ideas to one another. We looked at each of her videotaped lessons in four minute intervals and marked how many of those intervals contained encouraging remarks made by Celia encouraging her students to work together. For example, she commented “make sure everyone in your group understands” or “share that idea with the rest of your group.” We found that Celia did not make any such remarks in her first lesson but then made them approximately 30% of the time in the second lesson, almost 40% of the time in the third lesson, close to 50% of the time in lessons 4 and 5, and then only about 10% of the time in lesson 6. One possible explanation of this decrease in the sixth lesson is that her students may not have needed as many reminders by the end of the year.

### *Stage 3: Asking Deeper Questions of Students*

Still conscious of having students work well in groups and talk to one another throughout the lesson, during the third PD workshop, Celia generated the additional goal of asking deeper questions to her students. She wanted to shift from mostly confirming whether students’ answers were correct to probing students more about their thinking and having them justify their answers. Celia talked about this goal in an interview, saying, “You know, my first inclination is to say, when they have it

right, ‘Oh great. Good job.’ [And] move on. And so that’s what I’m working on is [asking,] ‘Well how do you know that that’s right?... Are you sure it’s right?’”

Celia remarked that when she first shifted to using these questioning strategies, her students became nervous and immediately thought she assumed they were wrong. However, Celia reported that they grew increasingly adept in verbalizing their thinking and offering mathematical explanations. When her students appeared to be having trouble with the mathematics, Celia’s objective was to ask questions that would help them move forward. However, she often found this goal particularly challenging, stating, “It’s hard for me to come up with a question that’s going to get them there...I think it’s better, but I have to work on it.”

### *Enactment Stage 3: Asking Deeper Questions of Students*

In stage 3, Celia focused more on her questioning strategies and what she could say to her students to probe their thinking. In our video analysis, we considered how Celia talked to her students during group work, analyzing the conversations at 4-minute increments. For each increment, we coded whether Celia told her students they were right or wrong without first asking them to explain, justify, or reason. For this latter category, the students had to make some sort of response to Celia’s probe in order for it to count as prompted reasoning.

We found some variation from lesson to lesson, but overall Celia did seem to work on reducing her tendency to tell students whether they were right or wrong and increasing her efforts to prompt students to reason. That being said, Celia did a fair amount of telling students whether they were right or wrong without asking for reasoning in her first four lessons. Specifically, in lessons 1 and 4, she spent 20% of her time telling students whether they were right or wrong, 27% of the time in lesson 2, and 90% of the time in lesson 3. In lessons 5 and 6, we did not find any instances of telling students whether they were right or wrong. As for prompting students to explain, justify, or reason, although Celia never did this during her first lesson, she did so quite often in the rest of her lessons. In particular, in lessons 3, 5 and 6, she probed for explanations, justifications, and/or reasoning over half the time she worked with students during group work.

### *Stage 4: Having Students Ask Deeper Questions of One Another*

At the end of the school year, Celia noted that her future goal would include helping students to become better questioners and ask deeper questions of one another. Particularly during group work, Celia wanted her students to push each other more to share and verbalize their thinking. Specific examples of these types of questions include, “How did you get that?” and “Can you explain that to me?” As Celia told us, “I know that I still have a long, long way to go. I have made progress this year, and I’m going to continue working on my goals.”

## **Discussion and Implications**

The STAAR professional development, and the PSC in particular, provided opportunities for teachers to frequently revisit their goals. We asked them to write

about their goals, discuss them with their colleagues, view videotapes (individually and collaboratively) with their goals in mind, and talk about their goals with the research team immediately following each videotaped classroom observation. This structure provided an avenue for teachers to reflect on many different occasions at different levels (including during workshops and outside of workshops).

We did not always find a linear progression on Celia's goals throughout the year. It is possible that some lessons lent themselves to advancing particular goals, while others did not. In addition, we coded only six of Celia's lessons, and we know from her interviews that she sometimes experimented with new ideas on days we did not videotape. Also, it is challenging to capture in a single code (or set of codes) what Celia was trying to do with respect to her goal and the degree in which she succeeded in a given lesson. However, it is clear that Celia was continually mindful of her instructional practices, constantly monitoring her own progress informally and challenging herself by revising her goals. The opportunities provided by the PD experience, combined with Celia's strong internal drive, led her to experiment with a wide range of pedagogical innovations.

Classroom change is a unique process for all teachers and developing individual goals may be a strong factor in promoting self-reflection and motivation for improvement. Intentionally designing PD to include teachers' self assessment of their classroom practice and targeting areas for improvement appears to be a topic worthy of more intensive investigation. In our PD model, we ask teachers to reflect on their teaching, self-identify goals for improvement, and generate ideas for meeting those goals. As we have described in this paper, the PSC model encourages a supportive learning community that places a strong emphasis on watching and discussing video from the teachers' own lessons. Our case study of Celia demonstrates the potential of this model to motivate pedagogical experimentation. Whether these changes foster student learning is clearly a topic that is in need of further research. The opportunity to address teachers' own practices and to strive to improve on self-identified goals holds promise as a PD design if developed in conjunction with the other standards for professional development including collaboration, analysis of practice, and multiple levels of critical reflection.

## References

- Ball, D. L. & Cohen, D. K. (1999). Developing practice, developing practitioners: Toward a practice-based theory of professional education. In L. Darling-Hammond & G. Sykes (Eds.), *Teaching as the Learning Profession: Handbook of Policy and Practice* (pp. 3-32). San Francisco: Jossey-Bass.
- Borko, H. (2004). Professional development and teacher learning: Mapping the terrain. *Educational Researcher*, 33(8), 3-15.
- Garet, M.S., Porter, A.C., Desimone, L., Birman, B., & Yoon, K.S. (2001). What makes professional development effective? Results from a national sample of teachers. *American Educational Research Journal*, 38(4), 915-945.

- Greeno, J. G. (2003). Situative research relevant to standards for school mathematics. In J. Kilpatrick, W. G. Martin, & D. Schifter (Eds.), *A Research Companion to Principles and Standards for School Mathematics* (pp. 304-332). Reston, VA: National Council of Teachers of Mathematics.
- Koellner, K., Jacobs, J., Borko, H., Schneider, C., Pittman, M., Eiteljorg, E., Bunning, K., & Frykholm, J. (2007). The Problem-Solving Cycle: A model to support the development of teachers' professional knowledge. *Mathematical Thinking and Learning*, 9(3), 271-303.
- Wilson, S. M. & Berne, J. (1999). Teacher learning and the acquisition of professional knowledge: An examination of research on contemporary professional development. In A. Iran-Nejad & P.D. Pearson (Eds.), *Review of Research in Education* (Vol. 24, pp. 173-209).

# ON CONSIDERATIONS OF PARSIMONY IN MATHEMATICAL PROBLEM SOLVING

Boris Koichu

Technion - Israel Institute of Technology

*In this theoretical essay I suggest that considerations of intellectual parsimony, in general, and balancing between different kinds of parsimony, in particular, is a mechanism explaining many well-documented phenomena in mathematical problem-solving. This suggestion is supported by re-analysis of data taken from three recently published research papers. Further, an attempt to incorporate the considerations of parsimony in selected theoretical models of problem solving is undertaken; some implications are drawn.*

## INTRODUCTION

Problem solving attracts keen attention of mathematics education research community for more than 60 years (cf. Lester, 1994; Cai, Mamona-Downs & Weber, 2005). As a result, many empirical models aimed at capturing the complexity of problem solving have been produced. For instance, some scholars described problem solving in terms of external and internal representations (e.g., Goldin, 1998). Others distinguished particular problem-solving phases, cycles, patterns and attributes (e.g., Carlson & Bloom, 2005; Koichu, Berman, & Moore, 2006; Schoenfeld, 1985; Verschaffel, 1999). As a result, major progress has been achieved regarding the question of how mathematical problem solving can be described and characterized (Cai, Mamona-Downs & Weber, 2005). As can be expected, current and future research would concern cognitive mechanisms that seem to govern the observed problem solving behaviours (cf. Harel, 2006; in press).

One of such mechanisms is in the focus of this essay - that of considerations of intellectual parsimony, in general, and balancing between different kinds of parsimony, in particular, when solving a mathematical problem. The purpose of this paper is to support the claim that this ubiquitous cognitive process is responsible for several well-documented phenomena in mathematical problem solving.

In the next section I briefly discuss an ontological formulation of the principle of parsimony and construct its epistemological analogue. This is followed by discussion of three recently published studies, in which, I believe, considerations of parsimony strongly manifest themselves throughout the findings presented. The essay is concluded with an attempt to find a place for the principle of parsimony in selected models of mathematical problem solving and to outline some of its implications.

## THE PRINCIPLE OF PARSIMONY

The concept of *parsimony* frequently appears in papers about aesthetical aspects of mathematical thoughts (e.g., Dreyfus & Eisenberg, 1986; Krutetskii, 1976; Sinclair,

2004). It is usually used there as a counterpart of *elegancy* or *simplicity*. In addition, the adjective *parsimonious* appears in papers containing critical discussions of broad theoretical perspectives, like constructivism, information-processing theory or theory of representations (e.g. Goldin, 2000; Orton, 1995; Rowlands, 2001). In the former papers, *parsimony* serves as a cognitive characteristic of mathematical problem solving of particularly gifted individuals. In the latter papers, it is argued that some theoretical perspectives are more *parsimonious* than others with respect to their underlying assumptions, and thus, are more viable or general. All these uses of the term *parsimony* bear explicit or implicit connotations to the *principle of parsimony* also known as Ockham's razor.

The ontological form of Ockham's razor postulates: *when constructing a theory, one should not make more assumptions than the minimum needed*, or, in other words, *one should make additional assumptions only when forced to do so by the evidence, which cannot be satisfactorily explained with less assumptions* (cf. Baker, 2004; Sober, 1979). This methodological maxim is taken for granted as a basic principle of developing natural sciences and mathematics (e.g. Menger, 1960).

Koichu & Berman (2005) suggest a paraphrase of Ockham's razor that takes it to the epistemological grounds: *when achieving a goal, for instance, when solving a problem, one intends not to make more intellectual effort than the minimum needed*. In other words, *one makes more effort only when forced to do so by the evidence that the problem cannot be solved with less effort*.

The classic, ontological, formulation of the principle of parsimony is frequently found useful yet too vague (e.g. Foster, 2000). Definitely, it evokes various interpretations, implications and disputes (see Baker, 2004; Sober, 1979). Undoubtedly, the same holds for the paraphrase of the principle. It should be elaborated and illustrated, which, in part, is done in the next section.

### THREE EXAMPLES

The examples presented here are chosen from a broad collection of problem solving phenomena that can be explained using the principle(s) of parsimony. The examples represent different mathematical contexts and different research settings, and hereby implicitly point to the ubiquitousness of considerations of parsimony in mathematical problem solving.

#### **Example 1: Should a mathematical definition be minimal?**

In their study on students' conceptions of a mathematical definition, Zaslavsky and Shir (2005) created a research situation in which a group of high school students was given a list of statements defining a well-known mathematical concept, and asked to collectively decide which statements may be accepted as definitions of the concept and which ones may not. In particular, the students discussed the following definition of a square: *a square is a quadrilateral in which all sides are equal and all angles are 90°*. The following dialogue concerning this (non-minimal) definition is presented in the paper (p. 329):

Erez: It is correct, but it is not a definition.

Yoav: It is correct, and it is a definition.

Erez: It has too many details.

Yoav: Too many details, but it is still a definition.

Omer: What do “too many details” has to do with that?

Erez: Well...in fact...maybe it is.

Zaslavsky and Shir wrote:

In general, the issue of minimality elicited debate and discussion surrounding its imperativeness. These discussions ended in an agreement that, although there might be cases in which a minimal definition is preferable, minimality is not an imperative feature of a mathematical definition (p. 328-329).

The authors also asserted that the above dialogue captured the moment when Erez began rethinking the issue of minimality and that later he was willing to consider a non-minimal statement as a definition. Interestingly, Zaslavsky and Shir indicate in *Theoretical Perspectives* section of their paper that there is considerable lack of agreement even in mathematics education research community about the issue. This is the essence of the debate: the researchers, who claim that mathematical definitions should be minimal, usually present mathematical-logical reasons; their opponents recognize the role of social context and stress that some non-minimal definitions are clearer and more appropriate for communication than the minimal ones.

My point here is that it is easy to re-analyse the above findings and the debate using considerations of parsimony. Indeed, why, from one's perspective, should a definition be minimal? Because of the classic, ontological, principle of parsimony, namely, when constructing a theory<sup>1</sup>, one should not make more assumptions than the minimum needed. Why, from another's perspective, may a definition be not minimal? Because of the paraphrased principle of parsimony, namely, when achieving a goal (for instance, a goal of communicating a concept with other people), one intends not to make more effort than the minimum needed. Further, why did Erez rethink his position about minimality of mathematical definition? Because he was influenced by two aforementioned kinds of parsimony, encountered cognitive dissonance and tried to resolve it by adopting more flexible position regarding the issue of minimality. To recall, *cognitive dissonance* means the ability of a person to simultaneously hold at least two opinions or beliefs that are logically or psychologically inconsistent (Festinger, 1957).

### **Example 2: When do efficiency and elegancy conflict in problem solving?**

Koichu & Berman (2005) documented the following phenomenon: gifted high-school students, trained in solving olympiad-style mathematics problems, experience cognitive dissonance between their conceptions of *efficiency* and *elegancy* in doing mathematics. Specifically, they express mixed feelings when solving problems, presumably solvable within Euclidian geometry, using advanced analytical or trigonometric techniques.

---

<sup>1</sup> Certainly, constructing or choosing a definition *can* be qualified as a part of theory constructing.



Consider some data presented in Koichu and Berman (2005). Mike, a medallist of several IMOs, was asked to think aloud when solving the following problem: *Prove that if two bisectors of a triangle are equal, then it is an isosceles triangle*<sup>2</sup>.

After reading the problem, Mike said in response to the interviewer prompt "what are you thinking about" (p. 173):

Mike: I am choosing the way ... On the one hand, the problem can be solved geometrically, but I am not sure how... On the other hand, I am sure that it can be solved algebraically, but I feel too lazy to do so. Indeed, I can write  $a, b, c$  [to denote the sides of a triangle], to compute everything and at the end, I know exactly, for 100%, everything will be all right.

Mike indeed realized his plan and solved the problem algebraically in about 5 minutes. Apparently, the words "I am too lazy to do so" meant that Mike wanted the interviewer to withdraw the request to solve the problem, which solution was so clear and simple to the gifted and well-prepared student. Nevertheless, Mike was not satisfied with his (algebraic) solution. For the next 5 minutes, he unsuccessfully tried to solve the problem geometrically. Then he said (p. 174):

Mike: The first solution intersects my thinking, I am just trying to translate algebra into geometry, it is not fair...I am sure that there is a purely geometrical solution, but it is more difficult to find.

Interviewer: Why?

Mike: It is unclear what to do. I mean... algebra... For example, we should prove something—OK, we represent it algebraically, and at the end everything works.

Interviewer: And what exactly is difficult in geometrical solutions? Sometimes there are very short...

Mike: One should have an insight to figure out what to do. Sometimes, if you have experience..., you can get it, but very often you cannot...or it takes a lot of time.

Trained to solve problems at mathematical competitions under pressure and time constraints, Mike chose the most *efficient*-the least time consuming-solution method. This is in line with Dreyfus & Eisenberg's (1986) observation that an opportunity to have an immediate picture of a solution can override aesthetic concerns in expert problem solving.

It is easy to see that affective colouring of algebra-laden and geometry-laden approaches in the Mike's problem solving includes considerations of parsimony. Indeed, Mike's problem solving behaviour heavily relies on the principle "not to make more intellectual effort than the minimum needed". However, it looks like Mike takes into account different kinds of intellectual efforts and decides which problem solving approach is worth trying based on the estimation of effort needed either to get an insight, as in geometry-laden solutions, or to perform a not insightful routine, as in algebra-laden solution.

---

<sup>2</sup> This problem is a counterpart of the famous Steiner-Lehmus theorem, which looks like an easy-to-prove statement but, in fact, is not.

In addition, Koichu and Berman suggested in their paper that Mike's and other gifted students' problem solving behaviours were driven by one more version of the principle of parsimony: "For the sake of elegance, one should use no more mathematical tools than the minimum needed" (p. 177). Note that this version is closer to the classic, ontological, Ockham's razor than to the paraphrased one (cf. Menger, 1960).

### Example 3: When can't one see the forest for the trees?

The following task<sup>3</sup> was given to a group of 8<sup>th</sup> graders in the experiment reported in Koichu, Berman and Moore (2007):

Let  $n! = 1 \cdot 2 \cdot 3 \cdot \dots \cdot (n-1) \cdot n$  be the product of all positive integers from 1 to  $n$ .

Calculate:  $\frac{(6!)(4!)}{(5!)(3!)}.$

Koichu et al. elaborated (p. 108) that most of the students saw the definition of  $n$ -factorials for the first time in their lives and started from checking the given definition of  $n$ -factorials for concrete numbers. They calculated  $6! = 1 \cdot 2 \cdot 3 \cdot 4 \cdot 5 \cdot 6 = 720$ ,  $5! = 1 \cdot 2 \cdot 3 \cdot 4 \cdot 5 = 120$  etc. Then they used the results of their computations in order to handle the task, which led them to the following solution:

$\frac{(6!)(4!)}{(5!)(3!)} = \frac{720 \cdot 24}{120 \cdot 6} = \frac{17280}{720} = 24$ . Few students completed the last division since

calculators were unavailable. When the same task was given to a group of undergraduate students, they, not surprisingly, solved it immediately:

$\frac{(6!)(4!)}{(5!)(3!)} = 6 \cdot 4 = 24.$

I argue here that the solutions of either 8<sup>th</sup> graders or undergraduate students were driven by the principle "not to make more intellectual effort than the minimum needed". In the case of the 8<sup>th</sup> graders, the parsimony of intellectual effort was reflected in their decision not to fling away the computations that have been done so far - they just continued them without seeing the overall picture of the solution. In the case of the undergraduate students, who obviously could see the overall picture of the solution, the intellectual parsimony was reflected in the immediate decision to decompose the given fraction into its easily reducible parts.

This example points out that considerations of intellectual parsimony can be found not only in expert problem solving; they are much more common than one can imply from looking at mathematics education literature. Note also that the idea of balancing different kinds of parsimony, which was stressed in two previous examples, is hardly applicable to the third example. Indeed, it was not observed that the 8<sup>th</sup> graders hesitated when using the results of their preparatory calculations in the main one; they just acted as parsimoniously as they could.

<sup>3</sup> The task is adapted from SAT-M and utilized in Koichu et al.'s research as a part of a questionnaire aimed at measurement of mathematical aptitude of middle school students.

## **DISCUSSION AND IMPLICATIONS**

This paper supports the claim that considerations of parsimony, in general, and balancing different kinds of parsimony (e.g., epistemological, logical-mathematical, communicative), in particular, should be considered as one of cognitive mechanisms driving mathematical problem solving. As a matter of fact, the paper calls to look for considerations of parsimony in various problem-solving phenomena. Several questions emerge from the presented arguments, and I briefly discuss two of them.

### **How can considerations of parsimony complement existing models of problem solving?**

One of the most advanced empirical models of mathematical problem solving is that by Carlson & Bloom (2005). It relies on the earlier models (e.g., of Schoenfeld, 1985, and Verschaffel, 1999), and postulates four phases in problem solving: orientation, planning, executing and checking. The model also includes a sub-cycle “conjecture-test-evaluate” and various problem-solving attributes, such as conceptual knowledge, heuristics, metacognition, control and affect. The model is sophisticated and descriptive in nature. Incorporating considerations of parsimony in the model, as one of the forces driving one's switching from the phase to phase and from the cycle to cycle, can strengthen its explanatory power.

Similar arguments can be applied to the model presented at PME-2006 by Koichu, Berman and Moore. In our work, we distinguished four patterns of heuristic behaviours observed in middle school students. The patterns vary with respect to the numbers of (local) heuristics used in a solution to a given problem, heuristics used at the beginning of the solution and sub-sequences of heuristics used in succession (see also Koichu et al. 2007). Considerations of parsimony - a meta-heuristics - can explain the use of local heuristics in our data and help find additional patterns in different problem-solving behaviours (cf. Example 3).

### **Why can it be beneficial to think on problem solving in terms of intellectual parsimony?**

I address this question by appealing to the literature concerning the role of models and theories in mathematical education. According to some frequently cited literature sources (e.g. Schoenfeld, 2002; Dubinsky & McDonald, 2001), in order to be useful a model or a theory should: support prediction, have explanatory power, be applicable to a broad range of phenomena, help organize one's thinking about complex interrelated phenomena, serve as a tool for analysing data, and provide a language for communicating ideas about learning that go beyond superficial descriptions. So far, it looks like theorizing on the role of considerations of parsimony in mathematical problem solving fits most of these criteria. In addition, it is in line with the recent call to explore in depth cognitive mechanisms that seem to govern the observed problem-solving phenomena (cf. Harel, 2006; in press).

On top of that, thinking on mathematical problem solving in terms of the principle of parsimony can be beneficial as it has great potential for better connecting

mathematics education to other research fields. Indeed, the ubiquitousness of considerations of parsimony in different situations may imply that some sort(s) of the principle of parsimony is (are) embedded in brain, not just in mind. I am fully aware that this point is particularly speculative. At the moment, it is based on the expectation that on-going attempts to bridge educational research with neuroscience, AI and evolutionary psychology will eventually succeed.

In closing, it is natural to ask in this paper: is the assumption of intellectual parsimony in mathematical problem solving parsimonious by itself? In other words, is the addition of this assumption forced by the evidence that otherwise cannot be satisfactory explained? So far, I believe that it is. Viability of this belief will hopefully be examined in future (interdisciplinary?) research.

## References

- Baker, A. (2004). Simplicity. In E. N. Zalta (Ed.), *The Stanford Encyclopaedia of Philosophy*, Retrieved January 11, 2008 from <http://plato.stanford.edu/archives/win2004/entries/simplicity/>.
- Cai J., Mammona-Downs, J., & Weber, K. (2005). Mathematical problem solving: What we know and where we are going. *Journal of Mathematical Behavior*, 24, 217-220.
- Dreyfus, T. & Eisenberg, T. (1986). On the aesthetics of mathematical thoughts. *For the Learning of Mathematics*, 6(1), 2-10.
- Dubinsky, E. & McDonald, M. (2001). APOS: A constructivist theory of learning in undergraduate mathematics education research. In D. Holton (Ed.), *The Teaching And Learning of Mathematics at University Level: An ICMI Study*, pp. 275-282, Kluwer.
- Festinger, L. (1957). *A Theory of Cognitive Dissonance*. Stanford, CA: Stanford University.
- Foster, M. (2000). Key concepts in model selection: Performance and generalizability. *Journal of Mathematical Psychology*, 44(1), 205-231.
- Goldin, G. (1998). Representational systems, learning, and problem solving in mathematics. *Journal of Mathematical Behavior*, 17(2), 137-165.
- Goldin, G. (2000). Affective pathways and representation in mathematical problem solving. *Mathematical Thinking and Learning*, 2(3), 209-219.
- Harel, G. (2006). Mathematics Education Research, Its Nature, and Its Purpose: A Discussion of Lester's Paper, *Zentralblatt fuer Didaktik der Mathematik*, 38, 58-62.
- Harel, G. (in press). What is mathematics? A pedagogical answer to a philosophical question. In R. B. Gold & R. Simons (Eds.), *Proofs and Other Dilemmas: Mathematics and Philosophy*. Mathematical American Association. Retrieved January 13 from <http://math.ucsd.edu/~harel/downloadablepapers/Harel%27s%20WhatIsMathematics.pdf>
- Koichu, B. & Berman, A. (2005). When do gifted high school students use geometry to solve geometry problems? *The Journal of Secondary Gifted Education*, 16(4), 168-179.
- Koichu, B., Berman, A., & Moore, M. (2006). Patterns of middle school students' heuristic behaviors in solving seemingly familiar problems. In J. Novotna, H. Moraova, M. Kratka, & N. Stehlikova (Eds.) *Proceedings 30<sup>th</sup> Conf. of the International Group*

- for the Psychology of Mathematics Education* (Vol. 3, pp. 457-464). Prague, Czech Republic: PME.
- Koichu, B., Berman, A., & Moore, M. (2007). Heuristic literacy development and its relation to mathematical achievements of middle school students. *Instructional Science*, 35, 99-139.
- Krutetskii, V. (1976). *The Psychology of Mathematical Abilities in Schoolchildren* (J.Teller, Trans.). Chicago: University of Chicago Press. (Original work published 1968).
- Lester, F.K. (1994). Musings about mathematical problem-solving research: 1970-1994. *Journal for Research in Mathematics Education*, 25(6), 660-675.
- Menger, K. (1960). A counterpart of Ockham's razor in pure and applied mathematics: Ontological uses. *Synthese*, 12, 415-420.
- Orton, R. E. (1995). Ockham's razor and Plato's beard. *Journal for Research in Mathematics Education*, 26(3), 204-229.
- Rowlands, S. (2001). The contradictions in the constructivist discourse. *Philosophy of Mathematics Education Journal* 14, Retrieved January 11, 2008 from <http://www.people.ex.ac.uk/PErnest/pome14/rowlands.htm>
- Schoenfeld, A. H. (1985). *Mathematical Problem Solving*. New York, NY: Academic Press.
- Schoenfeld, A. H. (2002). Research methods in (mathematics) education. In L. English (Ed.), *Handbook of International Research in Mathematics Education* (pp. 435-487). Mahwah, NJ: Erlbaum.
- Sinclair, N. (2004). The role of the aesthetics in mathematical inquiry. *Mathematical Thinking and Learning*, 6(3), 261-284.
- Sober, E. (1979). The principle of parsimony. *The British Journal for the Philosophy of Science*, 32(2), 145-156.
- Verschaffel, L. (1999). Realistic mathematical modelling and problem solving. In J. H. M. Hamers, J. E. H. Van Luit, & B. Csapo (Eds.), *Teaching and Learning Thinking skills* (pp. 215-239). Lisse: Swets and Zeitlinger.
- Zaslavsky, O. & Shir, K. (2005). Students' conceptions of a mathematical definition. *Journal for Research in Mathematics Education*, 36(4), 317-346.

# DEVELOPMENT OF MATHEMATICS TEACHER STUDENTS' TEACHER IDENTITY DURING TEACHING PRACTICE

Heidi Krzywacki-Vainio and Markku S. Hannula

University of Helsinki

*Mathematics teacher education programmes typically combine studies in mathematics and in education. In this article we present two case studies, which show how students' identity as a teacher in mathematics changes as they move from mathematics department to the department of education. During their studies in university level mathematics, teacher students have developed a view of an ideal teacher. When teacher students enter educational studies and experience teaching practice, this view changes. For some, this may even be the actual starting point for the construction of their own identity as a teacher. The case studies especially illustrate a change in how teacher students see the role of the subject matter knowledge in teaching.*

## INTRODUCTION

Mathematics teacher education has two different emphases, which causes a tension in teacher education programmes. On one hand, mathematics teachers are subject specialists, who are assumed, in most countries, to master the study of mathematics, including a significant amount of university courses in mathematics, and on the other hand, they are assumed to become competent in various teaching methods and classroom management. For the latter purpose, teacher students take courses in education, in subject didactics, and they also do teaching practice. The tension between subject studies and educational studies becomes difficult when after some years of 'enculturation' into being a mathematics student, teacher students are requested to develop new identities as autonomous, reflective and critical mathematics teachers.

The education programme for Finnish master's degree pre-service mathematics teachers (300 credit points) consists of studies in university mathematics as a major (150 cp), studies in another school subject (60 cp) and one year of educational studies (60 cp) including supervised teaching practice modules (20 cp). Despite the intended specialisation teacher students take only one special course (12 cp) on master's level, which focuses on integrating university mathematics with school contents. Usually, the educational studies are completed after 4th or 5th study year (see Lavonen, Krzywacki-Vainio, Aksela, Krokfors, Oikkonen, & Saarikko, 2007).

## THEORETICAL BACKGROUND

The theoretical framework is based on a concept of individual teacher identity and its formation during teacher education. A literature review points to three essential features of teacher identity and its formation. Firstly, image of an ideal teacher is essential in formation of individual teacher identity (Sfard & Prusak, 2005; Arnon & Reichel, 2007). Based on their experiences as mathematics learners, students have

conceptions of good teaching and learning in mathematics, especially of ability, and skills needed as a mathematics teacher. The image of an ideal teacher changes through interaction with others, not only during teacher education but further in schoolwork as well. At the same time, teacher students reflect on their present state based on their experiences and notions of similarities and differences with others. Formation of teacher identity may be seen as a process of filling the gap between present and ideal images (Sfard & Prusak, 2005). Identity is seen as contextual, i.e. in different situations one may assume different identities, which may sometimes appear as inconsistent behaviour. Moreover, we see identity as dynamic and never fixed, as it is continually in flux and under construction (e.g., Danielewicz, 2001). Yet, a state of identity can be recognised in a specific moment and context, which makes it possible to reflect and research one's identity.

Secondly, this time and context specific teacher identity can be characterised through different cognitive and affective properties of the individual, which are related to teacher profession. From a cognitive viewpoint, teacher identity is associated with professional knowledge and skills in subject matter, pedagogy, and didactical issues (Beijaard, Verloop, & Vermunt, 2000; see also Shulman, 1987). In this research, a special interest is directed to the integration of mathematical knowledge into teacher student's process of becoming a teacher. In addition to cognitive aspects, teacher identity includes an affective aspect (e.g., Hodgen and Askew, 2007). Individual feelings and beliefs attached to becoming and being a teacher arise during teacher education, especially when acting as a teacher in teaching practice.

Thirdly, and perhaps most fundamentally, teacher identity is something that is constructed. It remains a challenge to support teacher students' engagement in the intrinsic processes related to formation of teacher identity during teacher education. Danielewicz (2001) discusses the crucial meaning of engagement in becoming and being a good teacher. In academic teacher education, the basic idea is that teacher students should be willing to develop themselves as teachers. This means that they should be aware of their competence, and that they should intentionally fill the gap between present and ideal image representing conscious personal aims. Using the concept of teacher identity, we also acknowledge the difference between acting as a teacher and being a teacher, i.e. adopting teacher identity (Beijaard et al., 2000; Danielewicz, 2001). The growth of academic mathematical knowledge has a central role in teacher education at Finnish universities. However, as Atkinson (2004) claims, it is not simple to offer the proper, stimulating learning environment for teacher students. Teacher identity cannot be influenced directly, and students will not adopt all knowledge and skills offered during the teacher education programme (Korthagen, 2004).

The experience of taking a role as a teacher in the first teaching practice period is critical as students have to face their starting points as teachers in practice. We expect students to conceptualise both an ideal image of being a teacher and the present phase of their own development at this stage. In this paper, we will focus on the meaning of

expertise in mathematical knowledge for formation of individual teacher identity during mathematics teacher education. The research question is how the student's view of the meaning of mathematical competence changes after experiencing teaching practice.

## **METHODS**

Altogether 18 teacher students took part voluntarily in three semi-structured interviews during their educational study year 2005-2006 at the Department of Applied Sciences of Education in Helsinki. In this article, we focus on two of the interviewed teacher students, Anni and Teppo. They were selected because they represent students who show two different, but typical, development processes during studies. To improve construct validity, we have used students' reflective portfolios as well as feedback questionnaires on educational studies.

The following themes were discussed in the interviews:

- A starting point and the background of a teacher student
- Conceptions of good teaching and being a teacher in mathematics (an ideal image of mathematics teacher)
- Identification as a teacher
- Expectations and aims for the studies
- Evaluation of the studies in relation to personal development as a teacher

The research uses a qualitative approach. The interview data was analysed following the principles of the analytic induction, starting with the themes of the interview described above (cf. Patton 2002). The themes on identification as a teacher, conceptions on mathematics teaching, and being a teacher, and the evaluation of studies were discussed in all three interviews.

## **RESULTS**

Here, we focus on two students, Anni and Teppo. We shall describe their initial view of an ideal teacher and themselves as teachers, with a specific attention to the role of subject matter knowledge.

### **Anni**

Anni was well motivated for becoming a mathematics teacher. She had no prior teaching experience. She had difficulties with mathematics at the beginning, but has enjoyed it since. It took her one year of studies in mathematics to realise, that her wish to become a teacher and her enjoyment in mathematics could be combined. She would have wanted to learn more pedagogical viewpoints already during the courses in mathematics. She felt, that the path of becoming a teacher is not addressed in mathematical education. She has also experienced some scorn for the lack of mathematical expertise of future teachers.

...students seem to be divided into those who are really talented, and then to those who are not so lost somewhere in spaces of infinite dimensions, and so they are going to be teachers... so, I feel somewhat like... (autumn).



Already before entering the first teaching practice Anni had a well-developed view on an ideal teacher. She discussed the meaning of subject matter knowledge as a basis for clarity in teaching mathematics. Her ideal mathematics teacher would be interested in and enthusiastic about mathematics. Although an ideal teacher would be skilful enough in mathematics, being a teacher is more about motivating and supporting pupils learning processes.

... you have to be enthusiastic about it, and you also have to know the content well enough in order to be able to present it clearly and don't have to wonder how it is... in other words, you need to be skilful and enthusiastic (autumn).

Before teaching practice, Anni found her subject matter knowledge good enough, at least according to her test results, but she questions her real mathematical ability to teach on upper secondary school level. She worries whether she is able to form a credible authority as a teacher.

Anni didn't have particular aims for educational studies but seemed to be excited about having a clear aim at becoming a teacher for the first time in her studies. She had quite high expectations, especially for supervised teaching practice, which was her first opportunity to act as a teacher. Her personal aims for teaching practice were related to practical things and acting as a teacher in classroom. Overall, she was willing to learn everything that was offered over the study year. She discussed her need to link theoretical knowledge with practical skills in school context.

After the first supervised teaching practice, Anni's ideal teacher was still mathematically competent, but pedagogical knowledge and social skills played a more important role. Regarding her skills, she concluded that she had found enough of her mathematical competence, at least in those particular situations during the teaching practice, but she still suffers with some lack of self-confidence.

Her need for mathematical knowledge had become more tightly related to classroom actions. It was the basis for acting in dynamic classroom situations, answering unexpected questions, and reasoning. Thus, subject matter knowledge was essential for feeling confident as a teacher in continuously changing classroom situations. Anni wondered whether all university mathematics was essential but she was sure that a teacher has to know enough to make pedagogically good decisions in the classroom.

... if you think about the amount of mathematical education here, it's probably too much compared to what you will need as a teacher but, enough in order to understand the mathematical background as well, it also clarifies your own mathematical background, or you know what is being taught and where it all comes from (December).

... subject matter knowledge seems to be, however... a little bit ... I don't know about it... not sure how well I really know mathematics... (December).

However, she felt that she had been able to link university mathematics with school mathematics in some points.

After going into pretty deep level in mathematics, it is somehow really clear in my mind what is taught in upper secondary school, so then it must be quite useful, even if I had wanted to study more things related to teaching, not so much just ‘hard’ mathematics... maybe I will gradually realise how useful it is (December).

At the end of the first teaching practice period, Anni discussed the meaning of practical experiences in classroom. The meaning of mathematical competence acquired through mathematical education had changed because of the practical experience. Earlier the idea of her own development as a teacher had not really touched her personally.

Altogether, teaching practice was the best part of my educational studies so far. I think I have developed as a teacher a lot. Now that I know approximately what kind of a teacher I am, it is a good starting point for further self-development and the growth of my competence [as a teacher] (portfolio, December).

### **Teppo**

Teppo gave no clear reason for choosing the teacher education programme. After studying mathematics at university for several years, there were no better options but to become a teacher. He had not been aware of any future profession when studying university mathematics. When talking about mathematical education, he emphasised his own learning process and personal feelings about university mathematics.

... well, somehow scientific or such, mathematical [way of thinking], I don't know how to explain, I only remember how difficult it was, the definition of limit at first... it was difficult for me to understand and after I got it, nothing was as difficult for me since... somehow I got into that way of thinking (spring).

Before teaching practice, conceptualising an image of an ideal teacher was difficult for Teppo. An ideal mathematics teacher should be enthusiastic about mathematics itself. Other than that, his view of being a teacher was based on separate pieces of knowledge and did not constitute a coherent picture. On the other hand, mathematical education for him was a personal process of learning to reason mathematically. He stressed that subject matter knowledge would be relevant for a teacher, as one would have to know school mathematics in general.

... well, of course it is a good thing to be as good as possible in the subject itself, so it is important and on the other hand in that particular topic to be taught... (autumn).

His main aim for educational studies was to have a feeling about being a teacher and to find out whether and what kind of a teacher he would like to be, and, finally, to graduate. It is not surprising that Teppo found the idea of continuous development difficult and somewhat stressful. Teppo admitted that he was not able to reflect his own needs at this point.

... I don't know yet what I'm going to need, it's like doing something for the first time and then you don't know how to prepare yourself for it, and in these studies, the situation is similar with all these [educational] studies. I don't have any aims yet, but they probably will arise during this year (autumn).

After some classroom experience, Teppo still associated mathematical competence with being a good teacher. Besides, he now stressed, that further development can also take place at work. According to Teppo, good teaching and learning were not only based on mathematical competence, but also on good preparation of lessons and detailed planning. Mathematical knowledge would need to be combined with pedagogical decisions. Transformation of mathematical knowledge from university level to school mathematics suitable for pupils would be a challenge to be dealt with.

Well, in my opinion it is really important that he [a teacher] can find out, half of the preparation work... to solve a task and, while doing that, think about what things are important to teach and what is the relevant teaching phase (December).

Overall, teaching practice had clarified the image of an ideal teacher. Still, Teppo was not conscious of his personal aims or the role of mathematical knowledge in being a teacher. The image of an ideal teacher was not guiding his development at this point and, for example, he was highly dependent on mentoring in teaching practice.

Teppo considered himself as a teacher almost the very first time in teaching practice. Before, mathematical knowledge had been enough. Mathematical knowledge had now been put to test in the classroom, not only through his own mathematical competence but a view on the role of university mathematics for a teacher. It seems that he realised the meaning of mathematical education in a new way, as part of being a teacher. Teppo had a hard time understanding pupils' difficulties in the classroom.

... but then it is good to master some pieces of knowledge even more thoroughly, for example in my opinion, it is really useful to understand algebra, groups and other things like that, to understand features of multiplication and addition... it's strange for me to observe how difficult it is for pupils to understand that multiplication and addition are essentially different things... (December)

Teppo reflected his mathematical competence as a teacher with contradictory consequences. Teppo evaluated his own mathematical competence to be insufficient, but based on the feedback in teaching practice he felt that his social skills could be seen as his strength. He saw an improvement with his competence in mathematics, his understanding of 'hard' mathematics as a solution for mastering dynamic classroom situations more confidently. The gaps in subject matter knowledge could be fixed through thorough lesson preparation. After teaching practice, his attitude towards the meaning of skills and knowledge in mathematics changed: being a mathematics teacher would also require social skills.

Teppo became more aware how to act as a teacher. Self-reflection was difficult for him and while studying mathematics had been personal process for him, it was not particularly related to future profession. He understood the limits of his mathematical competence in the classroom. However, he found conceptualising his own development and becoming aware of issues that needed to be developed a challenge. The connection between an ideal image and his personal development didn't take place.

## CONCLUSIONS AND DISCUSSION

In this article we focused on two students who had no teaching experience before their educational studies at the department of education. Before teaching practice, their views of an ideal teacher emphasised content knowledge of university mathematics, which is quite similar to the views of the teacher educators at the mathematics department (Krzywacki-Vainio, submitted). However, this view seems to fail the test of reality, as the notion of an ideal teacher changes during teaching practice - these two cases in this study are only examples of a general trend. Especially for students like Teppo, their first experience in front of the class is only the beginning of the formation of their teacher identity. Taking a role of a teacher in public is meaningful for the engagement into and for the process of identity formation (see Danielewicz, 2001). For those who were already committed to become teachers (the case of Anni), teaching experience significantly changes their view of an ideal teacher and their personal teacher identity.

Mathematical education within the programme consists mainly of 'hard' mathematics, hence, during the first three years of studying, aiming at professional development depends on each individual students' own orientation. In this phase before entering educational studies, formation of teacher identity is more about reshaping and clarifying the image of an ideal teacher and probably the personal aims for future studies. Motivational background is essential, as the cases of Anni and Teppo show. Students with clear intentions to become a teacher would have use for pedagogically oriented mathematics courses. At the same time, students who are unsure about their future career enjoy their personal mathematical learning process with no actual connection to the formation of professional identity.

Formation of teacher identity should start at the beginning of the studies. Still, the meaning of university mathematics for individual teacher students seems to vary according to commitment to become a teacher. Academic cognitive skills and knowledge are strongly emphasised in the programme, whereas personal processes of identity formation receive less attention. Mathematical knowledge is considered the solid base for becoming a teacher. However, like the cases of Anni and Teppo show, only the first teaching practice is critical when students take a role as a teacher and individual mathematical competence is needed in the classroom.

After the first teaching practice, the meaning of mathematical knowledge and skills is reconsidered. Taking the role as a teacher and having a chance to identify with future profession seems to be a critical point in the programme. Through teaching experience, students might be able to reflect their own readiness for teaching mathematics from the viewpoint of subject matter knowledge. Even originally poorly motivated students, like Teppo, face up to practical issues of being a teacher. Both mathematical education and experiences in teaching practice influence development towards the future profession. However, the process is not straightforward, as through practical experiences the basic knowledge in university mathematical gets new meanings.

## References

- Arnon, S. & Reichel, N. (2007). Who is the ideal teacher? Am I? Similarity and difference in perception of students of education regarding the qualities of a good teacher and of their own qualities as teachers. *Teachers and Teaching: Theory and Practice*, 13(5), 441-464.
- Beijaard, D., Verloop, N., & Vermunt, J. (2000). Teachers' perceptions of professional identity: an exploratory study from a personal knowledge perspective. *Teaching and Teacher Education*, 16(2000), 749-764.
- Danielewicz, J. (2001). *Teaching Selves: Identity, Pedagogy, and Teacher Education*. State University of New York Press: Albany.
- Hodgen, J. & Askew, M. (2007). Emotion, identity and teacher learning: becoming a primary mathematics teacher. *Oxford Review of Education*, 33 (4), 469-487.
- Korthagen, F. A. J. (2004). In search of the essence of a good teacher: towards a more holistic approach in teacher education. *Teaching and Teacher Education*, 20(2004), 77-97.
- Krzywacki-Vainio, H. (submitted). Pre-service mathematics teacher education orienting formation of teacher identity - mathematical education as the basis for development. Manuscript submitted for Topic Study Group 29 in ICME 11.
- Lavonen, J., Krzywacki-Vainio, H., Aksela, M., Krokfors, L., Oikkonen, J., & Saarikko, H. (2007). Pre-service teacher education in chemistry, mathematics and physics. In E. Pehkonen, M. Ahtee, & J. Lavonen (Eds.), *How Finns Learn Mathematics and Science*. Sense Publishers: Rotterdam/Taipei.
- Patton, M. Q. (2002). *Qualitative Research and Evaluation Methods* (3rd edition). Sage Publications: Thousand Oaks.
- Sfard, A. & Prusak, A. (2005). Telling identities: in search of an analytic tool for investigating learning as a culturally shaped activity. *Educational Researcher*, 34(4), 14-22.
- Shulman, L. S. (1987). Knowledge and teaching: Foundations of new reform. *Harvard Educational Review*, 57, 1-22.

# FOSTERING GEOMETRICAL PROOF COMPETENCY BY STUDENT-CENTRED WRITING ACTIVITIES<sup>1</sup>

Sebastian Kuntze

University of Munich

*For understanding and generating geometrical proofs, students need a basic understanding of proving as a mathematical activity. Creating opportunities for reflection processes about the nature of proof by asking the students to write texts on different aspects of proving is a possibility to foster such proof-related meta-knowledge. Results of two empirical studies indicate that the students' proof competency can be improved by a corresponding learning environment, the so-called topic study method.*

## INTRODUCTION

Repeatedly, difficulties of students when having to generate mathematical proofs have been observed. These findings call for research on instructional interventions aiming at fostering proof competency.

As far as known to the author, this is the first quantitative empirical paper examining effects of a writing task learning environment on geometrical proof competency. In the learning environment, the students were encouraged to reflect on the nature of proving in mathematics and to write texts - so-called topic studies - on this subject. The learning environment focused on proof-related meta-knowledge. The findings in two corresponding studies indicate positive effects on the competency of solving proving tasks for secondary and for university students. Moreover, the results suggest that the writing task increased their conceptual knowledge about generating proofs.

The following section gives an overview on the theoretical background of the paper. After deducing research questions, the samples of two studies and their design are described. Finally, the paper reports on the results of both studies, before discussing and interpreting the evidence.

## THEORETICAL BACKGROUND

Increasingly, competencies linked to mathematical argumentation and proving are being looked at as a substantial component of mathematical literacy. For example, according to the Principles and Standards of the National Council of Teachers of Mathematics (NCTM, 2000, p. 56), all students should be enabled to “recognize reasoning and proof as fundamental aspects of mathematics”, “make and investigate mathematical conjectures”, “develop and evaluate mathematical arguments and proofs” and “select and use various types of reasoning and methods of proof” (for a critical discussion cf. Stylianides & Stylianides, 2006).

---

<sup>1</sup> This research was supported by the “Deutsche Forschungsgemeinschaft” (German re-search council) within the priority program „Bildungsqualität von Schule“ (RE 1247/4).

However, students often encounter difficulties when generating or evaluating proofs (Reiss, Klieme and Heinze, 2001; Healy & Hoyles, 1998; Lin, 2000; Reiss, Hellmich & Reiss, 2002). Such difficulties are often attributed not only to requirements of problem solving or deficits in basic knowledge - e. g. of geometrical concepts - but also to lacking knowledge about proving strategies and heuristics. In fact, students need a basic understanding of proving as a mathematical activity. This basic understanding encompasses a certain range of aspects of meta-knowledge about proof in mathematics: For instance, the three aspects methodological knowledge about proof, knowledge about the development of proofs, and knowledge about functions of proving seem essential or can probably enhance proving abilities of the learners:

*Methodological knowledge about proof* as described by Heinze & Reiss (2003) encompasses the three aspects of proof scheme, proof structure and logical chain, describing criteria when an argumentation can be considered a correct mathematical proof. In existing tests focusing on methodological knowledge, students are asked to evaluate argumentations (e. g. Healy & Hoyles, 1998; Selden & Selden, 1999).

*Knowledge about the development of proofs* as described in the expert model of Boero (1999) might be very useful for learners when they have to prove on their own. Especially the central role of heuristic strategies experts use might encourage students to engage in explorative activities before linking arguments in a logical chain.

*Functions of proving and proof* (De Villiers, 1990; Hanna, 2000; Kuntze, 2005) might be an important area of meta-knowledge on proof because it can help to explain to what ends proofs are generated in the discipline of mathematics. A central idea is that conjectures are not only proven in order to verify them or to establish their truth, but that the activity of generating proofs also facilitates an in-depth understanding of underlying mathematical problems. Moreover, proving has the function of communicating and transferring mathematical knowledge, promoting mathematical discoveries, convincing colleagues etc.

For geometrical proof, competency models have been developed and verified empirically (Reiss, Klieme, & Heinze, 2001; Reiss, Hellmich and Reiss, 2002) by using the one-dimensional Rasch model. The areas of proof-related meta-knowledge presented above are considered as variables possibly influencing proof competency and its development. In short terms, proof competency could be fostered by fostering meta-knowledge on proving as a mathematical activity.

One way to create learning opportunities for the development of proof-related meta-knowledge is to encourage reflections on proofs, e. g. on their structure and on means of argumentation, on the functions of proving and on how proofs are generated. As stated e. g. by Morgan (2001), writing tasks have the potential of supporting deepened reflection processes on mathematical concepts. In order to foster meta-knowledge about mathematical proof by writing on a reflection task, we chose the so-called topic study method (Kuntze, 2006a, b). In this learning environment, the students are confronted with heterogeneous materials (like e. g.

argumentations of pupils containing mistakes or unfinished proofs calling for evaluations, meta-scientific texts about proving and the development of proofs, citations of mathematicians about the role and practice of proving, law norms for proof in criminal proceedings, fragments of interviews with students about proof, etc.). Linking or discussing the ideas in these documents, the students have to produce individual texts giving an overview on proving and on what it is about. The choice to design this learning environment was also based on the results of an overview study by Herrick (2005). In this study, which refers to 55 quantitative studies mainly from English-speaking countries, writing activities in mathematics classrooms had at least no negative effects on achievement outcomes and motivation compared to conventional teaching, whereas positive effects on problem solving competencies, as well as on the use of cognitive and metacognitive strategies were observed.

## RESEARCH QUESTIONS

As we assert that fostering meta-knowledge on proving can enhance proof competency, we expect that the writing task learning environment has a positive effect on proof competency. Accordingly, the study aims at providing evidence for the following research questions:

- (i) Can writing activities focusing on meta-knowledge on mathematical argumentation and proof foster geometrical proof competency?
- (ii) Can conceptual knowledge on generating proofs be supported by the writing activities contained in the topic study method?

## METHODS AND SAMPLE

The research questions were explored in two studies. One of the core aims of the *first study* was to find out whether the writing task in the topic study method could be implemented under realistic conditions of upper secondary schools. However, according to the first research question, a first approach to a quantitative evaluation was made by including measures of proof competency in a pre- and post-test.

In this study, the participating grade eight students (aged about 12 years) were divided into two groups which received different treatments in two corresponding learning environments. The first learning environment was the topic study method containing the writing task as described above.  $N_1=121$  students (63 girls and 58 boys) were asked to write a text about proving and proof based on fragments of texts which were handed out to the students as facilitating material for reflecting on mathematical proof.

The second learning environment (further on referred to as “reference learning environment”) consisted in the so-called “learning with heuristic examples” (Reiss and Renkl, 2002; Heinze, Reiss and Groß, 2006). In this second learning environment,  $N_2=111$  students (55 girls and 56 boys) worked on proving tasks presented to them in the form of worked out examples including prompts which



concentrated on an additional support in heuristic strategies focusing on the process of generating proofs. This reference treatment has turned out to be more effective than conventional instruction on geometrical proof in other studies (cf. Hilbert et al., in press; Heinze et al., 2006) and served therefore as a reference for evaluating the topic study method. There was no control group without training in the first study.

The *second study* attempted to focus more closely on learning outcomes of writing tasks about mathematical proof. Consequently, two types of control groups with a defined treatment were included and the learning time was controlled in a much more consequent way than this had been possible under the field conditions of the first study. In order to meet these requirements, the learners in the second study were university students at the beginning of their studies of primary education. As the study took place before the start of the first course of mathematics and mathematics education, it can be assumed that mathematics-related knowledge taught in this course did not interfere. In the second study, the writing task according to the topic study method was limited to a total working time of 120 minutes in two sessions. Before and after the treatment, a test of proof competency was administered to the participating students. The items of this test were linked to levels of competency requiring basic knowledge (I), simple argumentation (II) and more complex argumentation (III). Pre- and post-test were different. The post-test was designed to be more difficult, as more demanding items were included. The post-test contained an additional subtest of conceptual knowledge on generating proofs (referring to the model of the proving process by Boero, 1999).

In the second study, 153 university students (135 female, 7 male, 11 not specified) were assigned to 4 groups parallelised according to their proof competency and also according to motivational variables measured in the pre-test: A first group without a specific training (control group “unspecific treatment”,  $N_1=24$ ), a second group solving geometry tasks without proving (control group “geometry knowledge”,  $N_2=22$ ), a third group writing topic studies on mathematical proof ( $N_3=18$ ) and a fourth group learning from heuristic worked-out examples (reference group,  $N_4=89$ ).

## RESULTS

### First Study

The proof competency scores in pre- and post-test of the first study are shown in Table 1. The results reflect that the post-test (total mean score: 38.2 % of the available points; fit to a normal distribution: Kolmogorov-Smirnov-Z = 0.905,  $p = 0.386$ ) was empirically more difficult than the pre-test (total mean score: 57.3 %, Kolmogorov-Smirnov-Z = 1.139,  $p = 0.149$ ). This was expected according to the design of the post-test which contained more demanding items.

As there was no control group in the first study, it can be deduced from these results that the writing task had been able to foster proof competency in a way comparable to

the reference learning environment. Additional analyses (e.g. of parallelised items, cf. Kuntze, 2006a) suggest that the students in both groups progressed in their proof competency. However, a direct comparison to a control group can contribute to a better understanding of how the writing task in the topic study method can foster proof competency - a comparison which is provided by the second study.

Learning environment (percentages of total score)		pre-test	post-test
Writing task (topic study method) (N=121)	M	58.4	38.5
	SD	16.7	15.0
Heuristic worked-out examples (N=111)	M	56.1	37.9
	SD	17.8	15.3
Total (N=232)	M	57.3	38.2
	SD	17.2	15.1

Table 1. Results (first study): proof competency in pre- and post-test. There are no significant differences between the two experimental groups, namely the group of students writing topic studies and the reference group. On average, the students in both groups showed similar developments of their proof competency.

## Second Study

In the second study, a group of students who wrote topic studies on argumentation and proof could be compared to a control group with an unspecific treatment, to a second control group working with geometry tasks (not including proof tasks) and to a third (reference) group learning with heuristic worked-out examples. Some key results of the second study are displayed in Figure 1.

The groups being parallelised, there was no significant difference with respect to proof competency between the groups in the pre-test. In contrast, in the post-test, the group of students having worked on the writing task in the topic study scored significantly better compared to both of the control groups (control group with unspecific training:  $T=1.70$ ;  $df=40$ ;  $p<0.05$ ;  $d=0.52$ ; control group working on geometry tasks:  $T=2.14$ ;  $df=38$ ;  $p<0.05$ ;  $d=0.68$ ). The results indicate a medium effect.

Moreover, the post-test included items related to the conceptual knowledge of the students on generating proofs. The differences in the conceptual knowledge shown in Figure 1 on the right hand side are highly significant as far as comparisons with the control groups are concerned (control group with unspecific training:  $T=4.02$ ;  $df=40$ ;  $p<0.001$ ;  $d=1.24$ ; control group working on geometry tasks:  $T=3.19$ ;  $df=38$ ;  $p<0.01$ ;  $d=1.02$ ). The effect sizes show that this is a strong effect.

Similar to the first study, for the data presented in Figure 1 there is no significant difference comparing the writing task treatment to the reference learning environment of the heuristic worked-out examples.

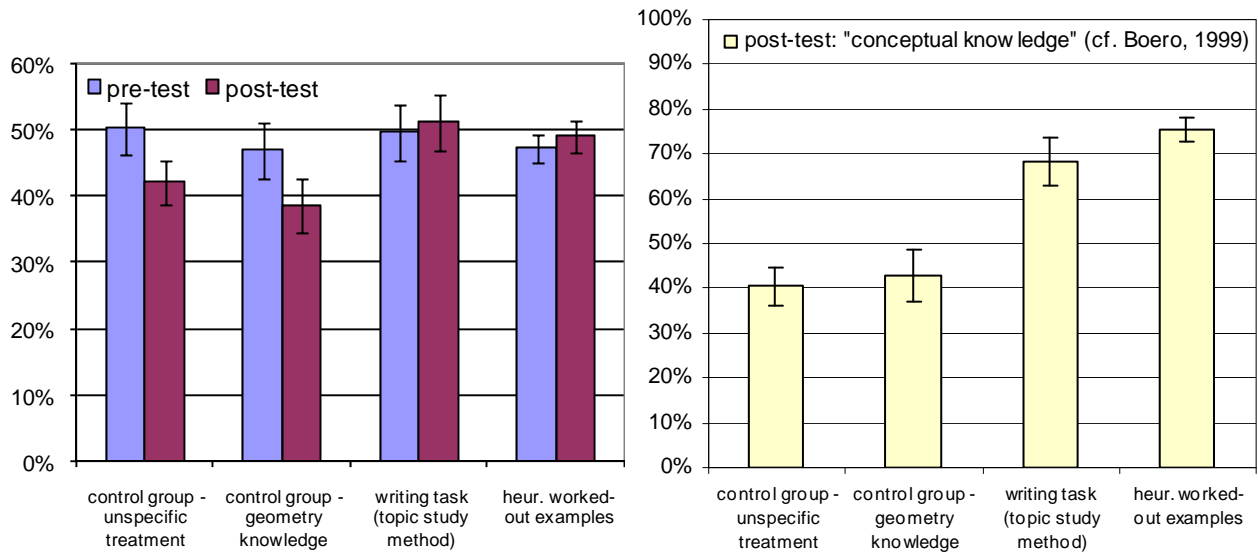

Figure 1. Results (second study): proof competency (pre- and post-test) and conceptual knowledge on generating proofs (measured only in post-test).

Additional insight is provided by the scores on the levels of competency (cf. Table 2). However, given a rather low number of 2 or 3 items per competency level in this study, the results should be interpreted with care.

Learning environment (percentages of total score)		Pre-test: Level of competency			Post-test: Level of competency		
		I	II	III	I	II	III
Control group - unspecific treatment (N=24)	M	79.2	41.0	30.6	64.6	51.4	6.3
	SD	17.9	28.6	23.9	26.5	24.5	15.2
Control group - geometry knowledge (N=22)	M	68.2	42.4	30.3	61.4	40.9	12.5
	SD	22.4	35.2	25.5	25.3	26.6	22.8
Writing task (topic study method) (N=18)	M	69.4	47.2	32.4	64.6	59.3	26.4
	SD	22.3	33.9	21.0	28.7	21.6	26.4
Heuristic worked-out examples (N=89)	M	69.3	42.5	30.2	57.6	57.5	28.1
	SD	19.4	34.6	24.0	28.8	30.9	31.5
Total (N=153)	M	70.7	42.8	30.5	60.0	54.4	22.2
	SD	20.1	33.5	23.6	27.9	28.8	28.9

Table 2. Results (second study): proof competency in pre- and post-test

Considering the levels of competency, there were no significant differences between the groups in the pre-test. In the post-test, the students having written topic studies about proving scored on average better than the control group with geometry tasks on the level of competency II ( $T=2.36$ ;  $df=38$ ;  $p<0.05$ ;  $d=0.76$ ) and better than both control groups on the level of competency III (control group with unspecific training:  $T=3.12$ ;  $df=25.3$ ;  $p<0.01$ ;  $d=0.94$ ; control group with geometry tasks:  $T=1.79$ ;  $df=38$ ;  $p<0.05$ ;  $d=0.56$ ), again showing medium or strong effects. There is no significant difference on the lowest level of competency.

Comparing the writing task group to the reference group learning with heuristic worked-out examples, no significant difference for levels of competency has been observed.

## DISCUSSION

The results suggest consistently, that writing on mathematical proving in the topic study method can foster the competency of solving geometrical proof tasks at least similarly well as the student-centred training of proof tasks offered in the reference learning environment. This can be considered as a replication of the results of Herrick (2005) for the special area of proving in geometry.

Against the theoretical background of proving in the geometry classroom, the results support the assertion that treatments focusing on proof-related meta-knowledge can have effects comparable to proof task trainings. This underlines the significance of meta-knowledge for proof competency and its development. Conversely, lacking meta-knowledge on argumentation and proof not only appears to be a key obstacle for succeeding in generating proofs, but it also seems possible to strengthen the learners' knowledge in this domain by reflections on proof, which can be encouraged by writing activities.

## References

- Boero, P. (1999). Argumentation and mathematical proof: a complex, productive, unavoidable relationship in mathematics and mathematics education. *International Newsletter on the Teaching and Learning of Mathematical Proof*, 7/8.
- Hanna, G. (2000). Proof, Explanation and Exploration: An Overview. *Educational Studies in Mathematics*, 44, 5-23. Kluwer Academic Publishers.
- Healy, L. & Hoyles, C. (1998). *Justifying and Proving in School Mathematics*. Technical Report on the Nationwide Survey. Mathematical Science. London: Institute of Education, University of London.
- Heinze, A. & Reiss, K. (2003). Reasoning and Proof: Methodological Knowledge as a Component of Proof Competence. Proceedings of the CERME 3, Bellaria, Italien. <http://www.lettredelapreuve.it/CERME3Papers/Heinze-paper1.pdf> [retrieved 04.05.2005]
- Heinze, A., Reiss, K., & Groß, C. (2006). Learning to prove with heuristic worked-out examples. In J. Novotná, H. Moraová, M. Krátká, & N. Stehlíková (Eds.). *Proceedings of the 30<sup>th</sup> Conference of the International Group for the Psychology of Mathematics Education*, Vol. 3 (pp. 273-280). Prague: PME.
- Herrick, C. J. (2005). *Writing in the Secondary Mathematics Classroom: Research and Resources*. Courtland: State University of New York College.
- Hilbert, T. S., Renkl, A., Kessler, S., & Reiss, K. (in press). Learning to prove in geometry: Learning from heuristic examples and how it can be supported. *Learning and Instruction*.
- Kuntze, S. (2005). „Wozu muss man denn das beweisen?“ Vorstellungen zu Funktionen des Beweisens in Texten von Schülerinnen und Schülern der 8. Jahrgangsstufe. [“What do we have to prove this for?” Perceptions of functions of proving in texts written by year 8 students]. *Mathematica Didactica*, 28(2), 48-70.

- Kuntze, S. (2006a). Themenstudienarbeit. [Topic Study Method]. [Doctoral dissertation]. München: Ludwig-Maximilians-Universität.
- Kuntze, S. (2006b). Teachers' beliefs on teacher training contents and related characteristics of implementation - the example of introducing the topic study method in mathematics classrooms. *Zentralblatt für Didaktik der Mathematik (ZDM)*, 38(6), 456-463.
- Lin, F.L. (2000). An approach for developing well-tested, validated research of mathematics learning and teaching. In T. Nakahara & M. Koyama (Eds.), *Proceedings of the 24<sup>th</sup> Conference of the International Group for the Psychology of Mathematics Education*, (Vol. 1, pp. 84-88). Hiroshima: PME.
- Morgan, C. (2001). The place of pupil writing in learning, teaching and assessing mathematics. In P. Gates (Ed.), *Issues in Mathematics Teaching* (pp. 232-244). London: Routledge Falmer.
- National Council of Teachers of Mathematics (NCTM). (Ed.). (2000). *Principles and Standards for School Mathematics*. Reston, VA: NCTM.
- Reiss, K., Klieme, E., & Heinze, A. (2001). Prerequisites for the understanding of proofs in the geometry classroom. In M. van den Heuvel-Panhuizen (Ed.), *Proceedings of the 25<sup>th</sup> Conference of the International Group for the Psychology of Mathematics Education* (Vol. 4, pp. 97-104). Utrecht: PME.
- Reiss, K., Hellmich, F., & Reiss, M. (2002). Reasoning and proof in geometry: Prerequisites of knowledge acquisition in secondary school students. In A. Cockburn & E. Nardi (Eds.), *Proceedings of the 26th Conference of the International Group for the Psychology of Mathematics Education*, Vol. 4 (pp. 113-120). Norwich, UK: University.
- Reiss, K. & Renkl, A. (2002). Learning to Prove: The Idea of Heuristic Examples. *Zentralblatt für Didaktik der Mathematik (ZDM)*, 34(1), 29-35.
- Selden, A. & Selden, J. (1999). Can you tell me whether this is a proof? In O. Zavalavsky (Ed.), *Proceedings of the 23rd Conference of the International Group for the Psychology of Mathematics Education*, Vol. 1 (p. 364). Haifa: PME.
- Stylianides, G. J. & Stylianides, A. J. (2006). Making proof central to pre-high school mathematics is an appropriate instructional goal: Provable, refutable, or undecidable proposition? In J. Novotná, H. Moraová, M. Krátká, & N. Stehlíková (Eds.), *Proceedings of the 30th Conference of the International Group for the Psychology of Mathematics Education*, Vol. 5 (pp. 209-216). Prague: PME.
- De Villiers, M. (1990). The role and function of proof in mathematics. *Pythagoras*, 24, 17-24.

# MATHEMATICS CONSTRUCTIONS IN AN INTERACTIVE CLASSROOM CONTEXT

Paul Ngee-Kiong Lau and Tee-Yong Hwa

Universiti Teknologi MARA Sarawak

*This study is predominantly qualitative and was guided by a naturalistic inquiry and an action research philosophy. One of the research questions was: What types of interactions between teachers and students are most productive for mathematics learning in the classroom? Five different types of interactions, mostly in the form of suggestions and questions, were identified. These were offering clarifications related to an activity, inviting students' participation, maintaining students' focus on an activity, reinforcing key features of an activity and evaluating students' understanding. Even though there was no concrete evidence of an effect of such interactions on students' academic achievement, there were plentiful of evidence on non-academic achievements such as thinking and verbalizing skills.*

## INTRODUCTION

In the last few decades, there had been an upsurge of interest on instructions that focus on the social aspect of teaching and learning. Educators realize that the social context of teaching and learning has the potential to enhance the construction process of mathematics meanings in students. On one hand, teaching could be viewed as an activity in which teachers act as guides for students' constructive processes towards, not only the taken-as-shared mathematical meanings, but also the mathematical ways of knowing. On the other hand, learning could also be viewed as an active, constructive activity in which students wrestle through barriers that arise as they participate in the mathematical practices in the classrooms. Such a view emphasizes that the teaching and learning process is interactive in nature and involves the negotiation of mathematical meanings (Cobb, Yackel, & Wood, 1992).

One of the crucial aspects to focus is dialogue. How teachers and students talk with one another constitutes in large measure such practices. According to Martin (1985):

A good [dialogue] is neither a fight nor a contest. Circular in nature, cooperative in manner and constructive in intent, it is an interchange of ideas by those who see themselves not as adversaries but as human beings come together to talk and listen and learn from one another (p. 10).

Teachers who intend to give their students the authentic problem-solving experiences in mathematics need to help them talk like expert mathematicians. Students will then be engaged constructively in mathematical discussions while solving problems by proposing, formulating, conjecturing, and justifying mathematical ideas, and be evaluating the mathematical ideas of their peers (Richards, 1991). This paper reports part of a much larger study which investigated the impact of social interactions on

students' learning. Specifically, this part addressed the research question: What types of interactions between teachers and students are most productive for mathematics learning in the classroom?

## **VYGOTSKY'S ZONE OF PROXIMAL DEVELOPMENT**

It is generally accepted that the Vygotskian School of thought probably has the most profound influence on the formation of many socio-cultural theories (Sfard, Forman, & Kieran, 2001, Forman, 2003). Vygotsky emphasizes concept formation as a major issue in the cognitive development of a child. The process of concept formation should be studied by referring to the means by which the operation is accomplished, including the use of tools, the mobilization of the appropriate means and the means by which people learn to organize and direct their behaviour. Based on this, Vygotsky (1978) conceptualizes the idea of the zone of proximal development (ZPD). He says that children who by themselves are able to perform a task at a particular cognitive level, in cooperation with adults or more capable peers will be able to perform at a higher level, and this difference between the two levels is the child's ZPD. He also claims:

Every function in the child's cultural development appears twice ... First, on the social and later on the psychological level; first, between people as an interpsychological category and then inside the child as an intrapsychological category (p. 128).

The process by which the social category performed externally transforms to the psychological category executed internally is called internalization. This internalization occurs within the ZPD since the social interaction may awaken mental functions lying in embryonic stage. Vygotsky's theory has then been applied to educational research on how children learn through interaction with others (Wood, Bruner, & Ross, 1976, Greenfield, 1984, Stone, 1993, Goos, 2004). Similarly, the ZPD was the key theoretical framework for the study presented in this paper, where the main factors were drawn guiding the analysis of data collected.

### **Teacher-Student Interaction**

The factor of interest for this paper is teacher-student interaction. It is drawn based on the distance between the cognitive levels when a child performs a task alone and in cooperation with adults. Wood, Bruner, & Ross (1976) were the first to study this aspect of the ZPD. They believe that the acquisition of skills by a child is an activity in which the readily relevant skills are combined to meet new, more complex task requirement. This activity can only be successful through the scaffolding of a tutor.

More often than not, it involves a kind of "scaffolding" process that enables a child or novice to solve a problem, carry out a task or achieve a goal which would be beyond his unassisted effort. This scaffolding consists essentially of the adult "controlling" those elements of the task that are initially beyond the learner's capacity, thus permitting him to concentrate upon and complete only those elements that are within his range of competence (Wood, Bruner, & Ross, 1976, p. 90).

Since then, the term scaffolding was associated with interactions where a teacher structured tasks to facilitate students' learning that would be beyond their reach. Greenfield (1984) defines the scaffolding process in a learning situation as:

... the teacher's selective intervention provides a supportive tool for the learner, which extends his or her skills, thereby allowing the learner successfully to accomplish a task not otherwise possible. Put another way, the teacher structures an interaction by building on what he or she knows the learner can do. Scaffolding thus closes the gap between task requirement and the skill level of the learner (p. 118).

This first phase of Vygotskian-inspired studies were criticised for the imposition of a structure on the learner. The metaphor implied by scaffolding rests on the question of who is constructing the structure. Too often, the teacher is the builder and the learner is expected to accept a predetermined structure. Searle (1984) says:

The children's understanding, valuing and excitement for the personal experiences were negated as the children were led to report the experience in an appropriate form (p. 481).

Stone (1993) suggests that a learner is continually trying to interpret the adult's intervention, whether verbal or non-verbal in the context relevant to him. Unless the adult and the learner have a shared context at that point, the implications of the intervention will not be realized. Since then, the second phase of such studies recognizes the need to give attention to the context and the interpersonal relationship of social interactions (Forman, 2003, Goos, 2004).

## **METHODOLOGY**

This study was predominantly qualitative. The methodology was formulated through incorporating features of naturalistic inquiry and the spiral nature, interventional and group work of action research (Lincoln and Guba, 1985, Kemmis & McTaggart, 1988). Two teachers from a secondary school accepted the invitation to participate in this study. Both teachers are qualified teachers and have many years' experience in teaching secondary school mathematics. The study was conducted on two classes of Form Four students aged between 16 and 17 years old in the school.

The field work of the study consisted of observing the teachers and students in the classrooms and discussing the work with them. Three formal methods of data collection were used: video recording of the lessons, running records of observations and informal discussions, and audio taping of the interviews with teachers and students. These tapes were transcribed and the transcriptions consisted of the time, the sequential conversation of the participants and non-verbal events, which could assist in interpreting the interactions between the participants.

The study also entailed the development of a framework that represents the amalgamation of the work of educators such as Schoenfeld (1983), Cobb and Whitenack (1996), and Creswell (2003). There were three phases in the analysis of the data. The first phase was initial analysis by organizing, reading and coding the data into the main factors drawn from the ZPD. Then, the researchers performed episode-by-episode analyses to come up with smaller themes for each factor. Finally,



comparative analysis was done to come up with the interpretations and conclusions for each theme.

## RESULTS AND DISCUSSIONS

This section presents the results and discussions pertaining to the research question “What types of interactions between teachers and students are most productive for mathematics learning in the classrooms?” of the study.

### Four-Phase Lesson Plan

Implicit in the ZPD is the emphasis of active participation of the learner in the collaborating process. However, the large number of students in a class is a problem for a teacher to interact for sustained time with each individual student. This task is further complicated with students of different abilities having different zones of proximal development. Hence, the researchers and the teachers in this study adopted a four-phase lesson plan to ensure active participation of students.

During the first phase, the teachers held whole-class discussions in which they facilitated students to understand a problem and to come up with possible heuristics and strategies for a solution. Group work was the second phase that provided a chance for students to solve a problem themselves through active discussions. Many educators share the same view that group work provides the right condition for the free exchange of ideas and reciprocal feedback between mutually respected equals when tackling a task (Damon, 1984). At the third reporting-back phase, students were given an opportunity to explain and justify their solutions to the class. As any solution represented the collective result of a group, this boosted their confidence in delivering the solution to the class. The final phase was the teacher summing up the lesson by actively discussing all solutions, justifying the legitimacy of each solution, introducing new symbols and mathematical language, and extending the problem.

### Teacher-Student Interaction

The analysis of data collected yielded five different types of productive teacher-student interactions that could not only foster the development of students’ conceptual understanding, but also enhanced their awareness of the strategies and thinking dispositions required in problem solving.

The first type is offering clarification. These interactions usually occurred during the whole-class discussions and the reporting-back phase. The main aim was to get the students to understand the activity thoroughly, to generate possible strategies for a solution and to amplify students’ explanations. In one of the lessons, students were working on the figure below to find  $\angle DAB$ . The following is part of the transcription of the reporting-back phase.

Teacher: What is the answer?

Jane:  $\tan \angle DAB = 6/8$ .  $\angle DAB = 36.9^\circ$ .

Josh: Why do we use tan?

Why don't we use sin or cos?

Teacher: That's a good question. Why?

Jane: We don't have the hypotenuse.

Teacher: Can't we find it?

Clara: Use Pythagoras theorem to find it.

Teacher: Yah. Then, we can use sin or cos. Since we can use tan for the given values, why must we waste time to find the hypotenuse?

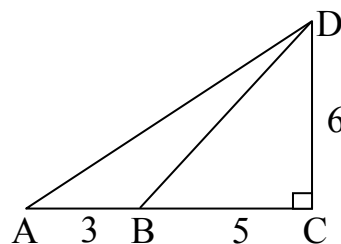

The teacher was not satisfied with the clarification 'We don't have the hypotenuse' and he offered his clarification. In the end, the students noticed that they could use sine or cosine instead of tangent through finding the hypotenuse first, but it would take more time for them to do so.

The second type is inviting students' participation, which usually occurred during the first three phases of a lesson, aiming to further clarify the activity or doubts, to involve students actively in their learning and to get students to justify their solutions. For instance, the teacher invited students to participate in group discussion for a solution in one of the lessons by saying:

Teacher: You're given the handout Work with your friends ... Can you do it? After this, I'll ask some of you to share your solution with the class.

During the reporting back phase:

Teacher: Is there any other method? I see one student putting up his hand.

John: (Writing his solution on the board)

Teacher: OK. This is the 1st method, we can also use. This is the 2nd method.

Ali: Why do we use  $\frac{1}{2}r^2\sin\theta$  and not  $\frac{1}{2}\times\text{base}\times\text{height}$ ?

Teacher: Jane, can you draw the height of the triangle POQ?

Teacher: Now, express  $h$  in terms of  $\theta$ .

Jane:  $\sin\theta = h/16$ ,  $h = 16\sin\theta$ .

Teacher: What do you get for the area by using this?

Ali: It's the same.

Teacher: Good. Can you use both formulas? Give him a clap.

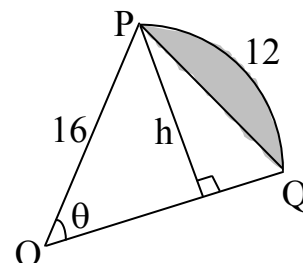

Through this interaction, not only Jane, but the other students in the class understood that  $\frac{1}{2}r^2\sin\theta$  is derived from  $\frac{1}{2}\times\text{base}\times\text{height}$ . This is important if we want students to become active participants in the teaching and learning process. By doing so, students will have a meaningful personal connection with their teachers and peers in the classroom. Then, emotional achievement will go hand-in-hand with cognitive achievement, enabling them to acquire not only the content knowledge, but also the individual and social skills for successful engagements in subsequent lessons.

The third type is maintaining students' focus on the activity in hand. The two students below were engaged in off-task talk.

Josh: (Playing with his pen) I slept late last night.

Dane: Where have you been?  
 Josh: We went for a movie. Oh, I hate doing this.  
 Dane: You can't, we're in front of the camera.  
 Teacher: Josh, have you got the answer?  
 Josh: I can't understand the question.  
 Teacher: Read the question (And Josh reading it).  
 Teacher: What should we do first?

The teachers decided to constantly remind the students of their work, attend to them and ask them questions related to the task when they sensed that the students were off-task. Hence, such interactions mostly occurred during group work to keep students on-task and on-track to a solution.

The fourth type is reinforcing or accentuating key features of the activity in hand. In any lesson, the teachers constantly monitored students' progress in their problem-solving activity. They would immediately help students who misunderstood or lacked understanding in any activity. Hence, such interactions occurred throughout the lesson to emphasize important features of the activity to increase students' success in solving it. These features included content knowledge, strategies to solve the activity and the thinking skills. In one of the lessons, students were asked to work on the problem: "In the diagram, ABCD is a straight line. Given that  $CE = 3EF = \frac{1}{2}BD$ , find the value of  $\cos y$ ." The following is the transcription of a part of the lesson.

Teacher: Read the question.  $CE = 3EF$ , what does this mean?  
 Ahmad: The length of CE is three times that of EF.  
 Teacher: Then  $3EF = \frac{1}{2}BD$ . How do we use this?  
 Ahmad: Correct.  $\frac{1}{2}BD = 3EF$ . Now, we've 4EF, 3EF and 5EF. We use Pythagoras theorem.  
 Jane: How do we find  $\cos y$ ?

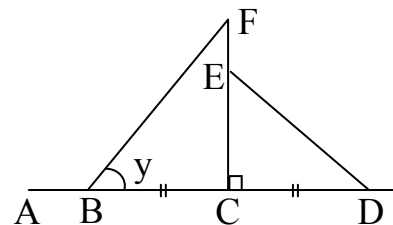

Ahmad: ...  $CE = 3EF$ .  $3+1 = 4$ . So,  $CF = 4EF$ .  $3EF = \frac{1}{2}BD = BC$ . The sides of the triangle are 3, 4 and 5 by using Pythagoras theorem.

The questions posed by the teacher probed Ahmad to orchestrate the key feature  $CE = 3EF = \frac{1}{2}BD$  into useful information to help them solving the activity successfully.

The last is evaluating students' understandings. The teachers would consistently evaluate students' emerging understandings from their solutions of the activity. If the emerging understandings were satisfactory, the teachers would verify the students' solutions. Otherwise, they would immediately intervene to help the students. Hence, such interactions usually occurred during the last two phases of a lesson, reporting back and summing up, to legitimize students' solutions. The following is part of the transcription of the interaction between the teacher and two students working together on the problem: "Given  $QS = RP$ , find the perimeter of the shaded region." These students had the following solution.

$$S = r\theta, \theta = S/r = 8/4 = 2 \text{ rad.}$$

$$QS = RP = 2. PQ = 8 \text{ cm. RS} = 6(2) = 12 \text{ cm.}$$

$$\text{Perimeter} = 2^2 \text{ cm} + 8 \text{ cm} + 12 \text{ cm} = 24 \text{ cm.}$$

Teacher: where do you get 22?

Joe:  $2 + 2$ .

Teacher: Is  $2 + 2 = 22$ ?

Kate: The answer is the same, but it's unsuitable.

Teacher: Yes. It's true for 2 only. If you don't believe, is  $3 + 3 = 32$ ?

Joe: No.

Teacher: So, we must write  $2 + 2$ .

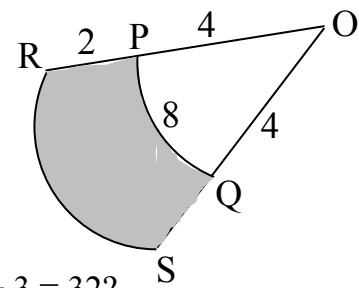

The teacher helped the students to rectify the error by giving another example to help them realize that  $(QS + RP)$  should not be written as  $2^2$ .

### Non-Academic Achievement

As the study progressed, the students changed from passive receivers of knowledge to active self-regulators of their learning. Students started questioning, explaining, forwarding opinions and rectifying their unsatisfactory emerging understandings. They put forward questions and suggestions to their teachers or during group work like “Can we use ...? Do we use ...? Why? Why do we use ...? Why don't we use ...? How do you ...?” as evidenced in those transcriptions given above. These questions and suggestions were quite similar to the questions and suggestions posed by their teachers to them. Hence, the students had internalized some of the questions and suggestions of the teachers to become their own stock of tools for questioning.

One student said: ... before this, I don't know how to start answering a word problem. Now, I start looking for information contained in it and ask a lot of questions. As a result, I am able to think of different methods to solve it before I choose one to answer it.

The teachers also found that they could lead students to explain satisfactorily their ‘brief’ or ‘disconnected’ responses. This placed the teachers under the obligation of approaching the students’ solutions in a non-evaluative way and to refrain from imposing their ways of tackling an activity on their students. As the students realized that their explanations or solutions were respected and accepted, they felt obliged and were very willing to share their solutions. As the study progressed, the responses from students slowly evolved to explanations which ‘made sense’ to anybody.

Another student said: Even though my marks haven't improved much, I understand concepts better now. And I'm enjoying it ... I understand it and I'm asking a lot of questions. Even if I don't get the final answer right, I always know where's wrong.

### CONCLUSION

A four-phase lesson plan consisting of whole-class discussion, group work, reporting back and summing up was adopted to ensure active participation from students in the teaching and learning process. Five different types of teacher-student interactions that

were very productive to students' learning, mostly in the forms of suggestions and questions, were identified - offering clarifications related to an activity, inviting students' participation, maintaining students' focus on an activity, reinforcing key features of an activity and evaluating students' understanding. There were plentiful of concrete evidence on students' non-academic achievements such as thinking and verbalizing skills.

## References

- Cobb, P., Yackel, E., & Wood, T. (1992). A constructivist alternative of the representational view of mind in mathematics education. *Journal for Research in Mathematics Education*, 23(1), 2-33.
- Cobb, P. & Whitenack, W. (1996). A method for conducting longitudinal analyses of classroom video-recordings and transcripts. *Educational Studies in Mathematics*, 30, 213-228.
- Creswell, J. W. (2003). *Research Design*. London: Sage.
- Damon, W. (1984). Peer Education: The Untapped Potential. *Journal of Applied Developmental Psychology*, 3, pp. 331 - 343.
- Forman, E. A (2003). A sociocultural approach to mathematics reform: Speaking, inscribing and doing mathematics within communities of practice. In J. Kilpatrick, W. G. Martin, & D. Schifter (Eds.), *A Research Companion to Principles and Standards for School Mathematics*, pp. 333 - 352. Reston, VA: NCTM.
- Goos, M. (2004). Learning mathematics in a classroom community of inquiry. *Journal for Research in Mathematics Education*, 35(4), 258 - 291.
- Greenfield, P. M. (1984). A Theory of the Teacher in the Learning Activities of Everyday Life. In B. Rogoff & J. Lave (Eds.), *Everyday Cognition: Its Development in Everyday Context*. Cambridge, MA: Harvard University Press.
- Kemmis, S. & McTaggart, R. (1988). *The Action Research Planner*. Geelong, Victoria: Deakin University Press.
- Lincoln, Y. & Guba, E. (1985). *Naturalistic Inquiry*. BeverleyHills: Sage.
- Martin, J. (1985). *Reclaiming a Conversation: The Ideal of the Educated Woman*. New Haven, CT: Yale University Press.
- Richards, J. (1991). Mathematical Discussions. In E. von Glaserfeld (Ed.), *Radical Constructivism in Mathematics Education*, pp. 13 - 51. Dordrecht, The Netherlands:Kluwer.
- Searle, D. (1984). Scaffolding: Who's building whose building? *Language Arts*, 61(5), 480-483.
- Scheonfeld, A. H. (1983). Episodes and executive decisions in mathematics problem solving. In R. Lesh & M. Landau (Eds.), *Acquisition of Mathematics Concepts and Processes*, pp. 345 - 395. NY: Academic Press.
- Stone, C. A. (1993). What is missing in the metaphor of scaffolding? In C. A. Stone, N. Minick, & E. A. Forman (Eds.), *Context for Learning: Sociocultural Dynamics in Children Development*, pp. 169 - 183. NY: University Press.
- Vygotsky, L. (1978). *Mind in Society: The Development of Higher Psychological Processes*. Cambridge, MA: Harvard University Press.
- Wood, D., Bruner, J. S., & Ross, G. (1976). The Role of Tutoring in Problem Solving. *Journal of Child Psychology and Psychiatry* 17, 89 - 100.

# THE PROBLEM SOLVING MAP METHOD: A TOOL FOR MATHEMATICAL PROBLEM SOLVING

Henry Leppäaho

University of Jyväskylä

*This research paper focuses on how a novel problem solving strategy, the problem solving map (PSM) method, was taught to pupils and how they learn and use it in practice. The intention of the PSM method is to support pupils in looking for the route toward the solution. Teaching intervention was carried out during a period of six weeks. The PSM method was used in teaching the experimental group in fifteen lessons during normal school days at grade 6. The experimental group (n=17) and the control group (n=35) took part in a pre-test, post-test and 18 months later in a delayed test. The results of the tests indicated that the PSM method could be useful for teaching and learning mathematical problem solving.*

## INTRODUCTION

Problem solving strategy is a previously learnt way to solve problems (see e.g. Schoenfeld 1985, 109-110). These strategies can be learnt and practised using examples. But when pupils encounter a new problem, they have to find out themselves what kind of strategy can be applied in solving a specific problem. It is difficult to teach this skill, but pupils can be guided to choose a possible way to start and this, in turn, helps them to control their uncertainty. The PSM method is a functional problem solving strategy. The intention of PSM is that the pupil will learn to create a map of his/her solving process through writings and drawings.

In spite of good solving strategies it happens fairly often that solvers cannot solve the new problem, with the result that they feel uncertainty and failure. Schoenfeld (1992) has also concluded that the prescriptive use of heuristics is not particularly helpful for improving problem solving performance or its transfer to a new situation.

From another perspective, however, it is useful to teach problem solving strategies. Pupils need examples of strategies in order to learn to apply procedures to new problems. Therefore, practising problem solving strategies has the potential to serve as a powerful descriptor of problem solving behaviour (Schoenfeld, 1992). In this way pupils' uncertainty can be reduced and their attitude towards mathematical problem solving may improve.

Everyone sometimes makes mistakes in mathematics and it is part of studying mathematics. Skilful mathematicians also make numerous attempts when they try to solve difficult problems (Stylianou 2002). Unfortunately, the attitude of many teachers towards pupils' wrong answers is negative. Awareness that wrong answers are accepted as a step towards the right answer may help pupils to try different kinds of attempts to solve the problem. One basic idea of the PSM method is that wrong answers are also a part of studying problem solving and mathematics. In practice this

becomes clear in giving instructions for the PSM method: *You may not delete your wrong solution, but you can make a new attempt to modify your solution afterwards.*

The PSM method stresses the importance of pupils' writing. According to Morgan (2001) writing has some useful characteristics that are not shared with spoken language, for example: 1) During the writing process, writers can look back at what they have already written, reflect on whether it really transmits the intention, revise and redraft it. 2) The writer generally has more time to think about what they are writing and hence to clarify and refine their thinking. 3) Writing and mathematics are similar activities. The processes of writing and mathematical problem solving are similar, as both of them involve recursive development of clarity about the nature of the problem and its solution. Pugalee (2004) has also compared writing and the verbal (talk aloud) description of the mathematical problem solving process. He noticed that problem solving and writing have a better connection to the right answers than problem solving and verbal expression. Students who wrote descriptions of their thinking were significantly more successful in problem solving tasks than students who verbalized their thinking.

### **The problem solving map (PSM) method**

It is widely known that hypothesis and testing form the cycle of a problem solving model (e.g, Mason, Burton, & Stacey 1982; Schoenfeld 1985). Already Pólya (1948) has given systematic instructions on how to solve a problem.

First of all, pupils have to perceive and understand the problem in order to extract from it the relevant information. It is necessary to keep the information in the working memory so that they can try different approaches in their mind in order to make a plan before they can move on to the next step, the actual solving process, i.e. carrying out the plan. At first pupils need systematic guidance with one problem solving strategy in order to be able to manage in problem solving. Therefore, in this study pupils were first introduced to the use of a problem solving map (PSM) as a helping tool.

The main idea of the PSM method is that pupils will learn to collect notes that will help to solve the problem. Thus, the PSM acts as a map to support pupils when they look for the route toward the solution and they can always come back and check the stages they have passed through in their attempt to solve the problem. The PSM method emphasizes metacognitive thinking. Using PSM, the pupil tries to sketch out his own solving process on paper so that he can follow his thinking. According to Finkel (1996) the application of metacognitive techniques has two important mathematical purposes: 1) It allows pupils to keep track of what they have done and are planning to do next, and 2) It allows pupils to make connections between their problem solving work and their knowledge of subject matter and mathematical procedures.

The pupils were taught to construct PSM with the following instructions: 1) *Read the task,* 2) *Pick out information about the task and write it down,* 3) *Choose a solving*

strategy, 4) Write down your thinking and solution, 5) Always make a drawing or diagram of the task if it is possible, 6) Evaluate and check your solution, 7) If you find a lot of errors, make a new solution after the wrong solution and 8) Don't delete the wrong solution; it is part of the solving process, too!

Figure 1 shows an example of a problem solving map designed by a pupil in the experimental group. The need to construct a PSM for any problem whenever possible was emphasized.

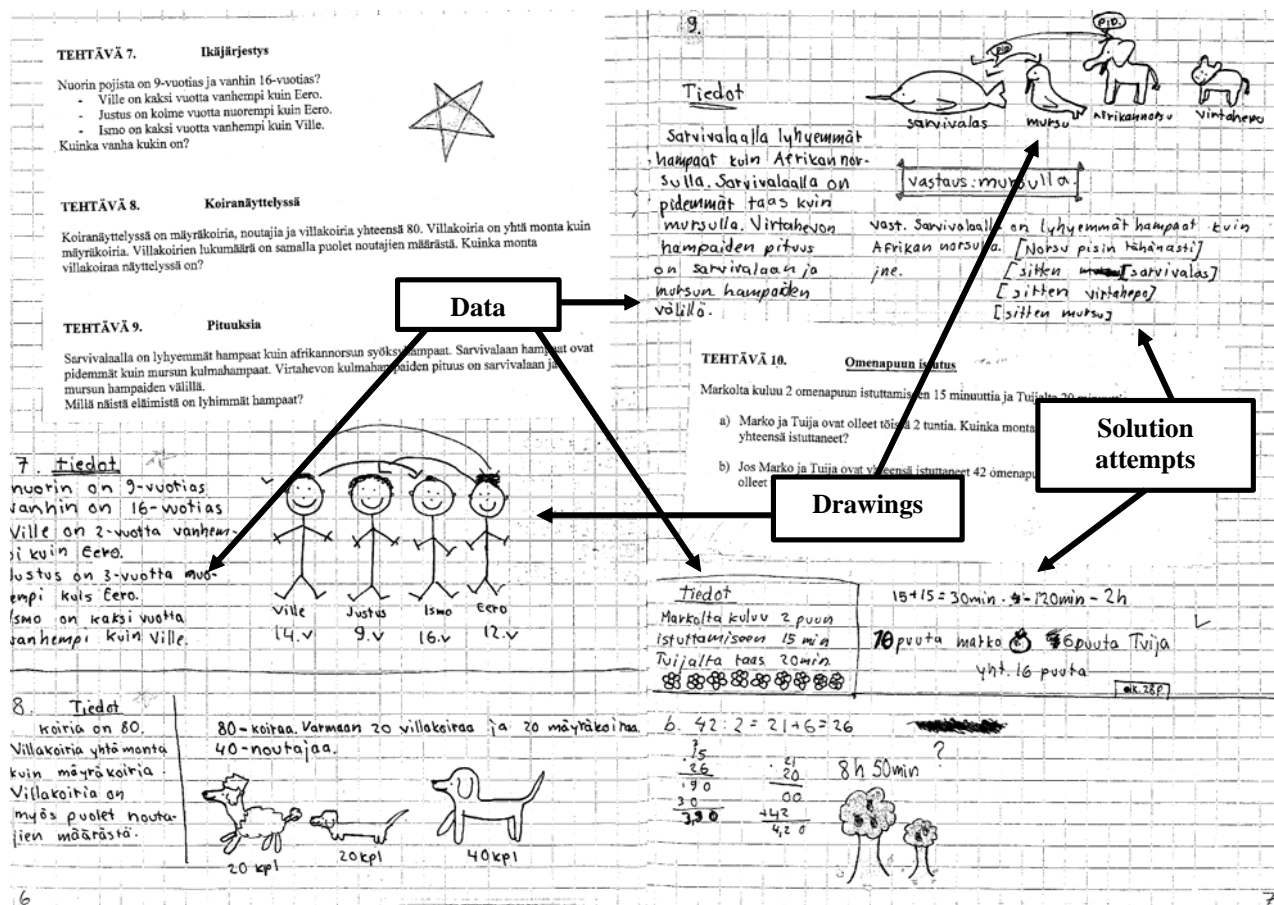

Figure 1. An example of a problem solving map.

During the teaching intervention pupils solved altogether about 30 problems using the PSM method in their notebooks. After that their notebooks were collected for analysis of how clearly they had learnt to use the PSM method in practise.

### METHOD

The whole study is based on a dissertation (Leppäaho 2007) in which the intention was to design a novel learning environment for mathematical problem solving. It was carried out in the Finnish 6th grade using qualitative and quantitative methods. This kind of study, which combines different methods, is called a *mixed methods* study (e.g. Johnson & Onwuegbuzie 2004; Lankshear & Knobel 2004). The data were collected by assessing the teaching intervention (total 30 lessons) and through a quasi-experimental design. Conclusions were drawn on the basis of triangulation of



the qualitative and quantitative results. The present paper focused on the PSM method which was dealt with in 15 lessons.

One study class of 17 pupils, the experimental group was taught the PSM method over six weeks in 15 lessons by the teacher-researcher. The lessons were integrated into their regular school days, mainly in mathematics lessons. The control group consisted of two study class with 35 pupils in total. The control group studied mathematics and problem solving in their normal way using standard mathematics textbooks.

At the beginning of the teaching intervention the pupils were given instructions (see above) on how to construct the PSM. The pupils' problem solving performance was measured in a pre-test and a post-test, both of which consisted of 14 tasks and took 90 minutes. In selecting the tasks the following criteria were set: 1) a diverse group of different problem types should be presented, 2) they should fulfil the definition of the problem i.e. they should not be routine tasks, and 3) they could be solved according to the 6th grade curriculum. The corresponding tasks were not dealt with during the lessons. The tasks in the post-test were designed on the basis of the problems in the pre-test in order to find out any changes. In some cases the numerical values were changed, in other cases the setting was changed but the structure and the type of the task was kept the same. Pupils were also requested to explain their solutions using words, equations and drawings.

In the delayed test pupils had 45 minutes to solve six problems. Pre- and post-test results gave information of tasks which separating the pupils the best. The structures of the best were chosen to the delayed test. The problems in the delayed test were slightly more demanding so the pupils also faced real problems in the delayed test.

The reliability coefficients (Cronbach's alpha) were as follows: in the pre-test 0.884, in the post-test 0.885 and in the delayed test 0.785. The tests can therefore be considered reliable.

## RESULTS

### *Case Harry*

As a typical example of a pupil in the experimental group, I present the one pupil's solutions. In this paper I have called him Harry. Figure 2 shows Harry's answers to the corresponding tasks in the pre- and post-test and in the delayed test.

In pre-test task B7 Harry has only written the wrong answer: *Wednesday*. There is no justification for the solution, so he got zero points. In post-test task D6 we can see that Harry has used the PSM method successfully. Harry has written the essential information about the task on the right-hand side of the paper, and he has designed a helpful drawing, which helps him to discover the correct solution. So, he gets full marks on this task: 2 points.

In the delayed test task E3 Harry has sketched out the right order of the drivers using the abbreviated form of the names (Figure 2). But it is not clear who is first and who is last. So, this inaccuracy lowered his score by 0.5 points.

To summarize the results on the solving of the presented tasks, it seems that Harry has learned to apply the PSM method in the exam situation in the post-test. He also uses some part of PSM method in the delayed test 18 months later: he picks out information about the task and writes it down.

An example of a pre -test problem B7:

Ville bought a cat on 13<sup>th</sup> of March. It was Thursday. What day of the week was the 1<sup>st</sup> of March?

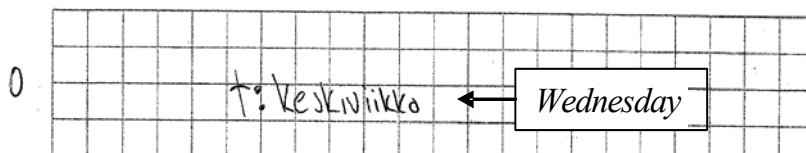

The corresponding post -test problem D6:

In the skiing competition four skiers are approaching the finishing line. The Finnish skier is leading. The Norwegian is behind the Russian. The Russian is in front of the Swede. Who is the last one?

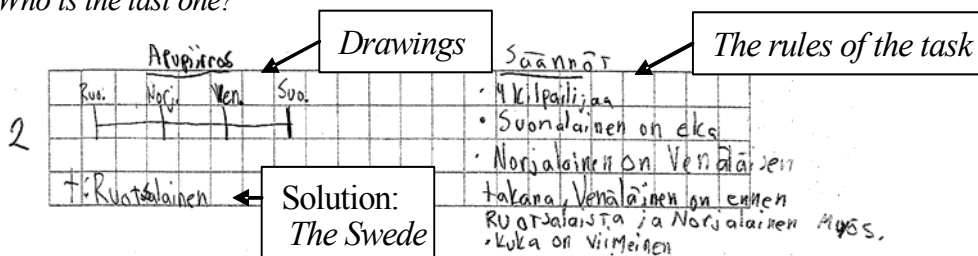

The corresponding delayed test problem E3:

In the F1 race the fastest cars are approaching the finish: Schumacher is behind Webber. Webber is ahead of Alonso. Räikkönen overtakes Webber and Alonso overtakes Coulthard. What is the order of the competitors?

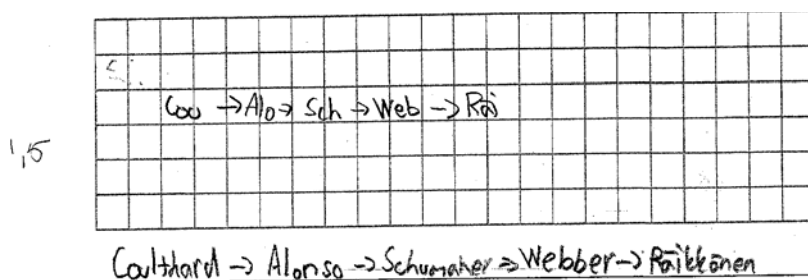

Figure 2. Harry's answer to one equivalent task in the pre- and post-test and in the delayed test.

*The total results of the experimental group and the control group*

The results of the pre-test, post-test and delayed test are shown in table 1. In the pre-test there are no significant or effect size differences between the groups. The control group's average scores were only slightly better than those of the experimental group. The improvement of the whole experimental group compared to the control group in the total scores between the pre- and post-test was significant (analysis of variance  $p = 0.000$ ;  $F = 26.63$ ;  $df = 1$ ).

Total scores	Pre-test	Post-test	Delayed test
Experimental group (N = 17)	32.26	40.84	13.34
Control group (N = 35)	33.01	32.60	11.63
Difference between groups <i>Exp - Cont</i>	-0.75 (-2%)	+8.24*** (25%)	+1.71 (15%)
Effect Size: <i>Cohen's d</i>	-0.08	+1.02	+0.45

Effect size by Cohen's d: small d = 0.20; medium d = 0.50; large d = 0.80

\* p < 0.05; \*\* p < 0.01; \*\*\* p < 0.001

Table 1. The total scores in the pre- and post-test and delayed test

The total scores of the experimental group improved significantly in comparison to the control group between the pre- and post-test (analysis of variance  $p = 0.000$ ;  $F = 26.63$ ;  $df = 1$ ). Similarly, the effect size measured by *Cohen's d* also shows a large difference between the groups. Another important finding was that all the pupils in the experimental group improved their scores in the post-test, by a range of 2.3 to 21.3 points.

The purpose of the delayed test was to find out how stable the differences between the groups are. All the pupils were studying in different and mixed study groups at grade 7 in the same school, so that they had studied a whole school year in similar teaching and learning environments. In the delayed test (table 1) there were no significant differences between the groups, except in one of the six tasks. In the first task the experimental group was still statistically better than the control group (t-test,  $p = 0.004$ ). The effect size (0.45) exceeds the small difference limit between the total scores. But in percentage terms the difference remains in favour of the experimental group in the delayed test.

In Figure 3 the performance of the experimental group and the control group is compared when the results of the control group are standardized to 100% in all three tests. In the post-test there is a clear statistical difference in the overall results between the groups in the post-test. The experimental group was 25% better than the control group.

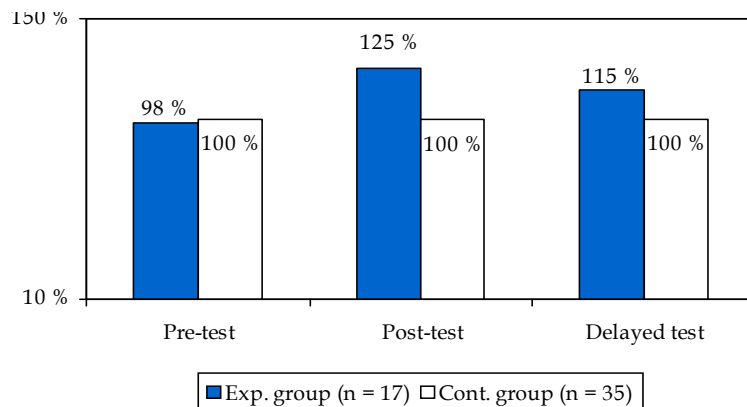

Figure 3. Percentage differences between the experimental group and the control group in the pre-, post- and delayed tests

There is no statistical difference in the overall results in the pre-test and in the delayed test. But nevertheless it is quite interesting that in percentage terms the experimental group was still 15% better in the delayed test, even if it was 2 % weaker than the control group in the pre-test.

## CONCLUSIONS

A pupil's written representations play an important part in a pupil's mathematical thinking (Hiebert & Carpenter 1992; Häikiöniemi 2006). With this kind of pupil's representations the teacher gets information on a pupil's mathematical thinking. The pre-test showed that the pupils of the control and experimental groups (for example Harry) had difficulties to expressing their thinking in mathematical language. At the end of the teaching intervention and even in the post-test situation, most of the experimental group pupils could create a PSM. A relevant observation in this study was that it is possible to teach and improve pupils' ability to use written representations in their mathematical thinking by using the PSM method. On the other hand this kind of method, which reveals a pupil's thinking, helps the teacher to see where the pupil has difficulties. The use of such a kind of systematic method as PSM in starting to work with a problem as well as the "permit" to make all kinds of attempts to find the solution probably reduces pupils' feelings of uncertainty.

The aim of the problem solving map method is to help pupils to illustrate and process mathematical problems in writing and drawing. As the results show, the pupils' performance improved. The PSM method supports the pupils' memory so that it is easier for them to go back to the basic information or to look at the drawing to see the structure of the problem.

Of course, we should treat the conclusions cautiously, because the groups are quite small and many factors might have influenced the results, as is always the case in studies of teaching and learning. Therefore a new wider study of the PSM method is planned to be carried out next year. But in this case the results suggest that using the PSM method could be a useful way to teach and learn mathematical problem solving.

## References

- Finkel, E. (1996). Making sense of genetics: Students' knowledge use during problem solving in a high school genetics class. *Journal of Research in Science Teaching*, 33(4), 345-368.
- Hiebert, J. & Carpenter, T. (1992). Learning and teaching with understanding. In D. Grouws (Ed.), *Handbook of Research on Mathematics Teaching and Learning*. New York: Macmillan, 65-97.
- Häikiöniemi, M. (2006). *The role of Representations in Learning the Derivative*. University of Jyväskylä. Department of Mathematics and Statistics. Report 104.
- Johnson, B. & Onwuegbuzie, J. (2004). Mixed methods research: A Research paradigm whose time has come. *Educational Researcher*, 33(7), 14-26.
- Lankshear, C. & Knobel, M. (2004). *A Handbook for Teacher Research: From Design to Implementation*. Maidenhead: Open University Press.

- Leppäaho, H. (2007). Matemaattisen ongelmanratkaisutaidon opettaminen peruskoulussa. Ongelmanratkaisukurssin kehittäminen ja arviointi. [Teaching mathematical problem solving skill in the Finnish comprehensive school. Designing and assessment of a problem solving course.] University of Jyväskylä. Jyväskylä Studies in Education, *Psychology and Social Research*, 298.
- Mason, J., Burton, L., & Stacey, K. (1982). *Thinking Mathematically*. Bristol: Addison-Wesley.
- Morgan, C. (2001). The place of pupil writing in learning, teaching and assessing mathematics. In P. Gates (Ed.), *Issues in Mathematics Teaching*, 232-244. London: Routledge Flamer.
- Pugalee, D. (2004). A Comparison of verbal and written descriptions of students' problem solving processes. *Educational Studies in Mathematics*, 55(1), 27-47.
- Pólya, G. (1948). *How to Solve it? A New Aspect of Mathematical Method*. Princeton, NJ: Princeton University Press.
- Schoenfeld, A. (1985). *Mathematical Problem Solving*. London: Academic Press.
- Schoenfeld, A. (1992). Learning to think mathematically: Problem solving, metacognition, and sense-making in mathematics. In D. Grouws (Ed.), *Handbook for Research on Mathematics Teaching and Learning*, 334-370. New York: Mac Millan.
- Stylianou, D. A. (2002). On the interaction of visualization and analysis: The negotiation of a visual representation in expert problem solving. *Journal of Mathematical Behavior*, 21, 303-317.

# TWO JUSTIFICATION PROCESSES IN SOLVING ALGEBRAIC PROBLEM USING GRAPHING TECHNOLOGY

Hee-Chan Lew and Kum-Nam So

Korea National University of Education

*This study investigated how two types of justification, namely empirical and deductive, are displayed in the process of solving algebraic problems using graphing technology by two Korean high school students and also the type of influence graphing technology has on the justification process. Graphing technology was found to make empirical justification possible when solving a problem in which the solution is difficult to obtain in a pencil and paper environment. Graphing technology enabled mathematical assumption through operational activities followed by immediate experimentation and corroboration and also provided a significant clue for deductive justification. The study showed that operational activities using graphing technology can be important tools in solving mathematical problem.*

## INTRODUCTION

Justification is an important theme to consider in mathematics instruction. It is a comprehensive concept that encompasses rigidly developed deductive proofs and a psychological activity that involves systematic persuasion based on one's personal point of view (Lannin, 2005; Harel & Sowder, 1998). The curricula of many countries including that of Korea emphasize on activities that allow students to independently justify mathematical facts through induction and deduction (MOEandHRD, 2007; NCTM, 2000; MOE, 1999; DOE, 1995; AES, 1994; NCTM, 1991). Many researchers in mathematics education have underscored the educational meaning of justification for a long time (Lannin, 2005; Healy & Hoyles, 2000; Harel & Sowder, 1998; Knuth & Elliott, 1998; Hoyels, 1997; Simon & Blume, 1996; Battista & Clements, 1995). However, preceding research, for the most part, focused on proving in the realm of geometry (For example, Knuth & Elliott, 1998; Harel & Sowder, 1998; Battista & Clements, 1995), and with the exclusion of just a few (For example, Healy & Hoyles, 2000), research on proving in algebra is hard to find. In addition, most cases of research deal with the types of justification showed by middle school or high school students or pre-service elementary or middle school teachers (For example, Simon & Blume, 1996). Moreover there is inadequate research on how instructional media such as computers influence the justification process, what kind of role teachers play in justification, and what kind of relation the process of justification has in solving complicated problems.

Considering this widely unexplored area, this research aims to explore the justification process in solving algebraic problem using graphic technology and the role it plays. The paper will discuss the particular features of the justification process identified in this study, and finally set forth a model for the role teachers ought to play in instructing justification in the classroom.

## METHODOLOGY

### Problem

In traditional algebraic learning, students are expected to identify regularities in the problem solving process on their own and express such regularities as equations and graphs, while the aspects of justification are not as well addressed (NCTM, 2000). In an effort to find an effective methodology to compensate such shortcomings in algebraic learning, the present research selected an algebraic problem ([Figure 1]) that focused on exploration of many regularities that occur in carrying out operational activities involving graphic technology and the justification process.

In relation to  $h(x) = f(x) g(x)$  consisting of the two linear functions  $f(x)$  and  $g(x)$ ,  $h(x)$  intercepts with  $f(x)$  and  $g(x)$  as shown below. Find the linear functions  $f(x)$  and  $g(x)$  that satisfies this condition.

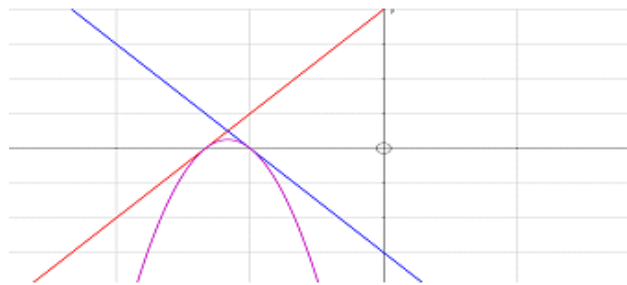

Figure 1. The algebraic problem given to students.

### Procedure

This experiment was conducted with second year high school students in the humanities track, who personally volunteered to participate in the study with reference from the students' homeroom teacher and with the consent of their parents. Two students who were above average in terms of academic achievement were selected to participate. Over the course of two weeks, three experiments were conducted. The students were asked to solve problem using computer by continuously communicating and discussing with each other. At first, the students were asked to solve the problems with paper and pencil, but when it became evident that the students could not attain a solution, they were asked to use the graphing technology. Although the students were trained on using a particular software, used two hours prior to the experiment, students could use any type of software that produced resultant graphs once functional formulae were input.

### Data Collection

The researcher played the role of teacher in the data collection process and therefore participated and observed the whole experiment process. In addition, the researcher also provided guidance for the students whenever they needed help. In the entire course of data collection, whenever deemed necessary, the researcher also carried out non-structured interviews with the students in order to clarify meanings overheard in

their communications. A video camera was used to keep a record of instruction and learning, and the computer screens that captured the students' activities and their utterances were also captured as moving pictures.

## RESULTS

### The Process of Discovering a Particular Solution by Controlling Parameters

After trying to solve a problem with paper and pencil for approximately 15 minutes, students gave up when they realized that the 4 parameters including the two functions' intercepts and slopes were convolutedly intertwined. When it was suggested that they use the computer, they fixed the intercept of  $f(x)$  to 0, input random values into the other variables and input  $f(x)=2x$ ,  $g(x)=-2x+4$ ,  $h(x)=2x(-2x+4)$ . After drawing a graph and several trial and errors, the students changed the slope and intercept of  $f(x)$  and  $g(x)$ , until they arrived at the solutions of  $f(x)=x$  and  $g(x)=-x+1$ . Although the activity lasted for approximately 30 minutes might seem non-systematic, the act of controlling parameters provided a significant clue for the activities that followed.

So-jung: (After setting the intercept of  $f(x)$  to 0, randomly changing the remaining parameters and observing the shape of the three graphs) Ah, this is so vague.

Soo-yeon: Let's try changing  $f(x)$  to a simpler one.

So-jung: (Inputs  $f(x)=x$ ,  $g(x)=-1/3x+1$ , and  $h(x)=x(-1/3x+1)$ ) Should we increase the slope, instead of  $-1/3$ ?  $-3/4$ ?

So-jung, Soo-yeon: (Inputs  $f(x)=x$ ,  $g(x)=-3/4$ ,  $h(x)=x(-3/4x+1)$ ) Oh.....it's similar.

Soo-yeon: Shall we try increasing the slope of this ( $g(x)$ )?

So-jung:  $5/6$ ? (Inputs  $f(x)=x$ ,  $g(x)=-5/6x+1$ ,  $h(x)=x(-5/6x+1)$ ) It decreased.

Soo-yeon:  $8/9$ ? (Inputs  $f(x)=x$ ,  $g(x)=-8/9x+1$ ,  $h(x)=x(-8/9x+1)$ ) It's decreased even more.

So-jung: (After inputting  $f(x)=x$ ,  $g(x)=-x+1$ ,  $h(x)=x(-x+1)$ ) We got it.

### Empirical Justification in the Process of Establishing and Examining Hypotheses

The students thought that the two linear functions  $f(x)$  and  $g(x)$  should form a right angle in order to satisfy the problem based on what they had learned in the previous session; the slope of  $g(x)$  is  $-1$  and the slope of  $f(x)$  is  $1$  in  $f(x)=x$ ,  $g(x)=-x+1$ . In order to examine the hypothesis, the students thought that for the two functions to form a right angle the common ratio of the slopes of the two functions should be  $-1$ . Based on such an assumption, the students tried inputting  $f(x)=2x$ ,  $g(x)=-1/2x$ , and  $f(x)=3x+1$ ,  $g(x)=-1/3x$ , which are combination of functions that form right angles. They discovered that this did not coincide with the conditions required in the next problem and thus came to the conclusion that a right angle would not be formed. This was the first instance of the use of empirical justification - confirming examples. While the results were mathematically correct, the students did not consider the possibility that there might be a difference once the intercept is changed. As a result,



they concluded that a solution was impossible with the two functions set perpendicularly unless  $f(x)=x$ ,  $g(x)=-x+1$  after examining a few examples. Note worthy is the fact that the students did not attempt to mathematically prove such facts.

After rejecting the first hypothesis, the students believed the slope and the absolute value of  $f(x)$  and  $g(x)$  might be the same while their symbols were opposite. The students then started to examine the hypothesis. Similar to the previous example, after several trial and errors, they reached to the second solution of  $f(x)=2x$ ,  $g(x)=-2x+1$ , which satisfied the conditions given in the problem. Although they began with the slope of  $f(x)$  and  $g(x)$  being 2 as they had previously done, this time the students only changed the intercept.

Soo-yeon: OK..Let's try it. Let's try changing it to 2. (Inputs  $f(x)=2x$ ,  $g(x)=-2x+1/2$ .)  
Hmm... It's roughly similar. Then should we try gradually increasing the y intercept? It kind of hovers.

So-jung: Let's try 1. Oh, come to think of it we already tried 1.

Soo-yeon: Then 3/4? (Inputs  $f(x)=2x$ ,  $g(x)=-2x+3/4$ ,  $h(x)=2x(-2x+3/4)$ .)

So-jung: Since we can't use 1, let's try using a value that's bigger than 1.

Soo-yeon: Bigger than 1? 3/2? (Inputs  $f(x)=2x$ ,  $g(x)=-2x+3/2$ ,  $h(x)=2x(-2x+3/2)$ ) It's not working...

Soo-yeon: It has to be smaller than 1.

So-jung: Smaller than 1? But we already tried doing that and it didn't work. Then try 1.

Soo-yeon: 1? (Inputs  $f(x)=2x$ ,  $g(x)=-2x+1$ .) That's it.

After several attempts, the students found that the two solutions differed in slope while the y intercepts were set at both 0 and 1. In order to meet the requirements of the problem they ascertained that the absolute value of the slopes of the two linear functions  $f(x)$  and  $g(x)$  are the same while the symbols are opposite. They also concluded that only the y intercept, to satisfy the problem, should be 0 and 1. This is a clear example of empirical justification. The researcher, who served as the teacher, could have raised a counter example but did not suggest alternative activities under the judgment that more independent thinking needed to be encouraged.

### **Deductive Justification**

At the beginning of the third session, the teacher tried to remind the students of the results in the second session by suggesting a few examples and counter examples. Through this process, the students discover that the intersection points of  $f(x)$ ,  $g(x)$  and  $h(x)$  always appear on the x axis even when they do not intersect.

When the teacher encouraged the students to ponder why the intersection point is always set on the x axis, at first the students were unable to think of a reason. After a while, the students understood that because  $h(x)=f(x)g(x)$ ,  $h(x)=0$  when  $f(x)=0$ ,  $g(x)=0$ , therefore the intersection point appears on the x axis. The students were also able to conclude that for  $f(x)$ ,  $g(x)$  and  $h(x)$  to meet at the x axis,  $f(x)$  and  $g(x)$  should be symmetrically positioned around the vertex of  $h(x)$  because the teacher

encouraged the students to think of both the point of contact and the intersection point. The students were able to go ahead and deductively justify that, based on such certainty, the slopes of  $f(x)$  and  $g(x)$  should be  $a$  and  $-a$  for the conditions of the problem to be satisfied.

Soo-yeon: But... the intersection point always appears on the  $x$  axis... Why is that?

So-jung: Oh you're right...

Teacher: Let's try thinking of the reason why the intersection point always appears on the  $x$  axis. How is  $h(x)$  made? Isn't it the multiplied value of  $f(x)$  and  $g(x)$ ? Then what do we get when we factorize  $h(x)$ ?

Soo-yeon, So-jung:  $f(x)$  and  $g(x)$ ...

Teacher: Then how do we get the root in a quadratic equation?

(Approximately 10 minutes passes.)

Soo-yeon: Well... since they always meet at the  $x$  axis...hmm.....Ok, I get it... When we factorize  $h(x)$  we get  $f(x)$  and  $g(x)$  so ...  $h(x)=0$  when we use an  $x$  that makes  $f(x)=0$ , and  $g(x)=0$  ...That's quite evident....

Teacher: Think about the intersection point and point of contact.

So-jung: Since it is certain that they meet at the  $x$  axis..... Even if there are two intersection points if we eventually increase it then they meet at the  $x$  axis...Now I see...they meet at the  $x$  axis...so they should be positioned symmetrically...

Soo-yeon: Oh... ok....I see...If  $f(x)$ ,  $h(x)$ , and  $g(x)$  should meet then  $f(x)$  and  $g(x)$  should be symmetrical... and so the slope in the graph .....

So-jung: Oh....from the  $x$  axis.....Then the slope of this ( $f(x)$ ) is  $\tan\theta$ , and this ( $g(x)$ ) is  $\tan(\pi-\theta)$ . Hmm... So if  $f(x)$  is  $a$  then  $g(x)$  is  $-a$ ...I get it..

Soo-yeon and So-jung deductively justified that the symbols of the slopes are opposite. They empirically justified that the intercepts are 0 and 1, respectively, in the second session and connect these two findings. They started proving that  $f(x)=ax$  and  $g(x)=-ax+1$  intersect with  $h(x)=ax(-ax+1)$ .

Soo-yeon: Is this right? (asking the teacher) Since this is how they should meet....We used the discriminant and we got...0.

Teacher: That's right... What does this mean? That the discriminant is 0?...

Soo-yeon, So-jung: They meet.

$$\begin{array}{l}
 y = -ax + 1 \\
 y = ax(-ax + 1) \\
 ax(-ax + 1) = ax \\
 -a^2x^2 + ax = ax \\
 -a^2x^2 = 0 \\
 D = 0
 \end{array}
 \qquad
 \begin{array}{l}
 ax(-ax + 1) = -ax + 1 \\
 -a^2x^2 + ax = -ax + 1 \\
 -a^2x^2 + 2ax - 1 = 0 \\
 D = a^2 - a^2 = 0
 \end{array}$$

Figure 2. Soo-yeon's deductive justification:  $y=ax$ ,  $y=-ax+1$ .

Teacher: As we have seen so far they will meet as long as the symbols of the slopes are opposite and the y intercepts are 0 and 1... But it seems to me that while we've identified that the slopes are numbers of which symbols are opposite, we haven't been able to prove anything about the intercept yet. What kind of formula should we use if we would like to make a proof about the intercepts of  $f(x)$  and  $g(x)$ ?

(After some discussion, the two students put the intercept of  $f(x)$  as  $a$  and the intercept of  $g(x)$  as  $b$  and then use the discriminant to examine the relationship between  $a$  and  $b$ .)

$y = x + a$   
 $y = -x + b$

$y = (x+a)(-x+b)$

$x+a = -x^2 - ax + bx + ab$   
 $x^2 + (a-b+1)x + a-ab = 0$   
 $D = (a-b+1)^2 - 4(a-ab) = 0$

$a^2 + b^2 + 1 - 2ab + 2a - 2b - 2a + 4ab = 0$   
 $a^2 + b^2 + 1 + 2ab - 2b - 2a = 0$   
 $(a+b-1)^2 = 0$

Figure 3. Soo-yeon's deductive justification:  $y=x+a$ ,  $y=-x+b$ .

Consequently, the students deductively identified that since  $a+b-1=0$ , the intercepts of the two functions are not just respectively 0 and 1, but that their added value is 1. The students also tried confirming this by inputting  $f(x)=4/5$ ,  $g(x)=-x+1/5$  and  $f(x)=x+1/2$ ,  $g(x)=-x+1/2$ . When the graph was found to satisfy the given conditions, the students arrived at the final conclusion that the conditions would be satisfied when the slopes of the two functions  $f(x)$  and  $g(x)$  have different symbols with the same absolute value and that the intercepts are added to be 1.

## DISCUSSION

The results of the present research show that two types of justification, namely empirical and deductive justification are displayed in the process of solving algebraic problems using graphing technology. These two types of justification were both stimulated by virtue of graphing technology. In exploring graphs, the students employed mathematical experiments by controlling variables, setting a hypothesis and corroborating the hypothesis. As such the students were able to empirically confirm the hypothesis and move on to deductive justification using the visual clues represented by the graphs. Exploratory activities using technology make accessible aspects that are not possible in a pencil and paper environment. In this respect, such activities open up opportunities for students to advance to broader reasoning.

The empirical justification identified in the present research is slightly similar to the second level found in Simon & Blume (1996), but the deductive justification in this research differs from the third and fourth level in the same study. In view of the fact that the third level exhibited deductive justification through 'particular examples' or

‘comprehensive examples’, it differs from the deductive justification found in this research because it went beyond simply examining specific examples. The deductive justification found in this research is also different with the fourth level in that it did not reach a fully deductive level. Such results have significant implications for mathematics instruction. First, the results show a process of transfer from empirical justification to deductive justification. Such a transfer can be attributed to the visual clues provided by the technology, but it is also important to point out that the suggestions given by the teacher also played an imperative role. The students were certain that their arguments were true by giving a few specific examples that supported their hypothesis, but did not go on to ponder why they came to such a judgment. Therefore the present research sheds light on the need for the teacher’s instructional judgment in deductive justification. This candidly shows the significance of the teacher’s role in the transfer to deductive justification.

Second, the research emphasizes the role of the teacher in the justification process. The role of the teacher as a collaborator helps students draw a line between the ideas formed with the help of graphing technology and the students’ previous mathematical knowledge. Moreover, the role of the teacher as a thought-provoker in mathematical justification was identified. Although the teacher’s role as a collaborator or thought-provoker was not found in the empirical justification process, but it was found in the process of transfer from empirical to deductive justification. There are limitations to solely relying on the use of graphic technology to reach deductive justification. The teacher needs to carefully observe and sensitively respond to the students’ activities and continuously encourage the students to mathematically explain and justify what they have empirically justified. Such results have strong implications for the role teachers should play in order to provide a meaningful learning experience for students in teaching justification in a classroom environment.

## References

- Australian Education Council (1994). *Mathematics: A Curriculum Profile for Australian Schools*. Carlton, VIC: Curriculum Corporation.
- Battista, M. T. & Clements, D. H. (1996). Students' understanding of three-dimensional rectangular arrays of cubes. *Journal for Research in Mathematics Education*, 27, 258-292
- Department of Education (1995). *Mathematics in the National Curriculum*. Kondon, UK: HMSO.
- Harel, G. & Sowder, L. (1998). Students’ proof schemes: Results from exploratory studies. In A.H. Schoenfeld, J. Kaput, & E. Dubinsky (Eds.), *Research in College Mathematics Education III*(pp.234-283). Providence, RI: American Mathematical Society.
- Healy, L. & Hoyles, C. (2000). A study of proof concepts in algebra. *Journal for Research in Mathematics Education*, 31(4), 396-428.
- Hoyles, C. (1997). The curricular shaping of students’ approach to proof. *For the Learning of Mathematics*, 17(1), 7-16.

- Knuth, E. & Elliott, R. (1998). Characterizing the nature of students' understandings of mathematical proof. *Mathematics Teacher*, 91(8), 714-717.
- Lannin, J. K. (2005). Generalization and justification: The challenge of introducing algebraic reasoning through patterning activities. *Mathematical Thinking and Learning*, 7(3), 231-258.
- Ministry of Education (1999). *Senior High School Curriculum (in Japanese)*. Tokyo, Japan: MOE
- Ministry of Education and Human Resources Development(2007). *Mathematics Curriculum (in Korean)*. Seoul, Korea: MOEandHRD.
- National Council of Teachers of Mathematics (2000). *Principles and Standards for School Mathematics*. Reston, VA: NCTM.
- National Council of Teachers of Mathematics (1991). *Professional Standards for Teaching Mathematics*. Reston, VA: NCTM.
- Simon, M. A. & Blume, G. W. (1996). Justifications in the mathematics classroom: A study of prospective elementary teachers. *Journal of Mathematics Behavior*, 15(1), 3-31.

# TEACHING ASSISTANTS' USES OF WRITTEN CURRICULUM IN ENACTING MATHEMATICS LESSONS FOR PROSPECTIVE ELEMENTARY TEACHERS

Jane-Jane Lo

Western Michigan University

Rae-Young Kim and Raven McCrory

Michigan State University

*In research universities, teaching assistants often act as instructors in lower division mathematics courses. Typically, they are provided with a written curriculum (e.g. textbooks and/or lesson plans) for their courses. In this study, we explore how these resources are utilized or adapted. Two teaching assistants were observed while they taught three fraction lessons in a mathematics course for future elementary teachers. Interviews were conducted before and after the lessons to gather further information on their views of the course and the written curriculum. Results showed that the instructors enacted only a little over 50% of the textbook content. We discuss several factors that influenced how they adapted the written curriculum.*

## **OBJECTIVES**

Teaching assistants (TAs) play a vital role in undergraduate mathematics instruction. Acting as sole instructors, recitation instructors, tutors, or homework graders, they are in frequent contact with undergraduate students in the lower division mathematics courses such as college algebra, pre-calculus, and mathematics courses for prospective K-8 teachers (Speer, Gutmann and Murphy, 2005). Typically, new and less experienced TAs are given specific syllabi, curriculum materials, timelines, and lesson plans to follow when preparing their lessons. Often, they also receive some support from a course coordinator and more experienced teaching assistants. However, very little is known about how TAs utilize various types of resources in planning and teaching their courses. Such information is needed for designing effective professional development opportunities for TAs. In this paper, we report results from a study with two teaching assistants conducted during a fraction unit for prospective elementary teachers. Specifically, we seek to identify 1) the roles the written curriculum played in the planning and enactment of these fraction lessons, 2) the adaptations TAs made to the written curriculum when enacting the lessons, and 3) the factors that influenced the TAs' decision-making.

## **THEORETICAL FRAMEWORK AND PRIOR STUDIES**

Our study focuses on two components of Stein, Remillard, & Smith's (2007) temporal phases of curriculum use: written curriculum and enacted curriculum. Stein et al (2007) describe the written curriculum as the printed materials available to the teachers such as teacher editions and implementation guides. The enacted curriculum consists of the interactions between the teacher and students as the lessons unfold within the classroom (Remillard, 2005). Teachers implement curricula in many different ways. A large survey on the extent of textbook use by 39 middle school

mathematics teachers found that many teachers supplemented their regular curricula routinely with practice worksheets regardless of whether it was an NSF-funded or a commercially published curriculum (Tarr, Reys, Barker, & Billstein, 2006).

Stein et al. (2007) identified three types of teacher factors that have been used to examine the adjustments teachers made between the written and the enacted curriculum: beliefs and knowledge, orientation toward the curriculum, and professional identity. Remillard & Bryan (2004) found that it was teachers' orientations toward the curriculum (e.g. adherent and trusting, quietly resistant, skeptical, etc.) rather than their views of mathematics or teaching that had a significant impact on their enacted curricula. Teacher's professional identity, defined as "individual's way of understanding and being" in the profession (p. 208) by Spillane (2000), has also been identified as a factor influencing curriculum use and the construction of the teacher's role in the class (Spillane, 2000). He found that a fifth grade teacher formed different identities as a teacher and learner toward language art and mathematics instructions, and these differences led to different enactment of reform curricula. In this study, we use the concept of teacher's identity in a limited way: focusing on how TAs view their roles as instructors of a mathematics class for elementary teachers and how they conceive the goals of the course.

While there is research in K-12 settings about the relationship between the written and enacted curricula, no study exists examining this relationship in college mathematics classes with a specific focus on graduate teaching assistants. The results of this study will help fill that gap.

## **METHODS**

The study was conducted during the fall semester 2007 in a course *Mathematics for Elementary Teachers* at a large research university in the Midwest. The course is one of two mathematics courses required for elementary certification. During the semester of the study, there were eight sections taught by five different TAs. One full professor acted as supervisor of the course who provided instructional and curricular support through weekly meetings. This course focuses on numbers and operations, and uses *Elementary Mathematics for Teachers* (Parker and Baldrige, 2003) as the primary textbook. This textbook is unique in that it is designed to be used in conjunction with the *Primary Mathematics* textbook series (Singapore Ministry of Education, 2003).

### **Participants**

Two TAs, Jamie and Sam (pseudonyms) who were instructors of *Mathematics for Elementary Teachers*, participated in this study. Both are working toward PhD's in mathematics education. Jamie has a master's degree in mathematics education from Korea and a master's degree in mathematics from the institution at which this research was conducted. She taught high school mathematics in Korea before she came to the United States. This is her third time teaching this course using the same curriculum materials. Sam has bachelors and master's degrees in mathematics from an institution in the United States. Although she taught Chinese in elementary and

middle schools in the United States, she had never taught mathematics until she taught this course. She was a research assistant for two years before applying for this TA position in the mathematics department.

### **Data Sources and Analyses**

Several types of data were collected for this study. The written curriculum includes: units 6.1, 6.2, and 6.3 in *Elementary Mathematics for Teachers* (Parker and Baldrige, 2003), detailed lesson plans written by one of the authors, and handouts TAs received from the course coordinator. The topics of these lessons are fraction definitions, models, ordering, addition, subtraction and multiplication. The data on the enacted curriculum includes video tapes and field notes taken during the teaching of those three units. These TAs' enacted curricula were analysed for adaptations by comparing them to the written curriculum. In addition, the two TAs were interviewed about curriculum use, additional resources, their interpretation of the goals and their roles in this course, and their ideas about teaching fractions.

To understand the nature of the adaptations made by the instructors, we first analysed the textbook, identifying main ideas, examples and exercises in those three sections. We then went through the corresponding video tapes and coded each element from the textbook analysis as being discussed or skipped. For each discussed idea, example or exercise, we coded them further as faithful (i.e., identical to the textbook description), or modified. We also identified any new idea, example, or exercise that was added by the instructors.

We identified emerging themes within each subgroup of adaptations: discussed faithfully, discussed with modification, skipped, and added. Once these themes were identified, hypotheses were formed about the factors that might have influenced their decisions. Similar analysis of the interview notes were used to help with triangulation to form and verify hypotheses generated for the three research questions.

## **RESULTS**

### **The roles of the written curriculum**

Both instructors had similar orientations toward the use of written curriculum. They used the textbook not only as the main resource for planning and conducting their classes but also as a tool for classroom management and communication between the instructor and students. Since neither instructor had experience teaching elementary school mathematics before they taught this course, the textbook and the accompanying books from the *Primary Mathematics* were important resources for their own learning. Also, the textbook provided them with information on the topics and sequence of this course as well as how the main concepts could be explained. They expected their students to read the textbook before coming to the class and they assigned homework problems from the textbook.

Even though both instructors used the textbook as a guide for their planning and instruction, they both regularly chose not to use the activities and examples directly



from the textbook. Jamie said that if she followed the textbook exactly, some of her students might think that she did not prepare for class. She worried that students might decide not to engage if class work duplicated the textbook, thinking that they could just catch up on their own by studying the textbook themselves.

Sam believed that introducing new activities or problems could serve as a motivator. She felt that when she brought in non-textbook activities, her students were more engaged, which entailed more interaction with her students and helped build more trust between her and her students. These comments pointed to some factors that influence TAs uses of the textbook. In the next two sections, we will first characterize the types of adaptations these TAs made when enacting three fraction lessons and then explore possible factors that influence their decisions both from their actions and from additional comments that they made during the interviews.

### **Adaptations made by the two TAs**

The textbook authors recommended three 50 min. lessons for these three units for a total of 150 minutes. While Jamie spent about 178 min. and taught 58% of the ideas, examples and exercises in the textbook, Sam spent about 196 min. and taught 55% of the content of the textbook. The amounts of time noted above were instructional time on those three units not including time spent on administrative tasks or quizzes.

Both TAs made modifications to a significant portion of the ideas, examples and exercises that were in the written curriculum when enacting them in the classroom: only 42% of Jamie's instruction and 30% of Sam's instruction were faithful, that is, identical to the textbook description. And these are mainly rules, models, exercises and examples discussed in the book.

*Modifications:* Our analysis indicated that the majority of the modifications made by Jamie and Sam were either changing the numbers or the contexts of the given examples or exercises. However, these modifications occurred quite differently in these two TAs' lessons. Sam frequently asked students to give examples to the ideas being discussed. For example, when discussing the meaning of mixed numbers and improper fractions, Sam asked students to give definitions and examples for both. Students came up with  $1\frac{1}{8}$  and  $\frac{5}{2}$  while the textbook gave three examples,  $2\frac{1}{8}$  for the mixed numbers,  $\frac{8}{5}$  and  $\frac{7}{7}$  for the improper fractions to highlight both the ">" and "=" in the definition of " $a/b, a \geq b$ ". In Jamie's lesson, she chose three examples herself:  $2\frac{1}{3}$ ,  $\frac{7}{2}$  and  $\frac{5}{5}$ . While Jamie's adaptation did not change the intent of the textbook, Sam's failed to address one important feature of the definition for improper fractions: a fraction  $a/b$  is considered improper if  $a=b$ .

In addition, both Jamie and Sam often encouraged their students to utilize fraction models (e.g. set, area/region, and linear measurement) that were different from those specified in the textbook. This type of modification tended to arise naturally in Sam's

class as she encouraged her students with questions such as, “how can you explain this problem to the second graders?”, and “If your student makes an error like this, how could you help him or her?” Furthermore, she encouraged her students to consider the strength and weakness of each model for solving a problem. Jamie initiated various fraction models as part of her planned lessons for additional practice. The focus of the discussion was explaining the solution of a given problem with different ways of using model.

*Skipped Content:* Further analysis of the skipped ideas and exercises indicated that they fell into three main categories. The first category is connections with whole numbers or algebra. In the textbook, these are discussions that extend rules, models and properties for whole numbers to fractions. The second category is ideas and examples related to teaching elementary students. For example, both Jamie and Sam skipped the discussion that once elementary students learned the rule for fraction-division equivalence ( $a \div b = a/b$ ), they would be able to understand that the question “what is 17 divided by 4?” has four answers (4R1,  $\frac{17}{4}$ ,  $4\frac{1}{4}$ , 4.25) depending on the context of the question. The third category includes specific examples and exercises for illustrating or practicing certain mathematical ideas, such as comparing two fractions by comparing them both to an intermediate fraction. While both Jamie and Sam skipped about the same number of textbook ideas, examples, and exercises - 28 and 29 respectively- they distributed differently among the three categories.

Primary foci	Mathematical Connection	Teaching Connection	Mathematics Examples/Exercises
Jamie (n=29)	11 (39%)	15 (54%)	2 (9%)
Sam (n=28)	8 (21%)	14 (48%)	7 (24%)

Table 1. Distribution of skipped textbook content

*Added Content:* Even though neither TA taught all the main ideas and examples in the textbook, they each added examples during the classes. In total, Jamie added 7 examples, and Sam added 9. All Jamie’s added examples had more mathematical complexity than the cases given in the textbook. For example, the textbook used only examples involving proper fractions when looking at cases of whole numbers times fractions and fractions times whole numbers, while Jamie’s examples involved improper fractions. She also added a multi-step fraction word problem that required explicit attention to shifting quantities used to represent the wholes.

Sam added nine examples throughout the three units. In contrast to Jamie’s added examples that all appeared to push students by using more complex fraction quantities or situations, Sam’s examples were intended to provide additional opportunities for students to think through exercises they might have difficulty with, to compare/contrast with what they had done earlier, or to motivate her students with

activities that were taken from the elementary mathematics curriculum. For example, Sam started the fractions unit with an activity “Fractions of a Square” where students were asked to decide what fraction each of the nine pieces (of various shapes) is in relation to the whole square. Toward the end of section 6.3 Sam added two additional exercises, solving  $\frac{1}{2} + \frac{1}{3}$  and  $\frac{1}{2} \times \frac{1}{3}$  and to make clear the difference between the fraction addition and multiplication.

## **FACTORS THAT INFLUENCE THE ENACTED CURRICULUM**

Our analysis of the interview data and the nature of adaptations made by these two TAs suggest that the instructors’ role and the goals that they set up for their classes shaped their decisions about how to use the curriculum. Jamie viewed herself as a *mathematics instructor* and wanted her students to learn more rigorous and profound mathematical knowledge from this class. She commented during the interview that even though her students would be teachers in elementary schools, they should know more than elementary school mathematics. She thus saw herself as a mediator who provided a bridge between the mathematics that mathematicians do and the mathematics her students were learning. She attempted to provide her students with more complicated mathematical problems that required complex reasoning.

Sam, on the other hand, saw herself as a *mathematics teacher educator* and wanted to help her students understand elementary mathematics as it applied to their future teaching. She pointed out that even though this course was a mathematics course, it was important to consider that her students would be teachers in elementary schools. She wanted to encourage her students to think about how to teach and what made mathematics difficult for elementary students. She thought she could be a facilitator and role model to develop their knowledge for teaching. She aimed to offer her students more opportunity to think about various ways of teaching a mathematical concept. The TAs’ different conceptions of goals and their roles as instructors led to different curriculum transformations.

Another factor we found was contextual restraints such as time, content coverage, and administrative pressures. Since this course was taught by different instructors, the TAs felt the pressure of maintaining certain level of consistency in terms of content coverage and pacing. Both TAs thought that they were behind other instructors. They both commented that even though they wanted to use more elementary students’ activities with their students, they were not able to do so because of the lack of time.

Finally, we found that students’ engagement and responses were one of the factors that influence the use of the written curriculum. Both instructors felt that it was hard to motivate their students to engage in the class. Thus, it became more important to invent other ways to encourage their students such as providing new problems and activities that the textbook did not cover. Jamie, who taught two sections of the class, adjusted her instruction according to students’ engagement and readiness. She said that since her students in the class that we observed were

less active and usually less prepared for the class than the other section that she taught, she said that she eventually supplemented with fewer problems and activities in the class than the other section and stayed with lecture and less discussion in the class we observed.

## DISCUSSION

Our data suggest that even though the instructors' orientation toward the written curriculum were similar and they taught the same course with the same written curriculum, a variety of factors influenced the TAs' use of the written curriculum. These include their interpretation of the goals of the course, their perception of their roles as instructors, contextual constraints and support, and students' engagement and readiness. Since this course is designed for prospective elementary teachers, it makes sense that TAs could be more mathematics-oriented or more pedagogy-oriented in their interpretation of the goals of the course and their self-determined roles in this course. The results from a recent survey with 63 college instructors of courses for prospective elementary teachers also showed variety in their goals for such courses (McCrory et al, 2008). Such variety may produce different ways of using the written curriculum and different learning opportunities for prospective teachers.

Both TAs spent more time than the textbook authors had suggested (178 and 196 minutes compared to 150 minutes suggested) but they were able to address only a little over 50% of the textbook content. Interestingly, the majority of the materials they skipped were connective pieces in both mathematical and pedagogical senses: they skipped ideas connecting fractions to the whole number system or the algebraic properties, and issues connecting to the elementary curriculum or K-8 students' reasoning. Why did they both give lesser attention to the mathematical and pedagogical connections? How might such adaptation influence prospective elementary teachers' mathematical learning in this course as well as their opportunities to make connections to their future studies? These are questions need further study.

A related issue that we have not addressed in this study is the level of the alignment between the adaptations these TAs made and the written curriculum. Seago (2007) introduced three categories of adaptation: fatal, no impact, and productive. "Fatal" adaptations run counter to the essential characteristics of the materials. "No impact" adaptations do not contradict the important design principles of the curriculum nor are they aligned with these principles. "Productive" adaptations are aligned with the essential characteristics of the curriculum. Currently, we continue to analyse the adaptations made by these two TAs to determine if they were productive in promoting the deep understanding of mathematics as called for by *The Mathematics Education of Teachers* (Conference Board of the Mathematical Sciences (CBMS), 2001).

## Endnote

This research is funded by the National Science Foundation (Grant No. 0447611). The authors wish to thank the two instructors who generously participated in this project and the other team members - Zhang Hui Chang, Andrea Francis, Helen

Siedel, and Sarah Young - who collected data and participated in discussions that made our analysis possible.

## References

- Conference Board of the Mathematical Sciences (2001). *The Mathematical Education of Teachers* (Vol. 11). Providence, RI: American Mathematical Society American Mathematical Society and Mathematical Association of America.
- McCrory, R. S., Francis, A. P., & Young, S. H. (2008). Resource Use by Instructors of Mathematics Classes for Future Elementary Teachers: Results of a Survey. *ICMI 11*, Topic Study Group 27, Deborah Ball & Jill Adler, Chairs.
- Parker, T. H. & Scott J. B. (2003). *Elementary Mathematics for Teachers*, Okemos, MI: Sefton-Ash Publishing.
- Remillard, J. T. (2005). Examining key concepts in research on teachers' use of mathematics curricula. *Review of Educational Research*, 75, 211-246.
- Remillard, J. T. & Bryans, M. (2004). Teacher's orientations toward mathematics curriculum materials: Implications for teacher learning. *Journal for Research in Mathematics Education*, 35, 352-388.
- Seago, N. (2007). Fidelity and adaptation of professional development materials: Can they co-exist? *NCSM Journal*, 9(2), 16-25.
- Singapore Ministry of Education (2003). *Primary Mathematics*. Oregon City, OR: Singapore: Times Media Private Ltd.
- Speer, N., Gutmann T., & Murphy, T. J. (2005). Mathematics teaching assistant preparation and development. *College Teaching*, 53, 75-80
- Spillane, J. P. (2000). A fifth-grade teacher's reconstruction of mathematics and literacy teaching: Exploring interactions among identity, learning, and subject matter. *Elementary School Journal*, 100(4), 307-330.
- Stein, M. K., Remillard, J., & Smith, M. S. (2007). How curriculum influences student learning. In F. K. Lester (Ed.), *Second Handbook of Research on Mathematics Teaching and Learning* (pp. 319-369).
- Tarr, J. E., Reys, B. J., Barker, D. D., & Billstein, R. (2006). Selecting high quality mathematics textbooks. *Mathematics Teaching in the Middle School*, 12(1), 50-54.

# CHARACTERISING ALGEBRAIC LEARNING THROUGH ENACTIVISM

Maria-Dolores Lozano

Cinvestav - ILCE

*I report on a characterisation of algebraic learning which was guided by an enactivist theoretical framework. Ideas emerged within a longitudinal study investigating the learning of algebra in two schools through the observation of effective behaviours in different classrooms. Six themes, which supported ways of acting algebraically in different ways, were identified in the patterns of students' behaviours. Through the enactivist analysis of these themes, algebraic learning was found to be promoted in classrooms where the embodied, rational, emotional and social aspects of learning were taken into account. In these environments, where students found a need for the use of algebra, and where acting algebraically became part of their behaviour, procedures were substantiated with explanations and justifications and were carried out within the exploration of mathematical structure.*

## INTRODUCTION

In the learning of mathematics, one of the most important areas is algebra. The fact that algebra is somehow a link between arithmetic and higher mathematics makes it not only significant but fundamental for many students. In mathematics education, a large amount of papers have been written on what algebra means, on how people learn it and on different teaching approaches and experiments. Current research shows, however, that the learning of algebra is a complex process which occurs differently in different contexts and it seems desirable to explore what happens in classrooms in depth. In this paper I describe how enactivism, a theory of knowing about learning which stems from the work of Maturana & Varela (1992), allowed me to characterise the learning of algebra in a complex way, accounting for different aspects that influence the learning processes. This work is part of my doctoral project, which consisted of a two-case longitudinal study that had as its purpose to investigate, in a detailed manner, the learning of algebra in different contexts.

## SOME IDEAS ABOUT THE LEARNING OF ALGEBRA

What do we mean by 'learning algebra'? In enactivism, learning is the ongoing structural change that occurs in individuals (or groups) as a result of continuous interactions with an ever changing environment (Maturana and Varela, 1992). From this perspective, learning is always considered in a relational context (*ibid*, p. 174). Since cognition is about action and actions occur in particular locations then learning has to be evaluated in relation to the situation in which it occurs. Knowledge, in a particular setting, is associated with adequate conduct or effective behaviour. Individuals organise their structures as they interact with the world, determined by their history. If the organisation leads to 'adequate functioning' (Davis, 1996, p. 200)

then we can consider that learning has taken place. Effective behaviour, or adequate functioning means to ‘operate effectively in the domain of existence’ (Maturana & Varela, 1992, p. 29); that is, to act in ways that allow the learner to continue existing in an environment, to perform actions that are acceptable. Different criteria of acceptability will be specified in different contexts. Behaviour that is not effective will lead to the interruption of interactions and eventually will prevent the individual from continuing to participate in the particular context in which the actions are not acceptable.

In enactivism learning algebra occurs when individuals interact with each other, acting effectively and changing their behaviour in a similar way. In a particular context or location, the participants create together the conditions that will allow actions to be adequate. In a mathematics lesson, teacher and students create a culture in which certain activities are considered to be effective algebraically. For example, solving equations in a precise manner can be effective in one algebra classroom, while in another effectiveness can be considered in terms of posing equations during problem solving.

As individuals act together in a certain context, they will construct a history of interactions; future interactions will then be influenced by past history. Algebraic learning occurs as a result of histories, both at individual and collective levels. The purpose of my doctoral study was to approach algebraic learning through the exploration of effective behaviours in different contexts, looking at how histories were built through recurrent interactions.

### **Algebraic activity**

In every classroom, there will be particular behaviours which might be considered algebraic, but in order to explore algebraic learning I needed a definition which I could use in order to distinguish algebraic activity from other kinds of behaviour. For this purpose, I used Kieran’s (1996) categories of algebraic activity:

- *Generational activities* - These involve the generating of expressions and equations that are the objects of algebra. [...]
- *Transformational activities* - Rule-based activities of algebra, for example, collecting like terms, factoring, expanding, substituting, solving equations, simplifying expressions and so on. [...]
- *Global, meta-level, mathematical activities* - Problem solving, modelling, finding structure, justifying, proving and predicting. [...] (Kieran, 1996, online; italics in the original)

The enactivist perspective and Kieran’s categories allowed me to expand my original research question ‘How does algebraic learning occur in different classrooms contexts throughout time?’ into a number of sub-related questions: What does effective behaviour mean in different mathematics classroom contexts? How does effective behaviour change in different classroom contexts throughout time? What can I say about effective behaviour in terms of algebraic activity, according to

Kieran's (1996) definition? In the next section I briefly discuss some methodological issues related to the way in which I addressed these questions throughout my project.

## METHODOLOGY AND METHODS

The choice of methods used in my investigation of algebraic learning was also inspired by the enactivist approach. 'Enactivism, as a methodology [is] a theory for learning about learning' (Reid, 1996, p. 205). Research is considered to be a way of learning, and therefore researchers are seen as individuals developing their learning in a particular context. The interdependence of context and researchers makes the research process a flexible and dynamic one.

### Investigating the effective behaviour

In order to research the learning of algebra, I contacted two schools in the city of Puebla, Mexico. The schools, which I called School 1 and School 2, were located around the same area of the city and both admitted students from middle-class communities. I selected these particular schools because they had different styles of teaching, School 1 being more traditional and School 2 having a more progressive approach. I wanted to explore effective behaviour in contexts which were quite different in order to enrich my perspectives on algebraic learning.

In Mexico, algebra is 'formally' introduced during the first years of secondary school (years 7 and 8), so I decided to select groups of students in Year 6 and then follow them for three years. I started with 2 groups in School 1 and 1 group in School 2 (Groups A, B and D). In the last year, the two groups in School 2 became 3 groups, because the school decided to select certain students for a special group. Since I was tracking individual students as well as following the groups, I did observations for 4 groups in my last year (Groups A, B, C and D) (See Lozano, 2004 for a detailed description of the schools and of each of the classrooms I observed).

	SCHOOL 1			SCHOOL 2
GROUPS/YR6	A	B		D
GROUPS/YR7	A	B		D
GROUPS/YR8	A	B	C	D

Table 1. Longitudinal Design of the Study

I accessed students' effective behaviour through lesson observations, interviews and a mathematics test. Throughout my research project I observed approximately 100 hour-lessons. I was in the schools for one month each year for the duration of the study. The first three weeks were devoted to classroom observations, and during the last week I conducted individual interviews in order to investigate more deeply students' algebraic learning (30 interviews each year). At the end of the study I gave all the students in the groups I observed sections of a test designed by the Mexican



Ministry of Education. The questions I focused on were the ones related to algebraic activity. The test is fairly traditional, including equations to solve and problems to symbolize in algebraic expressions and equations. For my data analysis and reflections on algebraic learning, I used Kieran's categories of algebraic activity in order to classify behaviours as algebraic or non-algebraic.

## **EFFECTIVE BEHAVIOURS IN THE CLASSROOM**

As I analysed effective behaviours that I identified through lesson observations, interviews and the test, six categories emerged: active / passive; attentive / inattentive; working with others / working individually; freedom / constraint; explaining / having correct answers; understanding, thinking, reasoning / remembering.

The patterns that I found during the observations and in the students' responses to the interviews revolved around these themes. Many more categories can be added to this list, these are not the only aspects that can be considered when thinking of a learning environment. It is impossible, however, to describe an environment in its entirety. These themes reflect some of the principal differences between the different learning environments, both from my perspective and that of the students. They do not represent dichotomies; there were elements of all the different aspects in each classroom. For example, students in a given environment were free to do certain activities and constrained in other ways.

Throughout my longitudinal study, I looked for effective behaviours which I could characterise as algebraic according to Kieran's categories. I cannot describe here, in detail, the actions I observed at each stage of my research for each of the classrooms I investigated (see Lozano 2004 for a detailed description of algebraic activities). My intention in this paper is to describe how each of the general aspects of behaviour mentioned above supported algebraic learning in different ways and how they allowed me to characterise algebraic learning. Kieran's categories of algebraic activity are involved in this characterisation of algebraic learning. I start by reflecting on each of the themes that emerged in my analysis and I later describe my characterisation of algebraic learning.

### **Aspects of Effective Behaviour**

#### **Active / Passive**

Students' behaviour in the different classrooms included being physically active in a variety of ways. The activities I observed included giving opinions, solving problems, explaining ideas from the front, measuring shapes, calculating, and many more. In some classrooms, students were less active; they were quiet most of the time, and their work mainly consisted in solving exercises on their workbooks.

Enactivism tells us that our actions shape our structures and hence our learning. The kinds of activities students did in the classroom were therefore an important component of their effective behaviour and hence of their algebraic learning. Students who were participants in classroom cultures where they could engage in a wide variety of activities

had greater opportunities for developing cognitive structures such as mathematical concepts. In the end, students in those groups (A, B and C in my study) were able to act algebraically in a more flexible way, showing that some algebraic notions and ideas had become part of their behaviour. In those classrooms, the development of students' algebraic learning explicitly involved both their mind and their body.

#### Attentive / Inattentive

Being attentive was another characteristic of students' behaviour in the different groups. Cognition, from an enactivist perspective, is shaped by our particular structures at any given moment (Maturana and Varela, 1992, p.242). Individuals select, from the environment, the features that will trigger changes in them. We only notice certain things that happen around us and what we notice will influence our future actions.

In some lessons students appeared to be very attentive, listening to their teacher and their peers. In others, students seemed distracted and directed their attention to activities that were not related to the lesson or to mathematics. During the last year, for example, students in groups 8B and 8C were especially attentive, noticing features like generality and mathematical structure. They found their tasks during that year interesting and I believe this was the result of not only carefully designed activities, but also of students having built histories of interactions which allowed them to engage naturally in algebraic activity. In previous years, students had appeared to be motivated, their opinions had been addressed and their preferences had been taken into account. Ways of acting are always related to emotional tones. In some of the classrooms I observed, where engaging in mathematical activity was part of the students' behaviour, children said they enjoyed their lessons, while in other groups, they found them boring, and even stressful (groups 8A and D):

ML: Can you tell me about the maths lessons you've enjoyed the most?

Leo 2: Algebra. [...] I like it, it is fun. (Leo/7B)

Marta 3: None, he he [...] Because, it is ... it is like ... more boring, because, because we changed teachers, hum, don't know this teacher instead of doing more exercises he talks more. (Marta/8A)

In a classroom culture where students' preferences were accounted for, stronger links were built between positive emotional undertones and algebraic activity. Algebraic learning cannot be separated from emotions, because they are part of our individual structure, which in turn selects features from the environment that trigger changes in us. Directing the attention towards something, which will influence algebraic learning, is a result of a complex interplay between action, reason and emotion.

#### Working individually / Working with others

Another important aspect of students' behaviour involved their degree of interaction with others. In some classrooms, students worked together most of the time, forming small groups and discussing their ideas within them. During other lessons, students worked on their own. According to enactivism, the types of interaction we have with

our environment will shape our learning, as interactions trigger changes in our structures. Moreover, interactions shape all the participants' structures. Working with others is different from interacting only with the teacher and the textbooks. There is a higher chance of going through structural change if an individual is in contact with different ideas which can trigger those changes. In addition, building histories of interactions with other people is crucial in allowing individuals to develop common ways of acting. Algebraic learning is likely to occur when people develop particular ways of looking at phenomena. These particular ways emerged, in my study, as people worked together, sharing ideas and developing a common ground for action.

#### Freedom / Constraint

Students' actions were shaped by restrictions imposed by the teacher in each classroom. This also seemed to differentiate the groups I studied to a great extent. In some groups students were free to explore the problems and situations they faced while in others they tightly followed very precise directions. In addition, there was one particular classroom in which students were almost completely free and could decide whether they worked on mathematics problems or not.

Having opportunities for exploration is important from an enactivist perspective because, as we said before, individual structures allow students to select certain features from the environment and at the same time the actions they perform will modify these structures. Being offered opportunities to interact with problems in different ways might allow more students to notice and to find ways of engaging with the activities, hence modifying their structures. In environments where students were too constrained, the individual nature of learning was not taken into account. Conversely, when students were left entirely to their own devices, the collective nature of learning was dismissed. Algebraic learning has more possibilities for developing when both the individual and the collective aspects are supported.

#### Explaining / Having correct answers

Amongst the actions I observed in the classrooms, the ones that led students to present an acceptable solution for a problem or question seemed to be both interesting and important when differentiating the groups. Explaining and justifying occurred frequently and seemed a necessary condition for the acceptance of a solution in some environments (class 6A, group B and group C). In others, giving a correct answer to a problem was enough (8A and group D). Furthermore, in this case the correctness of the answer was mostly determined by the teacher, while in the classrooms where students developed justifications, the criteria that determined whether an answer was correct or not was open to negotiation given that students discussed the justifications that substantiated the answer. One of the implications of these differences is that in some environments students were participants in the creation of particular ways of acting that constituted the subject matter, in this case algebra. Because the groups as a whole, including teachers and students, participated in determining whether an answer with an explanation was

acceptable or not, algebra was part of the students' behaviour, and not a set of rules that was imposed from the outside.

### Understanding / Remembering

Finally, when I observed the classrooms and interviewed the students, I found a strong difference in what the participants perceived as being important for the learning of mathematics. While in some groups students and teachers talked about 'understanding, thinking and reasoning', in others they mentioned 'remembering'. These activities are not directly observable and their meaning is also deeply ambiguous. Further exploration, however, revealed that in most cases understanding was taken as 'knowing how' and/or 'know why'. Remembering, in contrast, was related to studying and memorising.

'Knowing how' and 'knowing why' can be interpreted as ways of acting in a particular moment. Students in groups A, B and C were used to giving explanations, which included both how and why something worked. Being able to explain is something that belongs to the realm of action, therefore inevitably related to the body. Memorising, studying and remembering are also actions; however, they remind us more of intangible mental activity, rather than concrete embodied behaviour. When memorising is seen as the main activity involved in the learning of mathematics, mathematical activity is seen as abstract and intellectual rather than embodied and concrete. 'Knowing how' and 'knowing why' also encompass a notion that involves other people, and reflects a flexible process of explanation that can never be fully completed. Remembering, in contrast, relates more to facts that individuals possess. Facts are static and, once they are internalised, do not need further revisiting.

Algebraic learning, from an enactivist perspective, encompasses embodied actions, mental dynamics and interactions with other people. It cannot be considered as possessing internal representations of external facts or concepts. Ideas are 'understood' only when there is a history of interactions that allows individuals to behave coherently in a given context. 'Knowing why' and 'knowing how' are ways of acting that can allow individuals to behave in a coherent manner in their mathematics lessons. In environments where these actions were effective, students developed a more flexible kind of algebraic learning (especially groups B and C).

## **CHARACTERISING ALGEBRAIC LEARNING**

The enactivist framework and the data I collected through my three-year longitudinal study led me to characterise algebraic learning as the structural change that occurred in individuals or groups as they acted effectively in a context in which algebraic activity was *needed*. This took place when a history of interactions, in which algebraic activity became part of the students' behaviour, was created. Algebraic learning emerged through the acknowledgement of the rational, emotional, embodied and social character of algebraic learning. It was promoted in classroom contexts where individuals were offered opportunities in which they could engage, in the company of others, in ways of working algebraically. In these contexts, students were

encouraged to explain and justify their ideas, because it was through the process of explanation that algebraic meanings were produced, shared and modified.

In these environments, the different kinds of algebraic activities occurred in the process of collective exploration of mathematical problems which address the students' preferences and already existing ideas. *Transformational and generational* activities did not occur in isolation, but always in the process of exploration of structure. Therefore, they occurred through *global, meta-level activities*. In the contexts where algebraic learning was fostered, the exploration of mathematical structure was also linked to generalisation, which could occur without the use of algebraic symbols. Generational and transformational activities were still important, however, because algebraic symbolism was taken as a powerful tool for expressing and exploring mathematical structure. Algebraic learning was supported by classroom cultures where students were encouraged to use algebra to explain and justify mathematical situations. Stress was put on global, meta-level activities without abandoning the more mechanical aspects.

A culture in which algebra is used in the process of exploration of structure together with the elaboration of explanations and justifications automatically creates a need for the use of algebraic symbols and procedures, therefore promoting algebraic learning. The algebraic meanings that were developed in this kind of culture allowed the students in my study to act in more flexible ways because in these environments algebraic activity became part of the students' behaviour. When students naturally engaged in algebraic activity, as a result of their previous history of interactions, they were able to shape their already existing meanings and to integrate different concepts and procedures into their behaviour, that is, they are involved in algebraic learning.<sup>1</sup>

## References

- Davis, B. (1996) *Teaching Mathematics: Toward a Sound Alternative*, New York, Garland Publishing.
- Kieran, C. (1996) 'The Changing Face of School Algebra' in Selected Lectures from the 7th International Congress on Mathematical Education, Sevilla [online] available from <[http://www.math.uqam.ca/\\_Kieran/art/algebra.html](http://www.math.uqam.ca/_Kieran/art/algebra.html)> [accessed 14-11-00]
- Lozano, M. D. (2004). *Characterising Algebraic Learning: An Enactivist Longitudinal Study*. Unpublished doctoral dissertation, University of Bristol.
- Maturana, H. & Varela, F. (1992). *The Tree of Knowledge: The Biological Roots of Human Understanding*. Revised Edition, Boston, Shambala.
- Reid, D. (1996). Enactivism as a Methodology. In L. Puig and A. Gutierrez (Eds.), *Proceedings 20<sup>th</sup> Conference of the International Group for the Psychology of Mathematics Education* (Vol. 4, pp. 203-209). Valencia, Spain: PME.
- Varela, F. (1999). *Ethical Know-How: Action, Wisdom and Cognition*. Stanford, Stanford University Press.

---

<sup>1</sup> Adapted from Hughes-Hallet, et. al. (1994) *Calculus*. New York, NY: John Wiley and Sons, Inc.

# TAIWANESE AND U.S. PROSPECTIVE ELEMENTARY TEACHERS' FUNDAMENTAL KNOWLEDGE OF FRACTIONS

Fenqjen Luo

University of West Georgia

Jane-Jane Lo

Western Michigan University

Yuh-Chyn Leu

National Taipei University of Education

*One hundred and seventy-four prospective elementary teachers, eighty-five from Taiwan and eighty-nine from the U.S., took a 15- item test that covered a wide range of fundamental knowledge of fractions. Preliminary results showed that prospective elementary teachers from Taiwan outperformed their U.S. counterparts on twelve of the fifteen items. Further performance analysis identified several areas of strength for both educational systems.*

## **OBJECTIVES**

One of the main goals of educational research is to improve the quality of education for all students. International comparative studies provide unique opportunities to study issues in teaching and learning from a broader perspective. Such understanding can help identify potential factors that contribute to the differences in outcomes, and provide insights into ways to improve education through changes in policy and practices (Cai, 2004). For example, the results of the Trends in International Mathematics and Science Study (TIMSS) Video Studies of Teaching have contributed to the increasing interests in using Japanese Lesson Study as the basis of many professional development programs in the U.S (Lewis, Perry, Hurd, & O'Connell, 2006). While there is a long history of international comparative studies that have focused on the teaching and learning of k-12 students, teacher education has only recently become an area of interest among policy makers in many countries. This is due to the growing body of research that support the critical role teacher knowledge plays in providing quality instruction (Tatto et. al., 2007). In this study, we investigate the similarities and differences in Taiwanese and U.S. prospective elementary teachers' fundamental knowledge of fractions. By focusing on one critical component of elementary mathematics, fractions, this study seeks to identify and explain the outcome differences and make specific suggestions for improving mathematics programs for the prospective teachers.

## **THEORETICAL FRAMEWORK AND PRIOR STUDIES**

Shulman (1986) proposed three categories of content knowledge for teachers, a) subject matter content knowledge, b) pedagogical content knowledge, c) and curricular knowledge. For Shulman, subject matter content knowledge includes knowing a variety of ways in which “the basic concepts and principles of the discipline are organized to incorporate its facts” and “truth or falsehood, validity or

invalidity, are established” (p. 9). Kahan, Cooper & Bethea (2003) found that prospective teachers’ mathematics content knowledge influences their lesson planning and teaching. It follows that a better understanding of mathematics teacher education programs around the world and the mathematics content knowledge gained by their students would have great significance because of the important role they play in shaping the prospective teachers’ subject content knowledge.

In this study, we investigate the subject matter content knowledge possessed by Taiwanese and U.S. prospective elementary teachers needed to introduce fraction concepts and operations. We chose fractions as the topic of study because it is an important and challenging topic in elementary mathematics for both teachers and students. Research studies on U.S. prospective teachers’ mathematics knowledge have shown that many possess limited knowledge of mathematics in the area of whole number and rational number operations (Ball, 1990; Graeber, Tirosh & Glover, 1989; Simon, 1993). However, more studies are still needed in other topic areas in order to provide insight into ways of developing the kind of deep understanding of mathematics called for by Ma (1999) and the Conference Board of the Mathematical Sciences (CBMS, 2001). As pointed by the authors of *The Mathematical Education of Teachers* (CBMS, 2001),

the key to turning even poorly prepared prospective elementary teachers into mathematical thinkers is to work from what they *do* know- the mathematical ideas they hood, the skills they posses, and the contexts in which these are understood- so they can move from where they are to where they need to go (p. 17).

Thus, this study fills the need for specific information about the mathematics knowledge for teaching related to fractions.

When comparing Chinese and U.S. students’ solution strategies and use of representations in patterning and ratio/proportion types of problems, Cai and his colleagues found that both U.S. teachers and students preferred to use pictorial solution strategies and while their Chinese counterparts preferred to use symbolic strategies (Cai, 2004; Cai & Wang, 2006). How deeply rooted is this difference? Can this difference be traced back to the fraction concepts that are typically taught before ratio/proportion topics? This study is the first step of identifying curricular factors that might account for the difference in performance.

## **METHODOLOGY**

Based on the theoretical framework and prior research studies outlined above, the current study sought to answer the following research question: “What is the level of fraction knowledge possessed by prospective elementary teachers in Taiwan and the U.S., and how is the nature of this knowledge similar or different?” To illustrate this nature with two examples from our own hypotheses, we asked whether both prospective elementary teachers from Taiwan and the U.S. found it harder to conceptualize fractions with set models than with area/region models, and whether they had similar error patterns when choosing the correct story problems for

representing fraction operations. Furthermore, we were interested in knowing whether the U.S. teachers, like their student counterparts, would exhibit preference for pictorial strategies when reasoning with fraction concepts.

One hundred and seventy-four prospective elementary teachers participated in this study: eighty-five from a university in northern Taiwan and eighty-nine from two universities in the states of Georgia and New Jersey in the U.S. The test consists of 15 items in seven sub-categories. Table 1 provides a summary of these categories.

Sub categories	Item Numbers
Fraction as Part-Whole (Set model)	#2 #6
Fraction as Part-Whole (Area/Region model)	#4, #7
Fraction as Part-Whole (Linear Measure/Number Line model)	#8, #9
Fraction as Quotient	#3, #5
Fraction Comparison	#1, #10, #11
Fraction Representation	#13, #14, #15
Multi-Step Word Problem	#12

Table 1. Subcategories of the 15-item test

To test the influence of pictorial representation, #2, #4, #7, #8, #11 have a pictorial model embedded. In addition, we set up the following pairs of comparison: #2 and #6 have the same mathematical structure, but only #2 has a pictorial model as part of the problem statement. #3 and #5 have the same mathematical structure but different contexts that tend to lead to different representations. With the exception of one item (#12) that requires multiple computation steps, all other items require minimal computation that can be done by applying fundamental fraction concepts. The resulting Cronbach's Alpha for the total scale is 0.736.

## RESULTS

### Comparing the two performances

The mean score for prospective teachers in Taiwan was 12.64 (84.3%) with a standard deviation of 1.792. The mean score for the U.S. counterparts is 8.84 (58.9%) with a standard deviation of 2.449. The percentages of correct responses by prospective teachers on each item are listed in Table 2.

#1	#2	#3	#4	#5	#6	#7	#8	#9	#10	#11	#12	#13	#14	#15
95.3	91.8	83.5	95.3	90.6	83.5	87.1	85.9	98.8	94.1	85.9	74.1	95.3	23.5	78.8
83.1	62.9	36.0	75.3	76.4	53.9	76.4	33.7	64.0	61.8	84.3	40.4	83.1	19.1	33.7

Table 2. Percentage of correct answer of each item



Prospective elementary teachers in Taiwan outperformed their U.S. counterparts on all fifteen items. The difference is statistically significant ( $\alpha = 0.05$ ) on twelve of fifteen items using t-test without assuming the same variability within each subgroup. Two of the items that show no significant difference in performance are included below in Table 3. One common characteristic of the first two items is the area/region model presentation. A third such item, #14, was also the hardest item for both groups. We will discuss this item in detail in the next section.

<p>7. Using the picture on the right, divide the shaded portion into six equal parts. Highlight <math>\frac{1}{6}</math> of the shaded part. What portion of the circle was highlighted?</p> <p>(a) <math>\frac{1}{6}</math> (b) <math>\frac{1}{7}</math> (c) <math>\frac{1}{8}</math> (d) <math>\frac{3}{4}</math> (e) None of the above.</p>	
<p>11. In the two identical rectangles, which one has more shaded area?</p>	
<p>(A) </p>	<p>(B) </p>
<p>(a) (A) has more. Because it looks bigger.          (b) (A) has more. Because <math>3/10 &gt; 3/9</math>          (c) The same because they both have 3 pieces.          (d) (B) has more. Because <math>3/10 &lt; 3/9</math> (e) None of the above.</p>	

Table 3. Two items that show no significant difference

The item that had the highest percentage of correct responses by prospective elementary teachers from Taiwan is the following story problem: “Jim jogged  $1 \frac{1}{2}$  miles yesterday. This is  $\frac{3}{8}$  of his weekly goal. How many miles does he plan to run each week?” This item could favour a symbolic strategy and it was likely that prospective elementary teachers in Taiwan solved this problem by setting up a simple linear equation  $\frac{3}{8} \times \text{whole trip} = 1 \frac{1}{2}$  which led to a fraction division  $1 \frac{1}{2} \div \frac{3}{8}$ . This result is consistent with those found in Cai and Wang (2006).

We also noted that three (#4, #7 and #11) of the top six items have pictorial models accompanying the problem statements, while two others were embedded in familiar every day contexts such as sharing/dividing cakes (#1 and #5).

### Challenging items

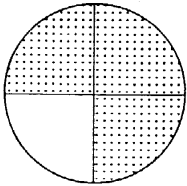
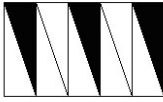
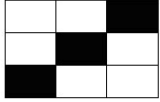
To further understand the nature of the fundamental knowledge of fractions possessed by prospective elementary teachers in Taiwan and the U.S., we arranged all the items from the highest to the lowest percentage of correct answers (See Table 4).

	High														Low
Taiwan	#9	#1	#4	#13	#10	#2	#5	#7	#8	#11	#3	#6	#15	#12	#14
U.S.	#11	#13	#1	#5	#7	#4	#9	#2	#10	#6	#12	#3	#8	#15	#14

Table 4. The sorted lists based on the percentage of correct responses

Four out of the five hardest items are the common to both groups. These items feature quotient division in linear measurement context (#3), multi-step word problems (#12), representing fraction multiplication and division either with story problem or pictorial models (#14 and #15).

Despite finding the same items challenging, there are differences in their solution patterns. Item #3 asked prospective teachers to fold a 2-meter strip of paper into three equal pieces and identify the length of each piece. While some answered correctly that each piece would be  $\frac{2}{3}$  meter long, teachers from both groups submitted incorrect responses of  $\frac{1}{3}$  meter and 0.66 meter.

Among those incorrect answers, 25.8% prospective teachers from U.S. chose  $\frac{1}{3}$  meter and 14.6% chose 0.66 meter, while only 2.4% of the prospective teachers from Taiwan chose  $\frac{1}{3}$  meter, and the most common error was the 8.2% chose 0.66 meter. The differences in the incorrect response patterns reflect different types of conceptual difficulty. An answer of  $\frac{1}{3}$  meter would indicate that the teacher focused only on the “one” piece of strip divided into “three” equal pieces, and failed to notice that the “quantity” for each piece needed to be measured with the standard unit, “meter.” This is different from those answering 0.66, who had an oversight or error in precision.

As mentioned above, #14 was the most challenging task for Taiwanese and U.S. prospective elementary teachers. Only 19.1% of the U.S. and 23.5% of the prospective teachers in Taiwan answered this problem correctly. The statement of the problem is included below.

14. Which of the following pictures **cannot** be used to model  $\frac{3}{4} \times \frac{4}{5}$  or  $\frac{4}{5} \times \frac{3}{4}$ ?

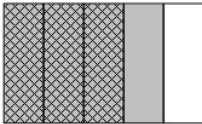

(a)

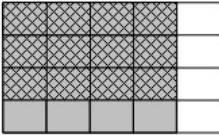

(b)

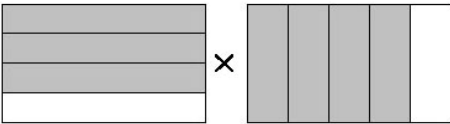

(c)

(d) All of the above.      (e) None of the above.

The negative nature of the item, choosing the model that would work instead of the model that will work, might have misled some prospective elementary teachers.

This conjecture was supported by the fact that both groups of prospective elementary teachers performed quite well on another item of fraction representation (#13) when the problem asked to identify the correct story problem that matched the given fraction subtraction. However, a follow-up discussion of this item revealed gaps in prospective elementary teachers’ understanding of fraction operations. Many prospective elementary teachers in Taiwan and the U.S. chose a) as the answer because they saw that the whole for  $\frac{4}{5}$  was a rectangle containing 5 parts, while the whole for  $\frac{3}{4}$  was a smaller rectangle containing 4 parts. They believed the whole for  $\frac{4}{5}$  and  $\frac{3}{4}$  should be drawn to the same size as in (c). These prospective elementary teachers focused on just representing the “fractions” in the number sentence but ignored the embedded “operation.” For them, the pictorial model for  $\frac{3}{4} + \frac{4}{5}$  would look exactly the same as  $\frac{3}{4} \times \frac{4}{5}$ , except having a different operation sign in the middle. This type of modelling does not contribute to the conceptualization of possible solution strategies. This may be an area that needs additional attention from both countries.

**Influence of the pictorial models**

Recall that out of all fifteen items, only five items had pictorial models embedded in the story and two of those, #7 and #11 discussed earlier, were among the only three items that had no significant difference in performance between Taiwan and the U.S. To exam the influence of the pictorial models further, we compared prospective elementary teachers’ performance on the following pair of items.

Taiwan	U.S.	Problem Statements
91.8%	62.9%	<p>2. A basket contained 8 red apples, 2 bananas and 4 green apples. What fraction of the apples is green?</p> <p>(a) <math>\frac{4}{14}</math> (b) <math>\frac{4}{12}</math> (c) <math>\frac{8}{12}</math> (d) <math>\frac{4}{8}</math></p>  <p>(e) None of the above.</p>
83.5%	53.9%	<p>6. Brandon has a box which contains 7 red marbles, 3 purple buttons, and 5 green marbles. What fraction of the marbles is green?</p> <p>(a) <math>\frac{5}{15}</math> (b) <math>\frac{5}{12}</math> (c) <math>\frac{7}{12}</math> (d) <math>\frac{5}{7}</math> (e) None of the above.</p>

Notice that both items have the same mathematical structure and both Taiwanese and U.S. prospective elementary teachers performed better when the pictorial representation was present. However, did all types of pictorial representation help? To answer this question, we exam the performance of the only remaining item that had a pictorial representation embedded in the problem, #8. The problem statement and the percentage of correct answers from both Taiwan and the U.S. are listed.

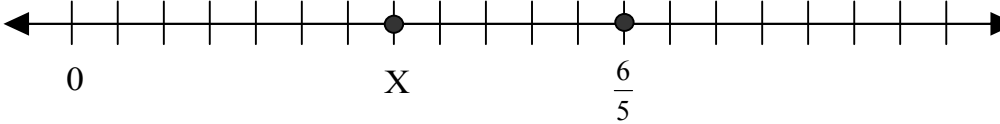
Taiwan	U.S.	Problem Statements
85.9%	33.7%	<p>8.</p>  <p>What is the value of x?</p> <p>(a) <math>7/12</math>      (b) <math>3/5</math>    (c) <math>7/10</math>    (d) <math>7/15</math></p> <p>(e) None of the above</p>

Notice that while the percentage of correct responses by prospective elementary teachers from Taiwan maintained at relative high level despite of the relatively more complex nature of this problem, the percentage of correct responses by prospective elementary teachers from the U.S. was less than satisfactory. It appeared that the number line was not as well understood as the other two common pictorial representations for fractions for prospective elementary teachers in the U.S.

We found further evidence of this last point when comparing U.S. prospective elementary teachers' performance on another paired item, #3 (dividing a 2-meter paper strip into three equal pieces) and #5 (below).

- #5. Aunt Rachel had 2 cupcakes for the kids to share equally. There were three kids. How much did each kid get?
- (a) 2 cupcakes    (b)  $3/2$  cupcakes    (c)  $2/3$  cupcake    (d)  $1/3$  cupcake
- (e) None of the above.

The percentage of correct responses dropped from 76.4% for #5 to 36.0% for #3. In the former, only 12.4% chose  $1/3$  cake vs. 25.8% choose  $1/3$  meter for #3. So U.S. prospective elementary teachers did seem to have a better grasp of the mathematical idea when the context supports region/area than linear measure/number line model.

**Implications and Future directions**

Fundamental knowledge of fractions is a building block for many upper elementary/middle school mathematical topics. The findings of this study suggest that the performance difference between Taiwanese and U.S. students may be rooted at the basic mathematics level and persistent throughout the entire educational system. Time and attention need to be invested to address at the fundamental levels.

The findings of the study also point out that the U.S. prospective elementary teachers in this study do perform at the same level as the prospective elementary teachers in Taiwan when a pictorial area/region model is present or suggested by the context, yet, there is no support for similar advantages with other fraction models such as set or linear measure. Further studies are needed to explore ways to support prospective elementary teachers in the U.S. to strengthen their fundamental knowledge of fractions so that they will be more equipped to help their elementary students develop such knowledge.

## References

- Ball, D. L. (1990). The mathematical understandings that prospective teachers bring to teacher education. *The Elementary School Journal*, 90, 449-466.
- Cai, J. (2004). Why do U.S. and Chinese students think differently in mathematical problem solving? Impact of early algebra learning and teachers' beliefs. *Journal of Mathematical Behavior*, 23, 135-167.
- Cai, J. & Wang (2006). U.S. and Chinese teachers' conceptions and constructions of representations: A case of teaching ratio concept. *International Journal of Science and Mathematics Education*, 4, 145-146.
- Conference Board of the Mathematical Sciences (2001). *The Mathematical Education of Teachers* (Vol. 11). Providence, RI: American Mathematical Society American Mathematical Society and Mathematical Association of America.
- Graeber, A., Tirosh, D., & Glover, R. (1989). Preservice teachers' misconceptions in solving verbal problems in multiplication and division. *Journal for Research in Mathematics Education*, 20, 95-102.
- Kahan, J. A., Cooper, D. A., & Bethea, K. A. (2003). The role of mathematics teachers' content knowledge in their teaching: A framework for research applied to a study of student teachers. *Journal of Mathematics Teacher Education*, 6, 223-252.
- Lewis, C., Perry, R., Hurd, J., & O'Connell, P. (2006). Lesson study comes of age in North America. *Phi Delta Kappan*, 88, 273-281.
- Ma, L. (1999). *Knowing and Teaching Elementary Mathematics: Teachers' Understanding of Fundamental Mathematics in China and the United States*. Hillsdale, NJ: Erlbaum.
- Shulman, L. S. (1986). Those who understand: knowledge growth in teaching. *Educational Researcher*, 15(2), 4-14.
- Simon, M. A. (1993). Prospective elementary teachers' knowledge of division. *Journal for Research in Mathematics Education*, 24, 233-254.
- Tatto, M. T., et al. (2007). Teacher Education and Development Study in Mathematics (TEDS-M 2008). *Conceptual Framework. Field Trial*. Teacher Education and Development International Study Center, East Lansing, MI: College of Education, Michigan State University.

# BUILDING ON CHILDREN'S INFORMAL KNOWLEDGE IN THE TEACHING OF FRACTIONS

Emma Mamede

University of Minho

Terezinha Nunes

University of Oxford

*This paper describes a teaching experiment in which children were introduced to fractions using quotient, part-whole or operator situations. Differences between situations are analysed by comparing what children learn about quantities that are represented by fractions in each of these situations, and whether they transfer this learning across situations. The study involved first-graders, aged 6 to 7 years, from Portugal who had not been taught about fractions before. Quantitative analyses showed that children developed a better understanding of equivalence and order of fractional quantities in quotient situations, but there was no transfer of learning to the other two situations. In part-whole and operator situations they only learned how to label fractions and were able to transfer this learning across these two situations.*

## FRAMEWORK

According to Vergnaud's (1997) theory, to study and understand how mathematical concepts develop in children's minds through their experience in and out of school, one must consider a concept as depending on three sets: a set of situations that make the concept useful and meaningful; a set of operational invariants used to deal with these situations; and a set of representations (symbolic, linguistic, graphical etc.) used to represent invariants, situations and procedures. This paper analyses the effect of situations on children's learning about invariants related to quantities that are represented by fractions and learning how to label these quantities using fractions.

Different classifications of situations where the concept of fractions is used are presented in the literature. Kieren (1993) distinguished four situations: measure (which includes part-whole), quotient, ratio and operator. He terms these 'subconstructs' of rational number, involving various elements of knowing. Behr, Lesh, Post, & Silver (1983) distinguished part-whole, decimal, ratio, quotient, operator, and measure as subconstructs of rational number concept. More recently, Nunes, Bryant, Pretzlik, Evans, Wade, & Bell (2004), based on the meaning of numbers in each situation, distinguished four situations: part-whole, quotient, operator and intensive quantities. In all these different classifications, part-whole, quotient and operator situations are considered. These were the three situations selected to be included in the study reported here.

In part-whole situations, the denominator designates the number of parts into which a whole was cut and the numerator designates the number of parts taken. So,  $\frac{2}{4}$  in a part-whole situation means that a whole (for example, a chocolate) was divided into four equal parts, and two were taken. In quotient situations, the denominator designates

the number of recipients and the numerator designates the number of items being shared. In a quotient situation,  $2/4$  means that 2 items (for example, two chocolates) were shared among four people. Furthermore, it should be noted that in quotient situations a fraction can have two meanings: it represents the division and also the amount that each recipient receives, regardless of how the chocolates were cut. For example, the fraction  $2/4$  can represent two chocolates shared among four children and also can represent the part that each child receives, even if each of the chocolates was only cut in half (Mack, 2001; Nunes, Bryant, Pretzlik, Evans, Wade, & Bell, 2004). In operator situations, the denominator indicates the number of equal groups into which a set was divided and the numerator is the number of groups taken (Nunes et al., 2004). For example, if a boy is given  $2/4$  of 12 marbles, this indicates that the 12 marbles were organized into 4 groups (of 3 marbles each) and the boy received 2 of the 4 (i.e. 6 marbles). Do these differences affect children's understanding of fractions when teaching is designed to build on their informal knowledge?

Applying Vergnaud's (1997) theory to the understanding of fractions, one also needs to consider a set of operational invariants that can be used in these situations. Thus one has to ask how children come to understand that there are classes of equivalent fractions ( $1/3$ ,  $2/6$ ,  $3/9$ , etc) and that these classes can be ordered ( $1/3 > 1/4 > 1/5$ ; Nunes et al., 2004). In which situations do children understand best the relations between the numerator, the denominator and the quantity represented? The invariants analysed in this paper are equivalence and ordering of the magnitude of quantities that should be represented by fractions (more specifically, the inverse relation between the divisor and the magnitude).

Children's informal knowledge of quantities that are labelled by fractions has not been systematically analysed across situations but it is possible to look across studies to attempt to develop a hypothesis about whether children have informal knowledge of fractional quantities in these different situations. Empson (1999) found some evidence that 6- and 7-year-olds can use of ratios with concrete materials to solve equivalence problems. In part-whole situations, Piaget, Inhelder and Szeminska (1960) found that older children, 6- and 7-year-olds could understand the equivalence between parts, but only if these parts came from sequential subdivisions (e.g.  $2/4$  obtained by dividing  $1/2$  in two parts). Concerning operator situations, (Empson, 1999) showed that children aged 6 to 7 years found the operator concept very difficult.

Children's understanding of the inverse relation between the divisor and the quantity represented by a fraction was analysed by Kornilaki & Nunes (2005) in quotient situations, where the children were asked to order the quantities that would result from divisions. Fractional representations were not used but the dividend was smaller than the divisor (e.g. 1 fishcake shared by 3 cats was compared to 1 fishcake shared by 5 cats). More than half of the 6-year-olds and all 7-year-olds tested succeeded in this comparison. The equivalent insight using part-whole situations would be that the larger the number of parts into which a whole was cut, the smaller the size of the parts (Behr, Wachsmuth, Post, & Lesh, 1984), but this insight has not been

documented in children of these age levels. Similarly, there is no evidence to show that children understand that the larger the number of groups formed by a division in operator situations, the smaller the number of items in each of the groups.

This study analysed children's knowledge of fractions after a brief teaching experiment, where the children were randomly assigned to learn about fractions by solving problems either in quotient, or part-whole or operator situations. For simplicity, tasks involving the equivalence and ordering of quantities represented by fractions are referred to here as "logical tasks"; problems where the children are asked to provide a symbolic representation are referred to as "labelling tasks". We investigated whether the situation in which the concept of fractions was presented to the children influenced their learning of logical and labelling aspects of fractions. First, the differences in children's learning across the situations were analysed by comparing their performance in a pre- and a post-test test. Second, it was analysed whether the children transferred what they had learned in one situation to the other two. It was predicted that, if situations really make a difference to the children's understanding, there should be little transfer across situations after a short-term teaching experiment.

## **METHODS**

### **Participants**

First-grade Portuguese children (N=37), aged 6 to 7 years, from two primary schools from the city of Braga, in Portugal, were assigned to work in groups. These children had not been taught about fractions in school, although the words 'metade' (half) and 'um-quarto' (a quarter) may have been familiar in other social settings. The children in were seen by an experimenter, a native Portuguese speaker, in small groups for the teaching sessions and individually for the pre- and post-tests.

### **Design**

In each school, four groups of about five children were assigned to be introduced to fractions using only one type of situation. This produced one Quotient Intervention Group, one Part-whole Intervention Group, one Operator Intervention Group and one Control Group. The Control Group solved problems involving multiplicative structures and did not work with quantities represented by fractions.

The children first answered a pre-test, where they were asked to solve problems in all three situations; after the teaching sessions, they answered a post-test, which also contained problems in all three situations.

The pre-test was followed by two teaching sessions lasting approximately 35 minutes and carried out in the small groups. In the first session, the children received instruction on how to label fractions and then were asked to solve two labelling problems and two ordering problems. In the second session, they were asked to solve two problems of equivalence of quantities represented by fractions. After each child had attempted the problem individually, the experimenter asked them to discuss their answer in the small group and provided feedback and explanations.



**The tasks**

An example of each type of task is presented in Table 1, Part A and B. The instructions were presented orally in Portuguese; the children worked on booklets that contained drawings which illustrated the situations described. The problems are presented here in abbreviated format and translated into English.

Problem	Situation	Example
Ordering	Part-whole	Bob and Emma each have a bar of chocolate the same size; Bob breaks his bar into 2 equal parts and eats 1 of them; Emma breaks hers into 3 equal parts and eats 1 of them. Write in the box the fraction that represents the amount of chocolate that Bob eats. Write in the box the fraction that represents the amount of chocolate that Emma eats. Does Bob eat more, less or as much chocolate as Emma? Circle Bob if you think that he eats more; circle Emma if you think that she eats more; circle both if you think that they eat the same amount of chocolate.
	Quotient	Two boys are going to share a chocolate bar fairly; three girls are going to share fairly a chocolate bar of the same size. Write in the box the fraction that represents the amount of chocolate that each boy is going to eat. Write in the box the fraction that represents the amount of chocolate that each girl is going to eat. Does each boy eat more, less or the same amount of chocolate as each girl? Circle the boys if you think that each boy is going to eat more; circle the girls if you think that each girl is going to eat more; circle both if you think that each girl is going to eat as much as each boy.
	Operator	Eve and Ruth each have a box with 6 lollypops. Eve splits the lollypops from her box into 2 equal groups and puts 1 group in her red bag to eat later. Ruth divides the lollypops from her box into 3 equal bags and puts 1 group in her blue bag to eat later. Write the fraction that shows the part of the box of lollypops that Eve put in the red bag. Write the fraction that shows the part of the box of lollypops that Ruth put in the blue bag. Does the red bag have more lollypops than the blue bag? Does the blue bag have more lollypops than the red one, or do they have the same number of lollypops? Circle Eve if you think that she has more in her red bag; circle Ruth if you think that she has more in her blue bag; circle both if you think that they have the same.

Table 1. Types of problem presented to the children in each Intervention Group, Part A

Equivalence	Part-whole	Bill and Ann each have a pizza to eat. Their pizzas are equal. Bill cuts his pizza in 3 equal parts and eats 2 of them; Ann cuts hers into 6 equal parts and eats 4 of them. Write in the box the fraction that represents how much pizza Bill ate. Write in the box the fraction that represents how much pizza Anna ate. Did Bill eat more, the same, or less than Ann? Circle Bill if you think that he ate more; circle Anna if you think that she ate more; circle both if you think that they ate the same.
	Quotient	Three boys are going to share 2 pizzas fairly; six girls are going to share 4 pizzas fairly. The pizzas are equal and there is no pizza left at the end. Write in the box the fraction that represents how much pizza each boy is going to eat. Write in the box the fraction that represents how much pizza each girl is going to eat. Will each boy eat more, less or the same amount of pizza as each girl? Circle the boys if you think that each boy is going to eat more; circle the girls if you think that each girl is going to eat more; circle both if you think that each girl is going to eat as much as each boy.
	Operator	Bill and Anna each have a box with 12 sweets. Bill divides his sweets into 3 equal bags and is going to eat the sweets from 2 bags. Anna divides hers into 6 equal bags and is going to eat the sweets from 4 bags. Write the fraction that represents the part of the box of sweets that Bill is going to eat. Write the fraction that represents the part of box of sweets that Anna is going to eat. Does Bill eat fewer, more or as many sweets as Anna? Circle Bill if you think that he eats more; circle Anna if you think that she eats more; circle both if you think that they eat the same.

Table 1. Types of problem presented to the children in each Intervention Group, Part B

After the children had written their answer to each problem, they discussed these in the small groups. In the ordering problems, the aim of the experimenter was to lead them to think about the fact that the greater the divisor, the smaller the quantity. This took different forms in each situation (e.g. In the quotient situation, the experimenter would ask the children: if there are more children sharing one chocolate, will each one get more, less or the same? In the part-whole situation, the experimenter would ask the children: if you cut the chocolate into more parts, will each part be bigger, smaller or the same size?) In the equivalence problems, the aim of the experimenter was to lead the children to think about the relation between the numerator and the denominator. This took different forms in each situation (e.g. If there are twice as many children and twice as many chocolates, is it possible that they would eat the same amount? If there the boy eats twice as many pieces as the girl, but his pieces are half the size, is it possible that they eat the same amount?)

**RESULTS**

In order to analyse whether the interventions were effective and whether one type of intervention led to greater improvement across the problems than the other, six ANCOVAs were planned. The covariate was Pre-test performance. In three of these, the dependent variable was the children’s post-test performance in the logical problems; each analysis considers post-test performance in one of the problem situations. In the remaining three analyses, the dependent variable was the post-test performance in the labelling problems, and each analysis considers the performance in one situation. The Type of Intervention Session (Quotient, Part-whole, Operator, or Control) was the independent, between-participants factor.

It was predicted that teaching would show specific effects: children would improve significantly in the situation in which they had been taught, but there would be no transfer across situations.

The covariates (pre-test results) predicted significantly the children’s performance at post-test when the measure was the children’s performance in the logical tasks. As there was a floor effect at pre-test in the labelling tasks, the analysis of post-test results was then simply an ANOVA.

Table 2 presents the means of the children in the different types of teaching groups in the post-test performance in each of the three types of situations. For the logical problems, these means are adjusted for pre-test performance.

Type of situation used in the Intervention		Type of situation used in Post-test problems					
		Quotient		Part-whole		Operator	
		Logic	Label	Logic	Label	Logic	Label
Quotient	Mean	8.6	10.8	0	0.9	0	1.9
n=10	(SD)	(3.13)	(1.62)	-	(2.51)	-	(4.18)
Part-whole		3	2.6	0.6	9.7	0	9.4
n=10		(3.71)	(4.14)	(1.9)	(2.78)	-	(4.97)
Operator		3.8 (3.65)	1.2	0	10.3	0	11.6
n=10			(3.8)	-	(1.42)	-	(0.7)
Control		3	0	1.57	0	1.71	0
n=7		(4.51)	-	(4.16)	-	(4.53)	-

Table 2. Means and standard deviations (in brackets) of the children’s scores on problems of logic and labelling of fractions in each situation in the Post-test by Type of Situation used in the Intervention group (Max=12)

The results are quite simple. The children who were taught in the Quotient situations significantly out-performed the other children in logical and labelling tasks in

quotient situations. They had made progress from pre- to post-test in these situations and their improvement was significant. The children who were taught in the Part-whole and the Operator situations made no progress in the logical tasks from pre- to post-test and did not differ from the other groups at post-test in their ability to solve equivalence and ordering problems in the situations in which they had been taught. They did, however, improve in their ability to use fractional representation in the situation in which they were taught and differed significantly both from the Control and the Quotient group in the labelling tasks. Surprisingly, there was transfer in the use of fraction labels by children in the Part-whole and Operator groups: both groups performed significantly better than the Control and the Quotient groups when asked to label fractions in part-whole and operation situations. However, they were at sea when asked to label fractions in Quotient situations.

## **DISCUSSION AND CONCLUSION**

Although this teaching experiment was very brief, it produced clear and important results. The children in the three taught groups received the same amount of instruction and solved problems that were formally equivalent during this instruction. During the teaching sessions, they did consider the arguments presented by the experimenter to promote reflection about the equivalence and ordering of fractions. The children were presented with two problems of each kind, order and equivalence, in the teaching sessions. When the children were discussing the second problem, some were able to use the same arguments that the experimenter had presented to them in connection with the first problem. This was observed even in the Part-whole and Operator groups, where no progress was documented from pre- to post-test. However, it seems that only the children in the Quotient group assimilated these arguments and developed an insight into the logic of fractions during the teaching sessions. Children in the Quotient group also showed no difficulties in learning to use the dividend as the numerator and the divisor as the denominator to represent fractional quantities. As predicted, there was no transfer across situations in such a short-term teaching experiment. When the children were introduced to fractions in Quotient situations, they were quite successful in learning, but there was no sign of transfer to the other situations.

Children's learning in Part-whole and Operator situations was different from learning in Quotient situations. They were quite successful in learning symbolic representations, and transferred this learning between these two situations, but the logic of equivalence and ordering of fractions seemed to elude them.

These findings suggest that Quotient situations can be very helpful for children to establish the connection between their informal ideas about quantities that can be represented by fractions and the formal representation of fractions. Quotient situations seem to be, as suggested by Streefland, the best ones for the introduction of fractions to children. But it is possible that without explicit instruction children's understanding will be restricted to these situations. However, it is not possible to reach this sort of conclusion after such a brief teaching experiment and further research should explore whether a deeper understanding of this situation can lead to

transfer or whether situation effects on the children's performance will remain significant without explicit teaching for transfer.

## References

- Behr, M., Lesh, R. Post, T., & Silver, E. (1983). Rational-Number Concepts. In R. Lesh & M. Landau (Eds.), *Acquisition of Mathematics Concepts and Processes* (pp. 91-126). New York: Academic Press.
- Behr, M., Wachsmuth, I., Post, T., & Lesh, R. (1984). Order and Equivalence of Rational Numbers: A Clinical Experiment. *Journal for Research in Mathematics Education*, 15, 323-341.
- Empson, S. (1999). Equal Sharing and Shared Meaning: The Development of Fraction Concepts in a First-Grade Classroom. *Cognition and Instruction*, 17(3), 283-342.
- Kieren, T. (1993). Rational and Fractional Numbers: From Quotient Fields to Recursive Understanding. In T. Carpenter, E. Fennema, & T. Romberg (Eds.), *Rational Number - An Integration of Research* (pp.49-84). Hillsdale, New Jersey: LEA.
- Kornilaki, E. & Nunes, T. (2005). Generalising principles in spite of procedural differences: Children's understanding of division. *Cognitive Development*, 20, 388-406.
- Mack, N. (2001). Building on informal knowledge through instruction in a complex content domain: Partitioning, units, and understanding multiplication of fractions. *Journal for Research in Mathematics Education*, 32, 267-295.
- Nunes, T., Bryant, P., Pretzlik, U., Evans, D., Wade, J., & Bell, D. (2004). Vergnaud's definition of concepts as a framework for research and teaching. *Annual Meeting for the Association pour la Recherche sur le Développement des Compétences*, Paper presented in Paris: 28-31 January.
- Piaget, J., Inhelder, B., & Szeminska, I. (1960). *The Child Conception of Geometry*. New York: Harper and Row.
- Vergnaud, G. (1997). The nature of mathematical concepts. In T. Nunes and P. Bryant (Eds.), *Learning and Teaching Mathematics - An International Perspective* (pp. 5-28). East Sussex : Psychology Press.

# PARADOX AS A LENS FOR EXPLORING NOTIONS OF INFINITY

Ami Mamolo and Rina Zazkis

Simon Fraser University

*This study examines university students' approaches to infinity, before and after instruction, via their engagement with a well-known paradox: the Ping-Pong Ball Conundrum. Students' work revealed they perceive infinity as an ongoing process, rather than a completed one, and fail to notice conflicting ideas. We describe specific challenging features of this paradox, as well as the persuasive factors in students' reasoning that might influence an understanding of infinity.*

The counterintuitive nature of infinity, as manifested in students' reasoning, has attracted interest of many researchers (e.g. Dreyfus & Tsamir, 2004; Fischbein, 2001; Fischbein, Tirosh, & Hess, 1979). Our study extends this research, using students' struggle to make sense of a well-known paradox, the Ping-Pong Ball Conundrum, as a lens into their understanding of infinity.

The Ping-Pong Ball Conundrum (Burger & Starbird, 2000) is one of many paradoxes that illustrate the complex nature of infinity. From Zeno's paradox to Hilbert's Infinite Hotel, the question of what happens to an infinite iteration once the process is complete has delighted and puzzled mathematicians and philosophers for centuries. Untangling a paradox takes considerable intellectual effort, particularly when dealing with infinity. Paradoxical statements regarding the infinite stem from the seemingly impossible attributes of mathematical infinity, and tend to expose preconceptions that were once believed to be fundamental. Quine (1966) classified such paradoxes as falsidical - ones that "not only [seem] at first absurd but also [are] false, there being a fallacy in the purported [proofs]" (p. 5). These 'fallacies' can arise from erroneously extending familiar properties of finite concepts to the infinite case, or from the belief that infinity is synonymous with eternity.

In an on-going study, we explore university students' responses to a selection of paradoxes regarding infinity. In this paper we examine students' naïve and emerging conceptions of infinity as they confront conceptual challenges arising in their attempts to resolve the Ping-Pong Ball Conundrum.

## **PING-PONG BALL CONUNDRUM**

The paradox can be presented in the following way:

Imagine you have an infinite set of ping-pong balls numbered 1, 2, 3, ..., and a very large barrel; you are about to embark on an experiment. The experiment will last for exactly 1 minute, no more, no less. Your task is to place the first 10 balls into the barrel and then remove number 1 in 30 seconds. In half of the remaining time, you place balls 11 - 20 into the barrel, and remove ball number 2. Next, in half of the remaining time (and working more and more quickly), place balls 21 - 30 into the barrel, and remove ball

number 3. Continue this task ad infinitum. After 60 seconds, at the end of the experiment, how many ping-pong balls remain in the barrel?

The normative resolution to the Ping-Pong Ball Conundrum involves coordinating three infinite sets: the in-going ping-pong balls, the out-going ping-pong balls, and the intervals of time. In order to make sense of the resolution to this paradox, an understanding of actual infinity (described below) is necessary. Although there are more in-going than out-going ping-pong balls at each time interval, at the end of the experiment the barrel will be empty. An important aspect in the resolution of this paradox is the one-to-one correspondence between any two of the three infinite sets in question. Given these equivalences, at the end of the experiment, the same amount of ping-pong balls went into the barrel as came out. Moreover, since the balls were removed in order, there is a specific time for which each of the in-going balls was removed. Thus the barrel is empty at the end of the 60 seconds.

## BACKGROUND

A prominent trend in the studies regarding understandings of infinity has been to examine learners' conceptions through a lens of Cantorian set theory (e.g. Dreyfus & Tsamir, 2004; Fischbein et al., 1979). That is, students were presented with numeric sets, such as  $N = \{1, 2, 3, \dots\}$  and  $E = \{2, 4, 6, \dots\}$ , and were asked to draw cardinality (or "size") comparisons. Their conceptions have then been analysed based on the techniques or principles they apply to the task. In a recent study, Tsamir and Tirosh (1999) observed that the presentation of infinite sets had an impact on high school students' ideas as they compared the cardinality of those sets. For example, if the sets  $N$  and  $E$  were presented side-by-side, students tended to respond that  $N$  was the larger set since  $E$  was contained within it (the "part-whole" method of comparison). Whereas if  $N$  and  $E$  were presented one above the other the tendency was to draw a one-to-one correspondence between each number and its double and thus conclude that the sets were equinumerous. The irrelevant aspect of where on the page the sets are positioned illustrates what Fischbein et al. described as the "highly labile" nature of the intuition of infinity (1979, p.32).

An extensive literature review has revealed that only a few studies examine learners' conceptions of infinity through a lens other than that of numeric sets. Fischbein et al. (1979), as well as Fischbein, Tirosh, & Melamed (1981), for instance, are among the only studies to engage participants in analysing geometric sets, such as the set of points in a line segment or square. Despite the popular focus towards numeric representations of sets, investigating conceptions through this lens has limitations associated with the abstract nature of Cantorian set theory. Cantor's method of quantifying an infinite set  $M$  involved abstracting from the particular numbers of  $M$  to identify each with a "unit." He defined the cardinality of  $M$  as "a definite aggregate [or "set"] composed of units, and this number has existence in our mind as an intellectual image or projection of the given aggregate  $M$ " (Cantor, republished in 1955, p.86). In other words, by projecting each element of a set  $M$  to an abstract unit, Cantor focused on the magnitude of sets without the distraction of the particular

elements in the set - a distraction that misled many of his predecessors. This set of units was then quantified to describe the “size” of the set  $M$ , that is, to define its cardinality. Research regarding students’ understanding of Cantorian set theory suggests the abstraction to “units” is problematic; this is demonstrated, for example, by students’ use of the “part-whole” method (e.g. Dreyfus & Tsamir, 2004; Fischbein et al., 1979). Our study broadens research pursuits by exploring students’ naïve and emerging conceptions of infinity in a less abstract context: via their engagement with paradoxes.

## **THEORETICAL PERSPECTIVES**

We use two interrelated frameworks to interpret students’ intuitions, as well as their ideas of infinity after instruction: reducing abstraction (Hazzan, 1999) and APOS: Action, Process, Object, Schema (Dubinsky & McDonald, 2001).

In Hazzan’s (1999) perspective, reducing the level of abstraction of a mathematical entity occurs as a learner attempts to make sense of unfamiliar and abstract concepts. For instance, Hazzan describes the use of familiar procedures to “cope with new concepts” (1999, p.75) as a way to reduce the level of abstraction of a new problem. In the context of infinity, an example of reducing the level of abstraction might involve students’ use of familiar number properties to make sense of transfinite arithmetic. Hazzan further suggested that attempts to lower the level of abstraction of a mathematical entity are indicative of a process conception of that entity. Process and object conceptions of mathematical entities are described in the second framework considered in this study: that of the APOS (Action, Process, Object, Schema) theory (Dubinsky & McDonald, 2001).

Dubinsky, Weller, McDonald, & Brown (2005) proposed an APOS analysis of conceptions of infinity. They suggested that interiorising infinity to a process corresponds to an understanding of potential infinity, while encapsulating to an object corresponds to actual infinity. In the case of the Ping-Pong Ball Conundrum, the process of halving the remaining time intervals ad infinitum describes potential infinity. Conversely, actual infinity entails the completed infinite process and describes the set of time intervals as a whole entity existing within the 60 seconds. Dubinsky et al. suggested that encapsulation occurs once one is able to think of infinite quantities “as objects to which actions and processes (e.g., arithmetic operations, comparison of sets) could be applied” (2005, p.346). Dubinsky et al. also suggested that encapsulation of infinity entails “a radical shift in the nature of one’s conceptualisation” (2005, p.347) and might be quite difficult to achieve.

In terms of APOS theory, Hazzan argued that a “process conception of a mathematical concept can be interpreted as on a lower level of abstraction than its conception as an object” (1999, p.80). Extending these ideas, our study uses APOS theory to interpret students’ naïve and informed ideas, as well as their attempts to reduce the level of abstraction of infinity as they engaged in the Ping-Pong Ball Conundrum. Specifically, we address the following questions: (1) How do university



students respond to the Ping-Pong Ball Conundrum? (2) In what ways do responses differ with mathematical background? (3) What specific features of the problem are challenging for students?

## SETTING AND METHODOLOGY

This study surveyed 36 university students; 16 were practicing high school mathematics teachers enrolled in a graduate program in mathematics education, while the remainder were undergraduate students in liberal arts and social sciences with no mathematical background beyond high school. A similar approach of engaging students with the paradox was used in both groups. The study began by presenting participants with the Ping-Pong Ball Conundrum as a thought experiment and asking them to record their ideas individually. Group and class discussions ensued and were followed by formal instruction on cardinality and infinite sets. The instructional tasks included comparing infinite countable sets using one-to-one correspondence, or “coupling.” The conventional mathematical solution was presented and explained. Students then were asked to readdress in writing the original question - At the end of the experiment, how many ping-pong balls are left in the barrel? Students’ individual written responses as well as their arguments presented during the discussion were analysed, identifying the emergent themes.

## RESULTS AND ANALYSIS

Despite the varied levels of mathematical background and skill amongst the participants, there was no major difference in the responses from the different groups. Students’ initial solutions to the possible number of balls remaining in the barrel at the end of the 60 seconds can be clustered around two main claims, focusing on the rates of change and the possibility of ending the experiment, respectively:

There are infinitely many balls left in the barrel; and

The process is impossible since the time interval is halved infinitely many times, so the 60 seconds never ends.

### Students’ Responses Before Instruction: Rates of Infinity

The argument that infinitely many balls remain in the barrel was most frequently justified by appealing to the different rates of in-going and out-going balls: at each time interval 10 balls go into the barrel, but only one is removed. Nine out of 20 undergraduates (45%) and 13 out of 16 graduate students (81%) reasoned that the number of balls remaining in the barrel must be a multiple of nine or “ $9\infty$ .” Stan, an undergraduate student, explained:

There is  $9\times$  more balls in the barrel than out of the barrel at all times. At the end of the 60 seconds there are  $9\infty$  balls in and  $\infty$  balls out.

The notion of different rates of infinities seems to extrapolate common (finite) experiences with rates of change. As Stan observed, at every  $n$ -th time interval,  $9n$  balls remain in the barrel. This is consistent with the observation that students’ conceptions of infinity tend to arise by reflecting on their knowledge of finite

concepts and extending these familiar properties to the infinite case (Dubinsky et al. 2005; Dreyfus & Tsamir 2004; Fischbein 2001), and serves as an example of reducing the level of abstraction. According to Hazzan, this can be seen as the case of using familiar procedures to cope with novel and abstract concepts.

The rate argument might be a consequence of a process-oriented approach to resolving the Ping-Pong Ball Conundrum. In fact, the argument that the total number of in-going balls is 9 times larger than the number of out-going balls holds at every point in time; it fails only at the completion of the process at infinity.

### **Students' Responses Before Instruction: An Endless 60 Seconds**

Another conception of infinity surfaced as students addressed the possibility of a 'completed 60 seconds.' As Quine (1966) noted, during a person's attempts to resolve certain paradoxes regarding infinity, a "fallacy emerges [which is] the mistaken notion that an infinite succession of intervals of time has to add up to all eternity" (p.5). This 'fallacy' highlights the distinction between potential and actual infinity. In terms of the ping-pong balls, conceiving of an inexhaustible experiment corresponds to potential infinity - a process, which at every instant in time is finite but which goes on forever (Fischbein, 2001). Whereas, actual infinity would describe the complete and existing entity of time intervals within 60 seconds, and which encompasses what was potential. The 'fallacy,' to use Quine's term, lies not in the conception of an endless infinite, but rather in conceiving of potential infinity when the entity is actually infinite.

The process conception of infinity expressed by the idea of an inexhaustible 60 seconds surfaced in the initial responses of 15 out of 20 undergraduate students (75%) and 3 out of 16 graduate students (18%). Participants reasoned that since the intervals of time could be continually divided to smaller and smaller amounts without reaching zero, the experiment would never end. This argument is exemplified in Kenny's statement:

Even with 1 second left we can still divide this amount of time into infinitely small amounts of time (if physics does not apply). Therefore, the experiment will continue into eternity and the number of [tennis] balls will be infinite in the barrel.

There are at least two points of interest in Kenny's remark. The first is related to the ideas of limits and series. Series and the limits of their corresponding sequences are fundamentally interconnected: limits are used in order to determine convergence, and convergence can be used in order to determine limits. A series  $a_0 + a_1 + \dots + a_n + \dots$  is defined as convergent if the sequence of its partial sums  $\{s_n\}$ , where  $s_n = a_0 + a_1 + \dots + a_n$ , is convergent and the limit as  $n$  tends to infinity of  $\{s_n\}$  exists as a real number. Otherwise, the series diverges. In Kenny's argument we identify a confusion of the convergent series of "infinitely small amounts of time" that sum to 60 seconds with a divergent series that "will continue into eternity." This confusion might stem from an informal understanding of limits as unreachable - a common conception of college students (Williams, 1991), and one that is linked to a process conception of infinity (Cottrill, Dubinsky, Nichols, Schwingendorf, Thomas, & Vidakovic, 1996).

The second interesting aspect of Kenny's argument lies in his conclusion that the barrel should be infinitely full. If the experiment were to go on endlessly, then at no moment will the barrel contain infinitely many balls; instead it will always (endlessly) contain a finite quantity of balls -  $9n$  balls. Kenny seems to hold a flexible conception of infinity: on one hand, infinity is viewed as endless, yet on the other hand, it is used to describe a large unknown quantity. These competing notions of infinity might be cognitive attempts to reduce the level of abstraction of infinity, and support the suggestion that an understanding of infinity depends both on "conjectural and contextual influence" (Fischbein et al., 1979, p.32).

### Students' Responses After Instruction

As mentioned, the instruction included the idea of comparison via one-to-one correspondence. Also, the normative resolution to the Ping-Pong Ball Conundrum was presented. Interestingly, the proportion of undergraduates who appealed to the rate argument in their responses increased by 20 percentage points after discussion. The graduate students participating in this study also found the argument for different rates coercive. Roughly two thirds of graduate students maintained this conception despite instruction.

As part of the instructional conversation, students were challenged to name a ball that remained in the barrel if indeed the barrel was not empty. This challenge was given in order to help shift the focus away from the process of inserting and removing balls, and toward the final result. However, there was an overwhelming intuitive resistance to the possibility of an empty barrel. For example, Kyle explained:

There is an infinite number of balls in the barrel, however it is impossible to name a specific ball. As soon as a number is chosen, it is possible to determine the exact time... that ball was removed... I can't name a numbered ball that remains but then I also couldn't tell you how many balls we began with because there were infinity. Since you are always adding more than you are taking out, you can move at lightning speed, and you have infinity time intervals, I believe the task never ends.

With regard to the quantity of ping-pong balls, Kyle seemed to treat infinity as a large unknown number that could be scaled, but that would always remain large and unknown, and hence "infinite." Kyle also concluded that experiment "never ends," that is, by imagining the experiment being carried out, 'infinite' is perceived as synonymous with 'never ending.'

Following instruction on cardinality equivalences, a quarter of the undergraduate students were able to explicitly construct a one-to-one correspondence between incoming and out-going balls. However, none of them understood the correspondence to mean the barrel would be empty - instead ideas of an infinitely full barrel persisted. For instance, Wendy wrote:

There are still infinitely many balls left in the barrel, because even though there is a one to one correspondence between the sets  $\{1, 2, 3, 4, \dots\}$  [and]  $\{9, 18, 27, 36, \dots\}$ , the rate at which you are putting in is more than you are taking out. So even if there are just as

many numbers in each set, they will never even out, because the process continues infinitely and you continue to put more in than you take out.

The inherent contradiction in Wendy's and similar responses went unnoticed.

Only 4 graduate students (out of 36 participants) suggested that the number of balls in the barrel was zero after instruction, but added a comment that pointed to the distinction between what they "learned" and what they "believed". Timmy, for example, conceded:

I can now entertain the idea that there are no balls in the basket (but I don't like it).

Likewise, Leopold commented,

If you don't think about one-to-one correspondences, the instinct is there are 9 left every time you take one out, so it's 9 infinity.

## CONCLUSION

Paradoxes have played an important role in the history of mathematics and mathematical thought. The cognitive conflict elicited by a paradox can be difficult for a learner to resolve, particularly when the resolution depends on notions that defy intuition, experience, and reality. Nevertheless, the impulse to resolve a paradox can be powerful motivation for a learner to refine his or her understanding of the concepts involved (Movshovitz-Hadar & Hadass, 1990). As learners attempted to resolve the Ping-Pong Ball Conundrum they faced the challenge of competing notions of infinity. The level of complexity created by the interplay of three infinite sets, along with the counter-intuitive (and unavoidable) boundedness of one of the sets, proved to be difficult for many students to overcome. While both graduate and undergraduate students expressed notions corresponding to a process conception of infinity, undergraduate students were more likely to attend to the temporal aspects of the experiment.

As students refined their responses, their focus shifted from arguments of endlessness to arguments involving rates of in-going and out-going balls. In accord with Fischbein et al. (1979), students' intuitions were resilient: there was no change in their instinct of a full barrel despite the acquisition of formal knowledge. Paradoxes of infinity exemplify the fact that "mathematical thinking often extrapolates beyond the practical experience [and intuitive understanding] of the individual" (Tall, 1980, p.1). The Ping-Pong Ball Conundrum served as a good tool to encourage discussion and elicit ideas that might be obstacles for adopting a "conventional" understanding of infinity. Further investigations will attend to the different conceptual challenges elicited by other counter-intuitive infinity related paradoxes.

## References

- Burger, E. & Starbird, M. (2000). *The Heart of Mathematics: An invitation to effective thinking*. Emeryville, California: Key College Publishing.
- Cantor, G. (1915). *Contributions to the Founding of the Theory of Transfinite Numbers*. Translated by P. Jourdain, reprinted 1955. New York, USA: Dover Publications, Inc.

- Cottrill, J., Dubinsky, E., Nichols, D., Schwingendorf, K., Thomas, K., & Vidakovic, D. (1996). Understanding the limit concept: Beginning with a coordinated process scheme. *Journal of Mathematical Behaviour*, 15, 167 – 192.
- Dreyfus, T. & Tsamir, P. (2004). Ben's consolidation of knowledge structures about infinite sets. *Journal of Mathematical Behavior*, 23, 271-300.
- Dubinsky, E. & McDonald, M. (2001). APOS: A Constructivist Theory of Learning in Undergraduate Mathematics Education Research. In D. Holton et al. (Eds.). *The Teaching and Learning of Mathematics at University Level: An ICMI Study*. Dordrecht, The Netherlands: Kluwer Academic Publishers.
- Dubinsky, E., Weller, K., McDonald, M. A., & Brown, A. (2005). Some historical issues and paradoxes regarding the concept of infinity: an APOS-based analysis: Part 1. *Educational Studies in Mathematics*, 58, 335-359.
- Fischbein, E. (2001). Tacit models of infinity. *Educational Studies in Mathematics*, 48, 309-329.
- Fischbein, E., Tirosh, D., & Hess, P. (1979). The intuition of infinity. *Educational Studies in Mathematics*, 10, 3-40.
- Fischbein, E., Tirosh, D., & Melamed, U. (1981). Is it possible to measure the intuitive acceptance of a mathematical statement? *Educational Studies in Mathematics*, 10, 3-40.
- Hazzan, O. (1999). Reducing Abstraction Level When Learning Abstract Algebra Concepts. *Educational Studies in Mathematics*, 40, 71-90.
- Movshovitz-Hadar, N., & Hadass, R. (1990). Preservice education of math teachers using paradoxes. *Educational Studies in Mathematics*, 21(3), 265-287.
- Quine, W.V.O. (1966). *Ways of Paradox and Other Essays*. Kingsport, USA: Random House, Inc.
- Tall, D. O. (1980). The notion of infinite measuring numbers and its relevance in the intuition of infinity. *Educational Studies in Mathematics*, 11, 271-284.
- Tirosh, D. & Tsamir, P. (1996). The role of representations in students' intuitive thinking about infinity. *Journal of Mathematical Education in Science and Technology*, 27, 33-40.
- Tsamir, P. & Tirosh, D. (1999). Consistency and representations: The case of actual infinity. *Journal for Research in Mathematics Education*, 30, 213-219.
- Williams, S. (1991). Models of limits held by college calculus students. *Journal for Research in Mathematics Education*, 22(3), 219-236.

# MATHEMATICS INSTRUCTION IN HIGH NEEDS NYC MIDDLE SCHOOLS

Michael Meagher

Brooklyn College - CUNY

Andrew Brantlinger

CUNY Graduate Center

*We examine the mathematics instructional practices and beliefs of novice, alternatively certified (AC), mathematics teachers in New York City (NYC). Using observational, interview and survey data we analyse the emerging and developing identities of teachers working in an urban context. Analysis examines teachers' practice in relation to the Workshop Model employed in many NYC public schools; students' beliefs about tracking and the effects of tracking on instruction; and teachers' views on what would constitute the "ideal" classroom.*

## **FOCUS**

The purpose of this paper is to examine the mathematics instructional practices and beliefs of novice, alternatively certified (AC), mathematics teachers in New York City (NYC). The New York City Teaching Fellows (NYCTF) program currently brings approximately 350 new mathematics teachers annually into NYC public school system. They are given a temporary license and begin teaching full time in NYC public schools after a six-week summer training in the "the basics." The majority of the Fellows begin teaching in "high needs schools," raising concerns for educational equity within New York State in terms of teacher quality as measured by teacher preparation and experience.

## **THEORETICAL FRAMEWORK AND LITERATURE**

Since the implementation of the *No Child Left Behind* law and its stipulation that every classroom must have a certified teacher, urban districts have scrambled to find certified, qualified mathematics teachers. Alternative routes to teaching have emerged as an effective way for urban districts to bridge the gap not met by traditional certification programs (Boyd, Grossman, Lankford, Loeb, & Wyckoff, 2006). The research on the effectiveness of alternative certified (AC) teachers versus traditionally certified (TC) teachers is inconclusive: some studies find TC teachers produce higher achievement gains than AC teachers (Darling-Hammond and Peters, 2002) and still others fail to find significant differences between the two groups (Goldhaber & Brewer, 2000).

In spite of this, evidence indicates that teacher quality is a major factor affecting student achievement (Darling-Hammond, 2000; Wayne, & Youngs, 2003). Teaching experience matters; teachers' effect on student achievement increases mainly during the first few years of their career (Rowan, Correnti, & Miller, 2002). However, in New York State, disproportionate numbers of urban students of color are taught by novice and often less qualified teachers than their wealthier white counterparts

(Lankford, Loeb, & Wyckoff, 2002). This problem is particularly acute in hard to staff areas such as mathematics where turnover is high (Ingersoll, 2000).

## **METHODS AND METHODOLOGY**

### **Study Context and Participants**

There are four university partners that provide Master's coursework for each 300+ cohort of mathematics Fellows. In our study we have survey, interview, and classroom observation data from mathematics Fellows at all four university partners. In this paper we present findings from data on mathematics Fellows who take coursework at Borough University (BU) (a pseudonym). BU has approximately 55 first-year and 55 second-year mathematics Fellows taking Master's courses. We have extensive survey data from approximate 85% of these AC teachers. In addition, three of the Fellows (two first-years and one second-year) are part of a case study project in which we examine their experience of the NYCTF program and their mathematics teaching in considerable depth.

### **Data Sources**

We used three data sources in the analyses discussed in this paper, namely: observational, interview, and survey data.

**Observational Data.** We collected data in the form of fieldnotes, videotape, and audiotape once or twice a month, throughout one full school year for a minimum of eleven 90-minute classes. The video and audio data allowed us to revisit our fieldnotes and include detailed records of classroom discourse at key instructional moments (e.g., when students exhibit confusion).

**Interview Data.** At the beginning and end of the school year we conducted extensive interviews with all three of our BU case study Fellows. Interview questions dealt with such things as the Fellows' educational backgrounds, ongoing Master's coursework at BU, and beliefs about teaching mathematics in NYC public schools. In addition, after each observation, we asked our case study teachers to reflect on the observed lesson.

**Survey Data.** We collected survey data from both first-years (n=55) and second-years (n=42) in the BU Program, over 95% and 80% of these two cohorts respectively. The design of the surveys, informed by the observational component of our study, allowed us to examine the representative nature of our case studies (e.g., their use of required textbooks and groupwork) and to gain aggregate data of the entire cohort.

### **Methods of Analysis**

**Fieldnote Analysis.** The coding scheme that we used to analyze our fieldnotes was produced collaboratively with a larger group of researchers who were also collecting data on mathematics Fellows attending other partnering universities. Our coding scheme for the fieldnotes included such codes as: classroom management, teacher math questions, and opportunity for meaning making. These codes allowed us to separate out data that were relevant to our research questions, namely, (1) what does

teaching look like in BU Fellows classrooms? And (2) what opportunities are there for students to problem solve and communicate their own mathematical ideas?

**Interview Analysis.** We conducted the interview analysis by repeated reading of each interview followed by a comparison and contrast of responses in the interviews in order to develop a set of codes. For the purposes of this paper, we separated out portions of the interviews that dealt with the Fellow's beliefs about the nature of mathematics and mathematics education.

**Survey Analysis.** Similarly to the interview analysis, we examined only the parts of the survey that directly addressed the Fellow's views of mathematics and mathematics education. This accounted for approximately one sixth of the survey. We compared the case-study responses to the entire BU cohort to get a sense of how representative their backgrounds, beliefs, and experiences were when compared with others in their university program.

## **SAMPLE DATA AND RESULTS**

### **Instructional Practice and the Workshop Model**

We found many instructional similarities across all three teachers. First and foremost, all three taught middle school mathematics using the standards-based "Workshop Model" of instruction which the the NYC Department of Education mandated for all teachers before the 2003-04 school year (Traub, 2003). The impact of the workshop model policy meant that we observed similar lesson structures in all three classrooms. In theory at least, the workshop model is progressive; it limits lectures and has teachers put students together in small groups for a "student work period." However, a closer examination of the instruction in these three Fellows classrooms reveals three distinctive, yet essentially teacher-centered, forms of pedagogy. All three gave explicit step-by-step instruction of the "right" method. After that they each assigned students problems which emphasize practicing of algorithms. When students struggled with problems, the three case study Fellows were quick to intervene so as to not allow students to get frustrated: the typical mode of this intervention was to break the problem down into small steps through a series of leading questions, e.g "They want you to change from kilometers to what? So you should divide by what?"

The survey data indicates that the majority (29 of 42) of the BU Fellows used the workshop model as their primary instructional mode. Thus, our case study Fellows were not atypical. Moreover, while most of the BU Fellows claimed to use the workshop model, only about half (22 of 42) agree or strongly agreed with the statement that the workshop model is an "effective" instructional model. 12 disagree or strongly disagreed with the notion with 7 remaining ambivalent. One of our three case studies also felt ambivalent about the workshop model. She wished she could seat students individually from time to time for classroom management purposes but felt administrative pressure not to do so.

While there were structural similarities, a comparison of the three case study Fellows reveals differences across the three teachers. One first-year Math Fellow



landed in, what she described as a particularly “difficult” school with an “inept” administration (her words in quotations). Unlike the other two Fellows, she was unable to pull her students together to review the in-class work that was assigned. The last 20 minutes of her 90-minute lessons generally diffused into student chatter. She also limited her “mini-lessons” to no more than ten minutes - apparently because she could not expect students to remain focused for longer periods of time. Indeed, she makes this clear in post-observation reflections. The other two case study Fellows presented much longer lectures and also typically brought the whole class together during the last 10 to 15 minutes of the class period to review the in-class problems that students worked on and often completed.

### **Beliefs about Tracking and the Effects of Tracking on Instruction**

Comparing fieldnotes from different classes of the same case study teacher also lead to interesting results. Two of the Fellows we observed taught different tracks of students - essentially “honors” and “remedial” tracks of students. While both Fellows essentially taught the same lesson to both tracks, there were qualitative differences in the nature of classroom discourses between high and lower track classes. As one might expect (Oakes, 2005), student resistance and teachers use of explicit disciplinary discourses was greater, more explicit, and more pronounced in the lower track classes. One of the case studies described his relationship with his honors students as “close” whereas his relationship with his regular track students was strained (our word) - at the end of the year one regular track student told him, “you should work on being less grumpy” for the upcoming year.

The survey data suggests that most BU Fellows do not teach “honors” classes in their first year. Thus, in this respect, our case study Fellows were atypical. However, similar to our case studies, many BU Fellows reported teaching regular and remedial courses - that is, students in different tracks. In interviews, the three case study Fellows support tracking. It should be noted that, like many of their BU counterparts, all three were in “honors” or “gifted programs” when they were in school so it is, perhaps, not surprising that they support tracking. On another survey item, the vast majority of BU Fellows responded that they were much more likely to give students who test above grade level opportunities to “explore unfamiliar mathematics problems” and “to develop their own hypotheses” than students who test below-grade level (e.g. students in lower track courses.) This survey response is somewhat unclear when we consider our observational data: while there were qualitative differences in discourse (more or less management focused) and participation (more or less resistant) between lower and higher track classes, we observed very little explorations and student-centered hypothesis making in any of our classes even those classified as “honors.”

### **The “Ideal” Class**

Our interviews and surveys also touched on other aspects of teaching and learning mathematics. In particular, when we asked the BU Fellows to describe “effective

mathematics teaching” in the surveys and interviews we got a range of responses. The most commonly expressed theme was a desire to make the mathematics relevant to the students’ lives. That is, effective teaching was engaging because it was “real world” relevant or related to student interests. The second most common theme was that effective teachers had built strong relationships with their students. Achieving such relationships is a challenge for the Fellows in light of the fact that they are typically taking classes as part of their Master’s coursework two to three nights a week. The Fellows do not generally live in the same geographical area of the school and state in interviews and surveys that there has not been much opportunity to build relationships with students, parents or other stakeholders in the school community. When we asked them about their beliefs about the amount of emphasis they would place on teaching concepts and procedures, over 85% claimed that they would strike a balance between teaching concepts and procedures. Our case studies responded similarly. Yet, our observations revealed that, by and large, their instructional focus was heavily procedural.

## References

- Boyd, Grossman, Lankford, Loeb, & Wyckoff (2006). *How Changes in Entry Requirements Alter the Teacher Workforce and Affect Student Achievement*. American Education Finance Association.
- Darling-Hammond & Peters (2002). Defining “Highly Qualified Teachers”: What Does “Scientifically-Based Research” Actually Tell Us? *Educational Researcher*, 31(9), 13-25.
- Darling-Hammond, L. (2000). Reforming Teacher Preparation and Licensing: Debating the Evidence. *Teachers College Record*, 102(1), 28-56.
- Darling-Hammond, Berry, & Thoreson (2001). Does Teacher Certification Matter? Evaluating the Evidence. *Educational Evaluation and Policy Analysis*, 23(1), 57-77.
- Goldhaber, D. D., & Brewer, D. J. (2000). Does Teacher Certification Matter? High School Teacher Certification Status and Student Achievement. *Educational Evaluation and Policy Analysis*, 22(2), 129-145.
- Lankford, H., Loeb, S., & Wyckoff, J. (2002). Urban Schools: A Descriptive Analysis. *Educational Evaluation and Policy*, 24(1), 37-62
- Oakes, J. (2005). *Keeping Track: How Schools Structure Inequality*, 2nd Edition. New Haven, CT: Yale University Press.
- Rowan, Correnti, & Miller (2002). What large-scale survey research tells us about teacher effects on student achievement: Insights from the Prospects study of elementary schools. *Teachers College Record*, 104, 1525-1567.
- Traub, J. (2003). *New York's New Approach*. New York Times. (August 03, 2003)
- Wayne, A. & Youngs, P. (2003). Teacher Characteristics and Student Achievement Gains: A Review. *Review of Educational Research*, 73(1), 89-122.



# INSTRUCTORS' LANGUAGE IN TWO UNDERGRADUATE MATHEMATICS CLASSROOMS

Vilma Mesa and Peichin Chang

University of Michigan

*We report an analysis of the language used by two instructors teaching two undergraduate mathematics classes that exhibited high student participation but that upon a more detailed analysis of language of engagement differed substantially in the level of dialogical engagement. This linguistic analysis offers an alternative lens to study the level of engagement of instructors and students in classroom interaction that complement studies that focus on the role of language on students' learning. We discuss implications for research and for faculty development regarding managing classroom interaction.*

Calls for increasing student participation in mathematics classroom from K-12 settings (e.g., National Council of Teachers of Mathematics [NCTM], 2000) have been promoted also at the tertiary level (Blair, 2006). In a setting in which lecturing seems to be the dominant mode of interaction between students and instructors (Lutzer *et al.*, 2007) what instructors can do to increase participation seems difficult to implement. In this paper we argue that we need to refine the lenses by which we analyze classroom interaction to attend to the ways in which instructors use *words* to engage or disengage students from the dialog. This type of analysis might prove useful in also devising ways to assist college instructors in changing the dynamics of classroom activity in mathematics.

## LITERATURE REVIEW

Articles reporting analyses of classroom discourse in *undergraduate science and mathematics education* classrooms have taken a position that the social context matters for learning. Under this position, learning is both an individual and social process, and both occur co-dependently. The analyses provide rich descriptions of both students and instructors' activities in the classroom with the ultimate goal being to describe the nature of learning that happens with given tasks in that particular context (see e.g., Cochran, 1997; Stephan & Rasmussen, 2002). Studies in *higher education* look at classroom interaction to uncover patterns of participation that might exclude some groups and highlight the role that instructional practices have on the interaction patterns. The "chilly climate" hypothesis, for example, refers to patterns of interaction that occur in college classrooms that prevent females or minorities from participating actively (by asking questions or offering answers) and that lead them to leave or change degrees for which they are highly qualified (Fassinger, 2000; Hall & Sandler, 1982; Williams, 1990). Finally studies from the *linguistics* literature with undergraduate settings are limited to analyses of academic registers, both oral and written, using large corpora of data (full textbooks or

collections of classroom lectures). The analyses investigate uses given to specific words and expressions (e.g., ‘point,’ ‘no way,’ Swales, 2001) with contrasts across disciplines. Although these studies are important, especially for teachers of English, it is not clear that they are useful for understanding classroom interaction. Linguistic analyses of undergraduate classroom interaction are virtually non-existent.

These analytical approaches to studying classroom interaction attend to language but with an eye to understanding how the learner use of it (either by participating or by understanding mathematics). What is lacking from these studies is an analysis of what *instructors’* language in particular academic disciplines looks like and of the kinds of positions they convey when managing classroom interaction. Given the calls for increasing such interaction in the undergraduate mathematics classroom, understanding how the language of the interaction works in this setting seems crucial to assist instructors who are interested in changing their interaction patterns in teaching. An analysis of the linguistic devices that instructors use to engage students in the dialog is an important contribution towards understanding how interaction can be fostered in undergraduate mathematics classrooms.

## METHODS

We use Martin and White’s (2005) engagement system that suggests that interpersonal meanings are realized in the interplay of two discursive voices, *monogloss* and *heterogloss*. Informed by Bakhtin’s/Voloshinov’s notions of “dialogism and heteroglossia,” the engagement system regards all utterances as dialogic, suggesting that what is said is invariably implicated in a web of references (Martin & White, 2005, p. 93). Bakhtin (1981) elucidates that all utterances exist

against a backdrop of other concrete utterances on the same theme, a background made up of contradictory opinions, points of view and value judgments... pregnant with responses and objections (p. 281).

Based on this notion, engagement analysis investigates “the degree to which speakers/writers acknowledge these prior speaking, ... whether they present themselves as standing with, as standing against, as undecided, or as neutral with respect to these other speakers and their value positions” (Martin and White, 2005, p. 93). The engagement framework aims to provide a “*systematic* account of how such positionings are achieved linguistically” (p. 93, emphasis added).

*Monogloss* is defined as akin to “bare assertions” in which no “dialogistic alternatives” are needed to be recognized (p. 99). It designates an inherent value of taken-for-grantedness and presupposition that allows little room for advancing a counter point. Monogloss construes propositions that do not need to be brought into active rhetorical play and are therefore construed as self-evidently right and just. Such text often sounds descriptive, report-like, and impersonal. By comparison, *heterogloss*, overtly grounds the proposition “in the contingent, individual subjectivity of the speaker/writer” and thereby recognizes that the proposition is but one among a number of propositions available (p. 100). From our data, we provide

examples (Figure 1) to illustrate how each discursive voice is realized linguistically. Key linguistic items are underlined to highlight the discursive effects of each voice.

<p>Monogloss</p> <ol style="list-style-type: none"> <li>1. <u>So what we have to do is</u> compare 2006 dollars to 2006 dollars.</li> <li>2. ... <u>ask yourself</u> how does that procedure you use generalize.</li> <li>3. So <u>the input here is</u> <math>y</math>.</li> <li>4. <u>That accounts for</u> the fact that <u>they're</u> power series.</li> </ol> <p>Heterogloss</p> <ol style="list-style-type: none"> <li>5. For Taylor series <u>I think</u> it's fine to write <math>S_1(x)</math>, <math>S_2(x)</math>.</li> <li>6. Ok, <u>but</u> we want to compare the current federal minimum wage, which is by definition 200...</li> <li>7. <u>Why don't you</u> use the ten-minute rule...</li> <li>8. Then how does the volume change, <u>if</u> you add an inch of radius then?</li> <li>9. <u>I would be</u> very interested to see an anti derivative for <math>e</math> to the <math>-t^2</math>.</li> <li>10. This is the part that changes <u>when</u> the point about which you expand <math>x</math> changes, changes.</li> </ol>
--

Figure 1. Examples of monoglossic and heteroglossic discursive voices.

In the four monogloss examples, no dialogistic alternatives are needed to be recognized. They construe propositions that are self-evidently right and just (“ask yourself...,” “So the input... is...”). The speakers therefore do not seek to engage the listeners but merely state things as they are. Heterogloss is marked by authorial interpolation and engages the speakers interpersonally. In Example 5 in interpolating the authorial subjectivity “I think,” the speaker, instead of construing the proposition as self-evidently right, foregrounds his opinion as confined in his very subjectivity, which can therefore be subjected to re-examination. Grounding the proposition in the contingent individual subjectivity of one speaker admits that the proposition is but one among a number of propositions available. In Example 6, by posing the statement in the countering “but,” the speaker seeks to restrict the scope of dialogic possibility in foregrounding his more assertive claim. “But” is used to counter a previous utterance to highlight the current statement as more appropriate or reliable. It therefore contracts dialogic possibility by a more assertive stance. In comparison to the more assertive claims, in Example 4, the conditional “if” renders the statement tentative and thus invites more dialogic possibilities. It opens up room for further discussions that may lead to multiple interpretations. In Example 9, the speaker, in uttering “I would be very interested,” expresses his inclination in modal term. Usually “I would be” comes with conditional phrases “if” which can rest the claim on more tentative ground. Contrary to “I am interested” which states more of a solid fact that concedes no contestation, “I would be interested” expresses more of an inclination that would stand true if some other conditions are met.

In addition, we can choose to heteroglossically contract or expand an argument, depending on “the degree to which an utterance... actively makes allowances for dialogically alternative positions and voices (dialogic expansion), or alternatively, acts to challenge, fend off or restrict the scope of such (dialogic contraction)” (p. 102). *Contraction* is directed toward confronting and defeating potential contrary positions in asserting or insisting, whether explicitly or implicitly, seeking to align readers to the author’s point of view (Koutsantoni, 2004, p. 164). Its two main features are “*disclaim*” and “*proclaim*.” *Disclaim*, is used mainly to reject prior utterances or alternative perspectives by denying and countering. *Proclaim*, on the other hand, is used to overtly announce agreement with the projected dialogic partner by concurring, pronouncing, and endorsing. In proclaiming, the author simultaneously designates other interpretations or perspectives as less valid, thus contracting the argument to align the readers to his or her side. *Expansion* concerns an authorial voice set to entertain alternatives and possibilities as claims still open to question. Its two main features are “*entertain*,” and “*attribute*.” *Entertain* generally softens an otherwise subjective statement by a variety of linguistic resources such as modal auxiliaries (may, might), modal adjuncts (perhaps, probably), modal attributes (it’s likely that), circumstances (unless, when), mental verb/attribute projections (I believe, I suspect that), ‘evidentials’ (seem, apparently), and (7) questions. *Attribute* includes “*acknowledge*” and “*distance*” (Martin & White, 2005, p. 105ff).

### **Sampling**

From a corpus of 11 college mathematics classes audiotaped for a different project we selected those in which the ratio of students’ utterances to that of the instructor’s was at least 1. Lesson A was taken from a general education requirement course that covers topics such as linear equations, linear programming, linear regression, probability, and statistics for non-math or science majors. The instructor, a male, junior faculty with about 5 years of teaching experience, dedicated the first part of the class to let students work in groups on a worksheet with problems of a higher complexity than those in their textbooks. The observation was done in Winter 2007 about 6 weeks into the 14 weeks course, when it was thought that most norms for classroom interaction had been established. The purpose of this lesson was to apply strategies to convert nominal to real dollars (and vice versa) for different years. For the first 24 minutes, when most of the interaction occurred in this 90-minute class, students worked in small groups solving six problems. Lesson B was taken from an elective course that seeks to engage first-year non-honors students interested in math or science in learning to solve calculus mathematics problems. For each session, the instructor (a male, junior faculty with about 7 years of teaching experience) created a worksheet and after assigning the students to small groups of 3 or 4, let them work on their own, listening and intervening as needed. The lesson was recorded in October 2006, 5 weeks after the beginning of the term. For the first 24 minutes of this two-hour class students worked on three of the 10 assigned problems. In both classes the problems admitted more than one solution strategy and were considered challenging.

## Analysis

The focus of the analysis was the instructors' utterances. We counted the turns and then parsed all instructors' turns into clauses.<sup>1</sup> Each clause was coded using the categories of engagement defined previously. The second author parsed and coded both transcripts in consultation with the first author. During these consultations we refined the categorization and tested the consistency and reliability of the coding system. The level of agreement and consistency ranged from 70% to 96% and therefore, the coding was deemed reliable; we used the coded transcripts for the analysis.

## RESULTS

In the 24-minute segments analyzed the ratio of students' turns to instructor's turns was 1 in Class A and 1.5 in class B. Class A had 309 clauses, whereas Class B had 73. In Class A, 157 (51%) of the clauses were monoglossic whereas in class B only 25 (34%) were monoglossic. In Class A, 90 of the 147 heteroglossic clauses were expanding, whereas in Class B 34 of the 44 heteroglossic clauses were expanding. We present two short excerpts that are representative of the engagement observed in the two classes (The coding is in parenthesis).

- |     |           |   |
|-----|-----------|---|
| 1.  | <b>S:</b> | I, ok, I did this percent increase. I did it the way you always tell us to do it and I got the wrong answer.  |
| 2.  | <b>I:</b> | Ok.   |
| 3.  | <b>S:</b> | I did it...   |
| 4.  | <b>I:</b> | <u>How do</u> you know the answer's wrong? ( <b>Heterogloss Expanding-Entertaining: Question, HE-En:Q</b> )   |
| 5.  | <b>S:</b> | Well because um, I got 10% and that's not right because I plugged into the equation and I got a wrong answer.                                       |
| 6.  | <b>I:</b> | Ok. Well...   |
| 7.  | <b>S:</b> | It's supposed to be $\text{new} = (1 + r) \text{ times old}$ .  |
| 8.  | <b>I:</b> | <u>That's</u> if it's an increase. (Monogloss, M)   |
| 9.  |           | <u>Is it</u> actually an increase? (HE-En: Q)   |
| 10. |           | <u>You're</u> comparing here... (M)   |
| 11. | <b>S:</b> | Well the minimum wage was \$3.35 and it was \$5.45.   |
| 12. | <b>I:</b> | Ok. <u>But</u> you're trying to compare two things that are in different units. ( <b>Heterogloss Contracting-disclaim-counter, HC-dis-counter</b> ) |
| 13. |           | <u>This is</u> in 1989 units, (M)   |
| 14. |           | <u>this is</u> in 2006 units. (M)   |
| 15. |           | <u>You can't</u> compare things that are in two different units. ( <b>Heterogloss Contracting-disclaim-deney, HC-dis-deney</b> )                    |
| 16. |           | <u>You have to</u> compare 2006 dollars to 2006 dollars. (HE-En-modality)   |

### Excerpt from Class A

<sup>1</sup> A *clause*, from the perspective of Functional Grammar, is a better unit than sentence for analysis because a clause may contain rich information that the writers or speakers use to good effect whereas sentences may have variance considering their unequal grammatical contributions to the text. Therefore, the clause is "the best basic unit of grammatical analysis of text" (Schleppegrell, 2008, p. 551).



In this example, the instructor responded to the student's inquiry by a how-question seeking clarification to why the student deemed his answer wrong (line 4). After responses from the student, he offered explanation by a statement, "That is if..." followed by a yes-no question, "Is it...?" (lines 8-9). More information was to be given next as a statement though interrupted by the student) and then by a countering "But" to point out the problem the student was encountering, "But you're trying to..." (lines 10-12). The explanation went on using statements and a denying "can't" (lines 13-15) and a direct command 'you have to' (line 16).

- |     |           |   |
|-----|-----------|---|
| 1.  | <b>I:</b> | Then <u>how</u> does the volume change, (HE-en: Q)                          |
| 2.  |           | <u>if</u> you add an inch of radius then? (HE-en: Conditional)              |
| 3.  | <b>S:</b> | The volume gets larger.   |
| 4.  | <b>I:</b> | The volume what? (HE-en: Q)   |
| 5.  | <b>S:</b> | Gets larger.  |
| 6.  | <b>I:</b> | Right, ( <b>HContracting-proclaim-concur</b> )                              |
| 7.  |           | by how much? (HE-en: Q)   |
| 8.  | <b>S:</b> | Oh. It depends on what your radius is.                                      |
| 9.  | <b>I:</b> | Right. (HC-pro-concur)  |
| 10. |           | <u>But what's</u> the quantity? (HC-dis-counter)                            |
| 11. | <b>S:</b> | $4\pi r^2$ . You're asking me for the big picture?                          |
| 12. | <b>I:</b> | Yes. (HC-pro-concur)  |
| 13. |           | And so <u>what I'm asking you</u> is (M)                                    |
| 14. |           | <u>does</u> the volume change by exactly $4\pi^2$ , $4\pi r^2$ ? (HE-en: Q) |
| 15. | <b>S:</b> | Yes. Approximately $4\pi r^2$ ?   |
| 16. | <b>I:</b> | Approximately or exactly? (HE-en: Q)  |

Excerpt from Class B

In this example the instructor first asked a how-question framed in a condition (lines 1-2), "if...then." He raised further questions by asking the student to specify "by how much" the volume changes (line 7). When the student responded with a more general observation, he rephrased the same question as "But what's the quantity?" to get the student to focus on the "big picture" (lines 10-12). "But" in this question was emphatic in drawing the student's attention to stay on the question. In other words, it highlighted the question in concern for the student. After a few rounds of inquiring and responding, the instructor next framed the question more specifically by building on the answers the student had responded earlier, "does the volume change by exactly  $4\pi^2$ ,  $4\pi r^2$ ?" (line 14) with the next question meant to be to point out a second important aspect of the question, whether the change is being calculated or estimated (l. 16).

Compared to students in class A, students in class B were asked more questions or offered more suggestions than contracting or informational statements. In class A, students asked questions and were responded by more definitive explanations or

information which did not explicitly prompt them to think but that geared them towards the instructor's agenda. By varying discursive strategies as exemplified by these two instructors, students got to respond, and probably think, differently depending on how the instructors responded using the discursive options they deemed appropriate.

## **DISCUSSION**

The analysis lets us trace features of the language that distinguish how instructors engage students in the dialog. First, the analysis reveals that monologic discourse is somewhat prevalent within interactive segments of a class, which suggests that stating facts that presumably need to be learned is an important aspect of academic instruction in mathematics. Second, the analysis reveals that within heteroglossic discourse entertaining and contracting forms are also used to give information, assess situations, and to seek explanations and information from the students. We see how tentative language is used to counteract the authoritarian voice of the instructor in the setting. Authoritarian voice is being recognized as a feature of mathematics, ostensibly present in textbooks (Herbel-Eisenmann, 2007; Love and Pimm, 1996). Third, we found striking differences in how the two instructors positioned themselves with respect to their students. To an external observer, the two classes will appear to engage students actively with the material being discussed—a practice that has been suggested as fundamental for ensuring students' learning in undergraduate mathematics classrooms (Blair, 2006). The presence of monologic speech (51% and 34% in Class A and Class B, respectively) suggests that stating facts is a need for a problem solving session to be sustained and that these two instructors were the source of a substantial number of those facts. However, the different levels at which the two instructors invite students into the dialogic practices suggest that a deeper look at the quality of the engagement is crucial.

### **Concluding remarks**

Raising awareness of the role of language in sustaining dialogic engagement is an important area for research and for faculty development. We showed that even in a seemingly highly interactive setting, there might be little room for students to include their own perspectives or voices into the dialog but that it is possible, however, to organize discourse in a way that does. Some analysis of how instructors' language invites students into the dialog seems to be an important area for consideration. While awareness about students' misconceptions has been highlighted as important for future faculty (Speer *et al.*, 2005), information about the impact of language in the classroom work is also important for all instructors. We use language to deliver information and to assess students' progress. How we use it conveys powerful messages that might exclude the students that we need to be participating in the dialog.

### **References**

Bakhtin, M. M. (1981). *The Dialogic Imagination*. Austin, TX: University of Texas Press.

- Blair, R. (Ed.). (2006). *Beyond Crossroads: Implementing Mathematics Standards in the First two Years of College*. Memphis, TN: American Mathematical Association of Two Year Colleges.
- Cochran, J. P. (1997). What's 'common' in a common core: How course structure shapes disciplinary knowledge. *Journal of Classroom Interaction*, 32, 45-55.
- Fassinger, P. (2000). How classes influence students' participation in college classrooms. *Journal of Classroom Interaction*, 35(2), 38-47.
- Hall, R. M. & Sandler, B. R. (1982). *The Classroom Climate: A Chilly One for Women?* Washington DC: Project on the Status and Education of Women, Association of American Colleges.
- Herbel-Eisenmann, B. (2007). From intended curriculum to written curriculum: Examining the "voice" of a mathematics textbook. *Journal for Research in Mathematics Education*, 38, 344-369.
- Koutsantoni, D. (2004). Attitude, certainty, and allusions to common knowledge in scientific research articles. *Journal of English for Academic Purposes*, 3, 163-182.
- Love, E. & Pimm, D. (1996). 'This is so': A text on texts. In A. J. Bishop, K. Clements, C. Keitel, J. Kilpatrick, & C. Laborde (Eds.), *International handbook of mathematics education* (Vol. 1, pp. 371-409). Dordrecht: Kluwer.
- Lutzer, D. J., Rodi, S. B., Kirkman, E. E., & Maxwell, J. W. (2007). *Statistical Abstract of Undergraduate Programs in the Mathematical Sciences in the United States: Fall 2005 CBMS Survey*. Washington, DC: American Mathematical Society.
- Martin, J. R. & White, P. R. R. (2005). *The Language of Evaluation: Appraisal in English*. New York: Palgrave-Macmillan.
- National Council of Teachers of Mathematics [NCTM]. (2000). *Principles and Standards for School Mathematics*. Reston, VA: Author.
- Schleppegrell, M. (2008). Grammar, the sentence, and traditions of linguistic analysis. In C. Bazerman (Ed.), *Handbook of Research on Writing*. New York: Erlbaum.
- Speer, N., Gutman, T., & Murphy, T. J. (2005). Mathematics teaching assistant preparation and development. *College Teaching*, 53, 75-80.
- Stephan, M. & Rasmussen, C. L. (2002). Classroom mathematical practices in differential equations. *Journal of Mathematical Behavior*, 21, 459-490.
- Swales, J. (2001). Metatalk in American academic talk: The cases of point and thing. *Journal of English Linguistics*, 29, 34-53.
- Williams, D. (1990). Is the post-secondary classroom a chilly one for women? A review of the literature. *The Canadian Journal of Higher Education*, 20(3), 30-42.

# EXEMPLIFICATION IN TEACHING CALCULUS

Nikolaos Metaxas

University of Athens

*Many studies speculate on the content knowledge for teaching building on Shulman's pedagogical content knowledge. We examine the way that specialized and pedagogical content knowledge apply in the case of teaching calculus through the study of use of examples and what we call content meta-examples.*

## INTRODUCTION

In 1986 Schulman identified three domains of teacher knowledge that are content-related: content knowledge that includes knowledge of the subject and its organizing structures, curricular knowledge and pedagogical content knowledge (Grossman, Wilson, & Sculman, 1989; Schulman, 1986; 1987). It was a breakthrough to consider content and its role in instruction and these three categories comprise what Schulman (1986) referred to as the missing paradigm in research. Over the course of Schulman's research group work, the categories underwent a number of revisions while at the same time many researchers exploited the fertile ground analyzing the content knowledge for teaching and its categories. Still little progress has been made on developing a coherent theoretical framework as Schulman had hoped for due mainly to the lack of definition of key terms. For example pedagogical content knowledge (P.C.K) is defined by Niess (2005) as intersection of knowledge of the subject with knowledge of teaching and learning, by An, Kulm, & Wu (2004) as the knowledge of effective teaching that includes three components, knowledge of content, knowledge of curriculum and knowledge of teaching, and by de Berg and Greive (1999) as a product of transforming subject matter into a form that will facilitate learning by students. By focusing on the "work of teaching", Ball and her group (Ball, & Bass, 2003) choose a different approach, that is practice based. In Ball, Thames, & Phelps (2007), mathematical knowledge for teaching is divided in two domains : subject matter knowledge and P.C.K. By further subdividing each category they give more easily a description of each subdivision's main characteristics. In this paper, using similar questions to that developed by Ball (Ball, Hill, & Bass, 2005) we focused on a specific item : examples of mathematical concepts and examples of teaching methods trying to relate them to the categorization of Ball.

## THEORETICAL PERSPECTIVE

The theoretical perspective is based primarily on Shulman (1986) and Ball et al. (2007). Schulman was the first to identify a special domain of teacher knowledge, which he termed *pedagogical content knowledge* (P.C.K) as the special mixture of content and pedagogy needed to teach the subject. In recent years an effort has been made by several researchers to provide a framework in order to specify and exploit the ideas introduced by Schulman and colleagues. In particular Ball distinguishes

between three types of subject matter knowledge : common content knowledge, specialized content knowledge (S.C.K) and horizon knowledge and three types of P.C.K: knowledge of content and teaching, knowledge of content and students and knowledge of content and curriculum. We believe that the mathematical tasks of teaching necessary for the S.C.K given in Ball et al. (2007) can not be transferred automatically in the case of calculus teaching in the secondary education. Finding an example to make a specific point which has been quite extensively explored mainly for grades 1-9 can be rather intriguing in the case of calculus teaching. We regard that the qualities involved in the process of finding and giving a good example in calculus concepts like continuity, differentiability and integration - for example richness, correctness, accessibility and generality (Zazkis & Leikin, 2007), transparency, specificity or generality of counterexamples - are usually of a very different nature and function than in more primary settings as fractions, functions or geometry. There are many pedagogic distinctions in bibliography that form different categories of the examples used : there are examples and illustrations (Sowder, 1980) which can be distinguished further between worked-out examples and exercises (Renkl 2002), there are also generic examples, counter-examples and non-examples (Bills, Dreyfus, Mason, Tsamir, Watson, & Zaslavsky, 2006), there are specific, general and semi-general counterexamples (Peled & Zaslavsky, 1997) just to name a few. Although the above distinctions focus on the mathematical examples a teacher would give on a specific area of mathematics, we regard equally important the ability of a teacher to give easily examples of mathematical concepts or definitions where a particular pedagogical method is used. By asking a teacher to give an example of a topic that has an interesting connection to a non-mathematical subject, or of a concept that he can use it to emphasize the conflict that could occur between intuition and a formal proof, or of a topic that he is using a different teaching approach than the one suggested by the book, we can spot some aspects of teacher's pedagogical knowledge K.C.S and K.C.T. We call these examples that penetrate all three basic forms of knowledge S.C.K, K.C.S and K.C.T *content meta-examples* since they combine not only specific mathematical knowledge at a certain level, but their use can be explained and justified through arguments that show certain student and teaching knowledge.

## **METHOD**

This study is adjunct of a larger research concerning teachers' S.C.T, K.C.T and K.C.S types of knowledge that are formed after a graduate course of Calculus Didactics for secondary education teachers in Greece. During a semester six questionnaires were passed out to 15 teachers-graduate students. Each questionnaire consisted of 5 to 7 questions - problems that were designed to examine teacher's S.C.K , K.C.S and K.C.T. They focused on different aspects of teachers' knowledge and strategies like the ability to explain and correct students' misconceptions, engaging students in learning, their use of examples. The questions were spanned through the whole range of calculus that is taught at grade 12 in Greece and that

includes basic proof and logic theory, functions, limits of functions, continuity, differentiability and integration theory. Each teacher-student had to audiotape a “teaching session” and the discussion he had with a grade-12 student on a calculus topic. Finally the researcher had two interviews with each teacher during the first and the last week of the classes. In these interviews each teacher was asked to clarify several points of his answers in the questionnaires and of his sessions with his student. The focus of the interview questions was their use and understanding of examples and content meta-examples (Table 1). The semi-structured interviews had the goal of checking among others, the teacher’s accessibility, correctness, reachness and generality of examples or content meta-examples given and examining the student and teaching knowledge that is associated with these.

	S.C.K	K.C.S	K.C.T
Examples of a mathematical point	Correctness, reachness, generality of examples given	Does this example help to clarify students misconceptions?	At what point in the teaching sequence is she using it?
Content meta-Examples	Does he know to give an example of a specific topic that is subtly and profoundly connected to another math area?	-Why does she think her example is important regarding student learning ?	An example where he is using a different teaching sequence than the book

Table 1. Sample interview questions-points regarding knowledge relative to the use of examples and content meta-examples

## RESULTS

The purpose of this paper is to explore a modification of Ball’s classification of teacher’s knowledge in the realm of calculus teaching, through the study of exemplification. The use of examples and content meta-examples intersects all of the three categories S.C.K, K.C.S and K.C.T and sheds new light into mathematical knowledge for teaching. Space limitations only permit us to present results concerning two teacher-students and sketch the most critical points from the interviews. Teacher-student A, which has a 11 year long teaching calculus experience, answered correctly 22 out of the 30 mathematical questions in the questionnaires and demonstrated a satisfactory mathematical background. In his written responses he is using examples when introducing a new concept or definition (in particular in questions regarding inverse functions, continuous functions, Bolzano’s and Rolles’s theorem and l’Hospital’s rule he is giving lesson plans with introductory examples) and most of his examples in these cases are of the start-up and model type (Bills at al., 2006). Almost two thirds of them were repeated examples of how to carry out various procedures which are actually practice exercises. As he remarked in his

interview: “I often try when giving a definition or stating a theorem to provide some non-example or even a counterexample showing the limitations that follow the hypotheses...”. Nevertheless when asked to give a specific non-example or counterexample, he could only give the examples (or some alterations of these) that the book is providing. The following excerpt from his interview (about the theorem that a differentiable function on an interval is also continuous) is illustrative:

- R (interviewer) : Would you give any kind of example when introducing this theorem ?
- A : Yes, I always do. I think it’s important to know a function like  $f(x)=|x|$  is continuous everywhere but not differentiable at 0, so the inverse doesn’t hold.
- R : What about another counterexample illustrating the same point?
- A : ...well I could give  $f(x)=|x+2|$  or something like that
- R : This looks like the other, it seems the problem is always a sharp point, can you give a (continuous) function that the point with no derivative is not a sharp point ?
- A : ... mm, no, I haven’t ever thought about it.

His personal example space (Watson & Mason, 2005) seems to be structured around the basic examples given in the book and he demonstrates an accessibility and easiness to the use of such examples. How he chooses which kind of examples to present and when?

- A : In almost every paragraph where we have a definition or a theorem that I have spotted some misunderstanding, I have a stock of possible examples to correct them or to make the students pay attention to.
- R : Looking at the outline of some lessons you have written, I see you are embedding in different parts of the lesson examples...
- A : It depends primarily on the students of the class, for example in a lower than the average class I wouldn’t use all of the examples or I would use them later

On the other hand he is not exhibiting the same fluency in giving content meta-examples:

- R : Can you give me another example of a topic in calculus where you can make connection to some other non-mathematical area?
- A : ... introducing derivative or in integration I use the velocity - space example
- R : These are examples that the book also uses. Any other?
- A : ... No, I don’t use anything else..., nothing else crosses my mind.
- R : An example connecting a certain topic in calculus to some other mathematical area?
- A : ...I don’t give links like that, except maybe that of a complex number as a vector
- R : What is the reason that you don’t use examples establishing connections like these?
- A : Actually I haven’t thought about it, since the book doesn’t make any such connections,..., but yes I guess it looks like a good idea pedagogically.

Another interesting part was that in his taped session with a student he talked much about “the need not to trust only our intuition” but he wasn’t able to illustrate this with an example even during our interviews. Overall the picture of teacher-student A, taking into account all his (written and verbal) responses and his session with a student, is that of one with a above the average math background which seems to integrate a lot of examples in his usual teaching methods. At the same time, a considerable lack of fluency is apparent in either constructing examples that are different than the “standard” ones given by the book or in giving content meta-examples of certain applications of some of his teaching methods like making connections to other topics or underlining the difference between intuition and proof. The second teacher-student S, an experienced secondary education teacher with 16 years of teaching experience, answers to the mathematical parts of the questionnaires almost perfectly (29/30) demonstrating a deep command of the calculus concepts she is teaching. In her written answers she is using examples when in need to introduce or to make clear a concept to the students, as an integral part of her teaching practice. Most of the examples she is giving when asked in the interview are not trivial and often easily generalizable. For example in the question what kind of examples she could give, when explaining the property  $\lim_{x \rightarrow 2} (f(x) + g(x)) = \lim_{x \rightarrow 2} f(x) + \lim_{x \rightarrow 2} g(x)$  she came up with the following two counterexamples :  $f(x)=1-\chi_{\mathbb{Q}}$  ,  $g(x)=\chi_{\mathbb{Q}}$  ( $\chi_{\mathbb{Q}}$  is the characteristic function of rationals) and  $f(x)=(x^2-4)^{1/2}$  ,  $g(x)=(2-x)^{1/2}$  . In her audiotaped sessions with a student, she used specific examples to clarify some points that were problematic to her student. Not all of the examples she has given are of the same type as the book’s. In the introduction of the inverse of a function she is using a original problem regarding the cost of a taxi drive, which in her words : “introduces in a simple manner the need of the inverse, the way it functions and it’s relevant domain of definition”. Regarding her use of content meta-examples :

S : I think the student here mistakenly transfers the method from another situation to this case

R : How often is this mistake?

S : I guess a lot. They usually learn a method without paying attention to the underlying structure, so they act algorithmically just applying the same method whenever they see similar characteristics.

R : Can you give another example of this happening?

S : When they learn about solving inequalities they usually don’t consider the sign of the factor they multiply and they solve it exactly like an equation.

R : Any other example from calculus where they exhibit the same algorithmic attitude?

S : ...when they learn l’Hospital’s rule they usually take the derivatives of nominator and denominator without considering the existence or not of the limit of the initial quotient.

and then she goes on to describe the didacting methods she is using to cope with the previous problems. One of her methods is by generating uncertainty using competing



claims tasks (in the sense of Zaslavsky, 2005). Then she is asked if she can name another topic where she uses the same method and she easily responds by explaining the case of the indefinite integral which is defined as a set of functions. On the other hand, although she regards the building of bridges between mathematics and other disciplines as “of outmost importance” she is not capable of giving any example different by the classic ones that the book gives:

S : I could think of describing velocity and acceleration in terms of derivatives, or areas in terms of definite integrals..

R : Do you have any other like that ?

S : Actually no, I don't think so

R : ... even though you said it is very important to build connections like this...

S : Yes, I wish I had, but I guess I haven't think much about searching for them

She has the same difficulty finding any example of a paragraph that she deviates from the the order that the book has, although she sometimes is doing it :

S : ... sometimes I differentiate the way I teach a topic from the one suggested by the book depending on the class, for example last year my class had some trouble understanding limits, so I skiped the asymptotes paragraph and I did it in later in conjunction with the tangents lines in the derivatives.

## DISCUSSION

This paper is part of a larger study of the characteristics of three basic categories of teachers' knowledge: S.C.K, K.C.T and K.C.T, in the special case of secondary education teachers that teach calculus. There many key aspects that characterize each category and some of them acquire a different colour and weight under the different demands and peculiarities of secondary education. We also regard that in this context, specialized knowledge requires a mathematical way of thinking that is not that apparent in the case of teaching in primary or elementary school. One of the many aspects that can give insight into the knoweldge a teacher posseses is the notion of exemplification. We choose exemplification to portay on one hand the characteristic entanglement that exists between the different categories of teachers' knowledge and on the other hand the way that a single concept - method penetrates different layers of knowledge. The two teachers presented briefly above seem to handle quite satisfactory the examples as an integral part of their teaching practice. If we were to measure somehow their specialized content knoweldge by examining their behavior in exemplification (fluency and accuracy in giving mathematical examples, generality and useness of examples given, correspondence to students' need) we could characterize both of them as rather good. They appeared to be ready to explain certain topics in calculus by carefully choosen examples and they more or less seem to be aware of the pedagogical role of examples in teaching. At the same time, their knowledge of the part they would place each example in their teaching sequence revealed that they both had increased level of knowledge of content and teaching.

But still, this is not the whole story. By introducing the concept of content meta-examples the picture doesn't remain the same. What we see is a different aspect of their pedagogical profile which somehow has to be counted towards the overall picture. Both teachers have difficulty in demonstrating with content meta-examples where they use specific didactic methods like making links to other mathematical, physical or real life topics, or where they encounter general problematic motives like peculiar use of the language and different semantic understanding. They were very fluent in giving examples similar to the book's or to the instruction booklet's but they couldn't describe anything other than that. Does this mean they haven't felt the need to enrich the design of their teaching with similar cases or do they lack some kind of pedagogical knowledge? We think neither of them is true. Having more than 11 years of experience each and showing a better than average knowledge of pedagogy and calculus, probably the problem lies somewhere else. Is there a special knowledge (or meta-knowledge) needed when teaching calculus that permits to think "mathematically"? Are other parameters that intersect all of the three categories above, like the making and use of representations, the use of proofs etc that could probably be more effectively understood by allowing for the existence of such a mathematical way of thinking? Is there a different kind of knowledge (or way of thinking or habit-of-mind) that transcends the S.C.K and yet it is indispensable to the pedagogical knowledge?

The questions that remain or open anew are more than the answers we get. We still don't know the importance that a teacher's ability to think content meta-examples can play in his/her teaching practice. In the overall picture, there is more to be learned on the different meanings that the categories S.C.K, K.C.S and K.C.T may take when applied to teaching in secondary education. Finding the special characteristics that differentiate the knowledge and teaching of calculus from the teaching of math in primary or elementary school, will not only clarify the categories per se and give us a better theoretical lens. It will help us to design better teacher preparation programmes that could have a significant impact on our education quality.

Docendo discitur

## References

- An, S., Kulm, G., & Wu, Z. (2004). The pedagogical content knowledge of middle school, mathematics teachers in China and the U.S. *Journal of Mathematics Teacher Education*, 7, 145-172.
- Ball D. L., Thames M.H., & Phelps G. (2007). Content knowledge for teaching: what makes it special? Retrieved September 1, 2007, from [http://www.personal.umich.edu/~dball/papers/BallThamesPhelps\\_ContentKnowledgeforTeaching.pdf](http://www.personal.umich.edu/~dball/papers/BallThamesPhelps_ContentKnowledgeforTeaching.pdf)
- Ball, D. L. & Bass, H. (2003). Toward a practice-based theory of mathematical knowledge for teaching. In B. Davis & E. Simmt (Eds.), *Proceedings of the 2002 Annual Meeting of the Canadian Mathematics Education Study Group* (pp. 3-14). Edmonton, AB: CMESG/GDEDM.

- Ball, D. L., Hill, H. H., & Bass, H. (2005). Knowing mathematics for teaching: Who knows mathematics well enough to teach third grade, and how can we decide? *American Educator, Fall*, 14-46.
- Bills L., Dreyfus T., Mason J., Tsamir P., Watson A., & Zaslavsky O. (2006). Exemplification in Mathematics Education. In J. Novotna (Ed.), *Proceedings of the 30th Conference of the International Group for the Psychology of Mathematics Education*. (Vol. 1, pp. 126-154).Prague, Czech Republic: PME.
- de Berg, K. C. & Greive, C. (1999). Understanding the siphon: An example of the development of pedagogical content knowledge using textbooks and the writings of early scientists. *Australian Science Teachers' Journal*, 45(4), 19-26.
- Grossman, P. L., Wilson, S. M., & Shulman, L. S. (1989). Teachers of substance: Subject matter knowledge for teaching. In M. Reynolds (Ed.), *The Knowledge Base for Beginning Teachers* (pp. 23-36). New York: Pergamon.
- Niess, M. L. (2005). Preparing teachers to teach science and mathematics with technology: Developing a technology pedagogical content knowledge. *Teaching and Teacher Education*, 21, 509-523.
- Peled, I. & Zaslavsky, O. (1997). Counter-examples that (only) prove and counterexamples that (also) explain. *FOCUS on Learning Problems in mathematics*, 19(3), 49- 61.
- Renkl, A. (2002) Worked-out examples: Instructional explanations support learning by selfexplanations. *Learning and Instruction*, 12, 529-556.
- Shulman, L. S. (1986). Those who understand: Knowledge growth in teaching. *Educational Researcher*, 15(2), 4-14.
- Shulman, L. S. (1987). Knowledge and teaching: Foundations of the new reform. *Harvard Educational Review*, 57, 1-22.
- Sowder, L. (1980). Concept and principle learning. In R. Shumway (Ed.), *Research in Mathematics Education* (pp. 244-285). Reston, VA, USA: NCTM.
- Watson, A. & Mason, J. (2005). Mathematics as a constructive activity: Learners *generating examples*. Mahwah, NJ, USA: Erlbaum.
- Zazkis R. & Leikin R. (2007). Generating examples: from pedagogical tool to a research tool. *For the Learning of Mathematics* 27(2), 15-21.
- Zaslavsky, O. (2005). Seizing the opportunity to create uncertainty in learning mathematics. *Educational Studies in Mathematics*, 60, 297-321.

# **ABDUCTION - A TOOL FOR ANALYSING STUDENTS' IDEAS**

Michael Meyer

TU Dortmund

*Abduction as the third elementary inference has been elaborated by the American philosopher Charles S. Peirce, besides deduction and induction. Abductive reasoning is the process of forming "hypotheses" in order to explain facts. In this paper, abduction is first discussed from a theoretical point of view as a conceptual tool to describe structures of individual and social processes of generating ideas. Necessary and preferable conditions for learning by discovery are described. Using the pattern of abduction to analyse students' interactions while discovering mathematical knowledge, in the second part of this paper a student's comment will briefly be reconstructed.*

## **INTRODUCTION**

Since the raise of constructivist approaches (cf. Cobb et. al., 1992), mathematics education research has focused on individual and social processes of knowledge construction. In spite of the importance of those processes there is still a lack of theoretical approaches which help to reflect and analyse the processes of generating ideas. An exception is Steinbring's (2005) epistemological triangle, which enables the analysis of static moments in these processes. Contrarily there are some tools for analysing proofs and arguments like formal logic or the pattern of Toulmin (cf. Krummheuer 1995, Schwarzkopf 2000).

In this paper I want to present the concept of abduction as a tool which supports the understanding and enables the reconstruction of processes of knowledge construction. Besides deduction and induction the abduction has been elaborated by the American philosopher Charles Sanders Peirce as the third elementary inference. Lately there has been a growing interest in the relevance of abduction in mathematics education: First, researchers' interpretations of classroom interaction were justified with this theory (Voigt, 1984, pp. 83; Beck and Jungwirth, 1999). Second, abduction was quoted from a philosophical point of view as the necessary inference for the acquisition of knowledge (e.g., Hoffmann, 1999). Also there are first approaches to reconstruct abductions from students' comments using the pattern of Toulmin (Knipping, 2003; Pedemonte, 2003).

## **ABDUCTION, DEDUCTION AND INDUCTION**

In his later writings Peirce defines the three inferences abduction, induction and deduction as three different steps in the process of inquiry:

... there are but three elementary kinds of reasoning. The first, which I call abduction ... consists in examining a mass of facts and in allowing these facts to suggest a theory. In this way we gain new ideas; but there is no force in the reasoning. The second kind of

reasoning is deduction, or necessary reasoning. It is applicable only to an ideal state of things, or to a state of things in so far as it may conform to an ideal. It merely gives a new aspect to the premisses. ... The third way of reasoning is induction, or experimental research. Its procedure is this. Abduction having suggested a theory, we employ deduction to deduce from that ideal theory a promiscuous variety of consequences to the effect that if we perform certain acts, we shall find ourselves confronted with certain experiences. We then proceed to try these experiments, and if the predictions of the theory are verified, we have a proportionate confidence that the experiments that remain to be tried will confirm the theory. I say that these three are the only elementary modes of reasoning there are (CP 8.209).

Thus abduction appears as the inference from observed facts to new ideas. Induction appears as the inference from ideas to the empirical confirmation of these ideas. Thus Peirce's conceptualization differs from other concepts of induction as path from observed facts towards new rules. In the following course of this paper this distinction will shortly be confirmed by a closer look at the structural patterns of abduction and induction. Mainly I will discuss the benefits of Peirce's concept of abduction for the understanding of constructing new ideas. As deduction is the well-known 'typical' mathematical inference, it is not discussed in detail here.

### Induction

Figure 1 shows the pattern of induction. Induction has often been used to describe the generation of new rules. The underlying concept of this point of view can be described as follows: 'What can be observed a couple of times is always valid'. Let us consider an example: We see three white swans and conclude that every swan has to be white. But how do we get the idea that the attribute of the animal "being a swan" has something to do with the attribute "being of white colour"? In other words: Induction leaves an important question unanswered: How do we get the presumption that the case has something to do with the result, what leads us to connect this case and this result?

case:	$C(x_0)$
result:	$R(x_0)$
<hr/> rule:	$\forall i: C(x_i) \Rightarrow R(x_i)$

Figure 1. The pattern of induction.

This question is treated when we take a closer look on the process of discovering knowledge. If we do so, we would get a concept of the induction as "confirmation" (cf. Hoffmann, 1999, p. 272). However I prefer to take a look at the processes of generating new ideas. For a more detailed discussion of induction, please refer to Meyer (2007).

### Abduction

In the course of his philosophy Peirce offered several different descriptions and patterns of abduction. In his later writings he defines the "perfectly definitive logical form" (CP 5.189) of abduction as follows:

“The surprising fact, C, is observed;  
 But if A were true, C would be a matter of course,  
 Hence, there is reason to suspect that A is true.”

Figure 2. Peirce’s description of abduction (Peirce, CP 5.189, 1903).

Hempel und Oppenheim enforced conditions which every scientific explanation has to meet. First the explanation has to contain at least one general rule. (Also Peirce used a rule as a mediator between the observed fact C and the reason A in his former writings, cf. CP 2.622). Second the observation has to be logically inferable from the explanation (Stegmüller, 1976, p. 452).

result:	$R(x_0)$
rule:	$\forall i: C(x_i) \Rightarrow R(x_i)$
_____ case:	$C(x_0)$

Figure 3. The pattern of abduction.

Thus we get the pattern of abduction as shown in Figure 3. Starting with observing a surprising fact, we notice a possible explanation: A general rule leads to a case, which can explain the fact. If we are aware of the rule, the observed fact appears as a specific result of it. This is a necessary condition for the fact getting its ‘logical status’ as a result. The rule occurs tentatively. It could be that another rule (and accordingly another case) has to be used to explain the observed fact. Thus abduction is only a hypothetical inference and has nothing to do with “logical inference” in the sense of mathematical formal logic.

Let us consider an example: Sherlock Holmes notices flower soil left next to a dead body. One possible explanation for this given fact is: The gardener killed the person after work, because if a careless gardener kills a person after work, he would leave traces of the gardening at the scene. Thus we get the following abduction:

result:	Flower soil is left next to the dead body.
rule:	If a careless gardener murders a person after work, he leaves traces of the gardening at the scene.
_____ case:	The careless gardener could have murdered the person after his work.

Figure 4. The abduction of Sherlock Holmes.

As we know the gardener is not always the murderer. Also another person could have come through the flower bed. Thus we see concrete: An abduction only leads to a possible not necessary case.

If we take a closer look at the pattern of abduction we are confronted with a problem: The (abductive) way to generate new ideas does not start with two premises, because if the rule is present, we are also aware of the case (cf. CP 5.189). The rule is not a

premise. Therefore Frankfurt (1958, p. 597) calls Peirce's description of abduction „[...] a kind of argument by which we come to accept a certain proposition as an hypothesis, or recognize that it is an hypothesis". Thus we have to differentiate between abduction as a process of making our hypothesis public (Figure 3) and abduction considered as a cognitive process. The second one starts with only one given premise: The observed fact which occurs as a result of a general rule, if we are aware of this rule.

Following Eco it is unimportant if we first get the rule or the case. The proper problem is "... how to figure out both the Rule and the Case *at the same time*, since they are inversely related, tied together by a sort of chiasmus ...” (Eco, 1983, p. 203). The cognitive process of finding an explanatory case is not logical in nature:

„The abductive suggestion comes to us like a flash. It is an act of *insight*, although of extremely fallible insight. It is true that the different elements of the hypothesis were in our minds before; but it is the idea of putting together what we had never before dreamed of putting together which flashes the new suggestion before our contemplation.“ (Peirce, CP 5.181)

We see ourselves confronted only with a surprising fact before we carry out our abduction. We take the fact for granted, completely irrespective of what we think about it. We feel compelled to allege the fact. It is the fact per se but for us the fact is only present against the background of our own cognitive abilities. Thus the generation of an (useful) idea requires insight in that specific field of knowledge. “[T]here is no *creatio ex nihilo* in abduction [...]“ (Hoffmann, 1999, p. 288). We are putting old ideas together and create something new, which is - given by the observed fact - supported by reality.

Altogether, abduction contains both: perceptive as well as rational elements. Thus, for empirical studies, we meet the methodological difficulties that a reconstruction of discoveries, which are made public in the mathematical classroom, cannot implicate the individual cognitive process of generating new ideas.

## **RECONSTRUCTING ONE EXAMPLE FOR THE GENERATION OF IDEAS**

### **Methodology**

The empirical data emerged from classroom experiments in the 10<sup>th</sup>, 7<sup>th</sup> and 4<sup>th</sup> grade (in Germany). Altogether 7 classes had been visited for 4-5 lessons (see Meyer 2007). The study aimed at the reconstruction of processes of generating ideas and argumentations by using the concept of abduction, deduction, induction and the pattern of Toulmin.

For giving them the opportunities to construct new ideas, the students were exposed to tasks they could not solve with their former knowledge. They had to construct new ideas and different ways of proving these ideas. The students' comments were video- and audiotaped.

Abduction is the necessary inference for constructing ideas, for students as well as for empirical researchers. Thus we have to refer to the above drawn distinction (between

abduction as a cognitive process and abduction as a public process of making our ideas clear). That is why the study only focuses on reconstructing the *rational elements* of an abduction, whereas the cognitive ‘flash of genius’ cannot be captured methodologically within the chosen theoretical framework.

The qualitative interpretation of data is founded on an ethnomethodological and interactionist point of view (cf. Voigt 1984, Meyer 2007). By analysing the mathematical coherence between and within students’ comments, we are able to reconstruct the social learning in the mathematical classroom using the pattern of abduction. Conducted as an explorative study, the theoretical concepts had been tightened in the course of data analysis.

### The example

The little example presented here was situated in a 7<sup>th</sup> grade (German students aged from 12 to 13 years). In the former lessons the students got to know proportional and inversely proportional relations.

Now the teacher (T) presents the graph of a linear function and asks the students to complete the expression  $x \mapsto \cdot x$  with a suitable factor (cf. Figure 5).

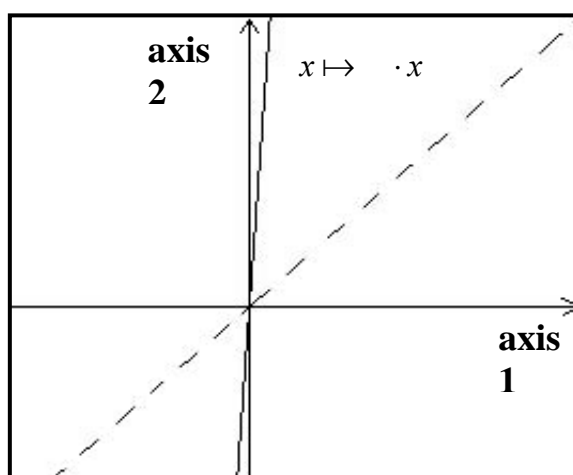

Figure 5. Translated excerpt from the blackboard figure in the beginning of the scene.

Die Aufgabe versteh ich nicht, gehts hier um eine Parabel?

The students’ comments first concern the bisector of the both axes, which is going to be described as  $x \mapsto 1 \cdot x$ . Now we will take a closer look at the following course of this scene:

- 1 Teacher: Why is the broken line the bisector - the graph for  $x \mapsto 1 \cdot x$ ? Oliver?
- 2 Oliver: Maybe because it is 45°?
- 3 Teacher: Yes, it is 45° - between the first axis and the broken line (*points at the angle*). Stefan.
- 4 Stefan: Shouldn’t that, shouldn’t that then be less than 2? Because the double



amount would have to be 2. That is just exactly the 90<sup>th</sup> (was ist die 90ste?). Therefore that must be less than 2, about 1.9 or so.

**Analysing students' comments.** What idea Stefan adds to the classroom interaction? Is it reconstructable by the concept of abduction and what can we learn by analysing the student's comment in this way?

Stefan suggests that the doubling of the angle between the graph and the 'axis 1' would bring the doubling of the coefficient with it. Thus he gets the idea of a proportional coherence between the angle and the coefficient:

result:	The angle between the graph and the axis of $x \mapsto \cdot x$ is nearly double that of $x \mapsto 1 \cdot x$ .
rule:	If the coefficient in $x \mapsto a \cdot x$ is going to be doubled, the angle between the graph and the first axis would double too.
case:	The coefficient in $x \mapsto \cdot x$ is approximately $2 \cdot 1 = 2$ .

Figure 6. Stefan's abduction.

The starting point of his abduction is a combination of the blackboard figure and the comment of Oliver. Oliver directed the attention towards the angle between the graphs and the 'axis 1'. He made the value of the angle responsible for the bisector being the graph for  $x \mapsto 1 \cdot x$ . In the classroom interaction Stefan uses this comment to announce a possible reason. Independent of Stefan's individual cognitive processes this can be interpreted to be a process of social learning in this classroom interaction. Nevertheless other interpretations are possible (examples given in Meyer 2007, pp. 218), since the abduction of the researcher is only a hypothetical inference.

The students did (hopefully) not know the rule of this abduction before. Thus the example indicates how students establish new rules in the classroom communication. Eco (1983, pp. 206) calls this type of abduction "creative" and differentiates it from "undercoded" and "overcoded" abductions. The later ones consist in associating known rules to explain the observed facts. Thus up to three ideas can emerge from every abduction: 1. the new case (every abduction), 2. the coherence between the rule and the observed fact (every abduction) and 3. the new rule (creative abduction). Therefore it is not enough to prove only the case of an abduction. Also the rule can be proven.

Stefan himself does not explicate the rule of his creative abduction. This phenomenon could be observed within a lot of scenes - concerning the reconstruction of abductions as well as the reconstruction of inductions and deductions. This gap has to be closed by the listener (cf. the "et-cetera-rule" described by Cicourel, 1981, pp. 177). The listeners (the students and the teacher) have to read between the lines. This implies that the teacher should not only refute the abductively inferred case. Also he can refute the generated rule in order to avoid that the students would notice a general

rule with only some exceptions (e.g., Stefan will use the rule of his abduction every time, if only the angle is not close to 90 degree).

The example shows that the semantic fields of an abduction can be close together - even within a creative abduction. The empirical data revealed that the different types of abductions can not be used to describe the quality of the cognitive performances while constructing new ideas. Overcoded abductions (where the association of the known rule is given automatically) also can be in need of great efforts, if the concrete case of the abduction is not obvious. Thus we have to differentiate between 'superficial' and 'thorough' abductions. The knowledge emerging from a superficial abduction remains at the surface of what is perceptible.

## FINAL REMARKS

By using abduction as a tool for a better understanding and for the reconstruction of the generation of ideas in the mathematical classroom, the social processes of knowledge construction became analysable. Nevertheless the consideration of the abduction can not capture the individual cognitive processes of constructing new knowledge, but it provides insight into those processes. Discovering ideas is not a 'creatio ex nihilo'. The students have to be confronted with (surprising) facts which can be identified as results of (new) general rules. It is not sufficient to present them any mathematical context and to wait till the 'flash of genius' will fortunately hit someone.

The empirical work showed that the semantic fields between the observed fact (which appears as a result of the rule afterwards) and the case have to be relatively close together, if the students are supposed to invent new rules. If the abductively inferred knowledge should be of deeper matter, the students are in need of a) a sufficient background knowledge and/or b) the guidance of the teacher. Also the important role of the teacher could be noticed several times: Students often tend to trust the plausibility of their abduction, sometimes more than counter evidences. They often do not see the need for a proof. Even though we are getting up to three new ideas from every single abduction.

## References

- Beck, C. & Jungwirth, H. (1999). Deutungshypothesen in der interpretativen Forschung. *Journal für Mathematikdidaktik*, 20(4), 231-259.
- CP, Peirce, Ch. S. *Collected Papers of Charles Sanders Peirce* (Volumes I-VI, ed. by C. Hartshorne, and P. Weiss, 1931-1935; Volumes VII-VIII, ed. by A. W. Burks, 1958; quotations according to volume and paragraph). Cambridge, MA: Harvard University Press.
- Cicourel, A.V. (1981). Basisregeln und normative Regeln im Prozess des Aushandelns von Status und Rolle. In A. B. Soziologen (Eds.): *Alltagswissen, Interaktion und gesellschaftliche Wirklichkeit* (Volume 1, pp. 147-188). Reinbeck: Rowohlt.
- Cobb, P., Yackel, E., & Wood, T. (1992). A constructivist alternative to the representational view of mind in mathematics education, *Journal for Research in Mathematics Education* 23(1), 2-33.

- Eco, U. (1983). Horns, Hooves, Insteps: Some Hypotheses on three types of abduction. In U. Eco & T. A. Sebeok (Eds.), *The Sign of the Three. Dupin, Holmes, Peirce* (pp. 198-220). Bloomington: Indiana University Press.
- Frankfurt, H.G. (1958). Peirce's notion of abduction. *Journal of Philosophy*, 55, 593-597.
- Hoffmann, M. (1999). Problems with Peirce's concept of abduction. *Foundations of Science*, 4(3), 271-305.
- Knipping, Ch. (2003). Argumentation structures in classroom proving situations. In: Mariotti, M.A. (Ed.), *Proceedings of the Third Congress of the European Society for Research in Mathematics Education*. Bellaria, Italy: CERME (Online: [http://fibonacci.dm.unipi.it/~didattica/CERME3/proceedings/Groups/TG4/TG4\\_Knipping\\_cerme3.pdf](http://fibonacci.dm.unipi.it/~didattica/CERME3/proceedings/Groups/TG4/TG4_Knipping_cerme3.pdf)).
- Krummheuer, G. (1995). The ethnography of argumentation. In Cobb, P. & H. Bauersfeld (Eds.), *The Emergence of Mathematical Meaning: Interaction in Classroom Cultures* (pp. 229-270). Hillsdale: Erlbaum.
- Meyer, M. (2007). *Entdecken und Begründen im Mathematikunterricht. Von der Abduktion zum Argument* [English: Discovering and reasoning in the mathematical classroom. From abduction to argument]. Hildesheim: Franzbecker.
- Pedemonte, B. (2003). What kind of proof can be constructed following an abductive argumentation? In Mariotti, M.A. (Ed.), *Proceedings of the Third Congress of the European Society for Research in Mathematics Education*. Bellaria, Italy: CERME (Online: [http://fibonacci.dm.unipi.it/~didattica/CERME3/proceedings/Groups/TG4/TG4\\_Pedemonte\\_cerme3.pdf](http://fibonacci.dm.unipi.it/~didattica/CERME3/proceedings/Groups/TG4/TG4_Pedemonte_cerme3.pdf)).
- Schwarzkopf, R. (2000). *Argumentationsprozesse im Mathematikunterricht. Theoretische Grundlagen und Fallstudien*. Hildesheim: Franzbecker.
- Stegmüller, W. (1976). *Hauptströmungen der Gegenwartsphilosophie* (Vol. 1). Stuttgart: Körner.
- Steinbring, H. (2005). *The Construction of New Mathematical Knowledge in Classroom Interaction: An Epistemological Perspective*. Berlin: Springer.
- Voigt, J. (1984). *Interaktionsmuster und Routinen im Mathematikunterricht. Theoretische Grundlagen und mikroethnographische Falluntersuchungen*. Weinheim: Beltz.

# ASSESSING AND DEVELOPING PEDAGOGICAL CONTENT KNOWLEDGE: A NEW APPROACH

Christina Misailidou

University of Stirling

*This paper reports an innovative methodology for assessing and possibly developing the mathematics teachers' 'pedagogical content knowledge' (PCK). The study reported here builds on previous work that involved the development of a diagnostic test for the topic of 'ratio and proportion'. A modified version of this test was given as a questionnaire to a sample of mathematics teachers with the aim to assess their PCK. The adoption of the Rasch model for the analysis of the data provided feedback tools such as 'Item maps' and 'Performance maps'. These tools together with the diagnostic instrument are proposed as a new and more efficient approach for exploring the necessary knowledge for teaching.*

## INTRODUCTION AND BACKGROUND

Learning to teach mathematics effectively can be a challenge: it requires not only a sound knowledge of the subject per se but more importantly the development of what Shulman (1986) calls 'pedagogical content knowledge' ('PCK'). 'Subject matter content knowledge' refers to 'the amount and organization of knowledge per se in the mind of the teacher' (Shulman 1986, p.9) whereas 'pedagogical content knowledge' refers to 'subject matter knowledge for teaching [which includes] an understanding of ...the conceptions and preconceptions that students...bring with them to the learning of those most frequently taught topics and lessons. If those preconceptions are misconceptions...teachers need knowledge of the strategies most likely to be fruitful in reorganizing the understanding of learners' (Shulman 1986, p.9-10).

Hence teachers need to (a) be aware of their students' misconceptions (b) use teaching strategies that will help their students reorganize their thinking. Nevertheless, several research studies suggest that pre-service and even experienced teachers are not adequately aware of their students' thinking (Tirosh, 2000; Hadjidemetriou & Williams, 2001). In addition, Pratt & Woods (2007) stress that teaching mathematics in a way that affects deeply the students' thinking is a great challenge even for experienced practitioners.

This paper focuses on 'ratio and proportion', a significant topic in school mathematics but also quite problematic to teach. Numerous studies documented that this is a difficult topic not only for school students (Hart, 1984; Misailidou, 2005) but also for adults and in fact for elementary school teachers as well (Ben-Chaim, Ilany, & Keret, 2002). Nevertheless, there is a gap in the related literature: there are not any research studies proposing a methodology for identifying, assessing and then developing the PCK that teachers need in order to teach this topic effectively. This report is an initial attempt to address this issue.

This study draws on the approach of Bell, Swan, Onslow, Pratt, & Purdy (1985) who suggest that ‘conceptual diagnostic tests’ can help teachers become aware of their pupils’ strategies. Additionally, the research literature on children’s thinking, strategies and errors in problem solving contexts is viewed as a resource for developing effective assessment tools. Teachers can use these tools to promote effective formative assessment, i.e. assessment for learning. Such a diagnostic instrument (for the topic of ratio and proportion) was developed during previous work with the aid of Rasch methodology (Rasch, 1980). Key results from that effort were reported in previous PME conferences (e.g. Misailidou and Williams, 2003b).

This study attempts to demonstrate that such diagnostic tests can be suitably modified and become new instruments with dual purpose: to assess the teachers’ PCK and then aid the teachers in enhancing such a knowledge.

### **METHODOLOGY AND DATA ANALYSIS**

A previous research project involved the development of a diagnostic test for detecting the pupils’ errors and misconceptions concerning the topic of ‘ratio and proportion’. Items for this instrument were either adopted with slight modifications from previous research studies or have been created based on findings of that research. The criterion for their selection was always their diagnostic potential, i.e. their potential to provoke a variety of responses from the pupils, including errors stemming from the well-documented in the relevant literature, additive strategy. The instrument was given to a sample of 303 pupils aged 10 to 14 years in England. The results were subjected to a Rasch analysis in the usual way using Quest software. The analysis resulted in scaling the most common errors for each item with its difficulty (for more details see Misailidou & Williams, 2003). Small group discussions on selected items from the instrument followed the assessment part of the study and involved 63 pupils from the sample above. The discourse analysis of the dialogues offered ideas about tools and models that aided pupils to reorganise their thinking and overcome their errors (Misailidou and Williams, 2004).

The research reported here built upon the results mentioned above. It involved giving a modified version of the diagnostic test as questionnaire to a sample of teachers with instructions not only to answer each item but also

- to suggest errors that pupils are likely to make when attempting the particular item
- to suggest ideas/methods/tools that are likely to help the pupils overcome their difficulties
- to predict the difficulty of the item (on a five-point scale with the categories Very Easy, Easy, Moderate, Hard, Very Hard)

The study sample consisted of 48 secondary school mathematics teachers both in-service and pre-service. The study was conducted in two phases in England and in Scotland. The data were used to determine the PCK of this group of teachers. In accordance with Shulman (1986), the analysis focused on the questions: Are the

teachers aware of their pupils' conceptions and difficulties? Are they aware of strategies that could help their pupils overcome their difficulties? It was decided to explore how a Rasch analysis of the data could provide answers to the above questions. It has to be stressed here, that the aim of this study is to propose a new methodology rather than focusing on the actual results of this rather small sample.

## RESULTS

To illustrate the essence of the data (and due to lack of space) results from only one item from the diagnostic instrument are presented in this paper. The item is called 'Campers' and the data from the pupils' sample showed that it produced a high frequency of the erroneous strategy called 'constant difference' or 'additive strategy' (Misailidou & Williams, 2003). This is the most commonly reported erroneous strategy in the research literature related to proportional reasoning (e.g. Hart, 1984). The data from the group discussions indicated that the pupils could overcome their difficulties concerning this item with the help of appropriately orchestrated dialogue between them and the use of a pictorial model (Misailidou & Williams, 2004b). The teachers' data were subjected to a Rasch analysis in the usual way using Quest. The results were validated by subsequent individual interviews with the teachers.

An informative output of the statistical analysis was the Quest 'Item map for all cases', which is presented (only for the 'Campers' item and therefore is called here 'The 'Campers' map') in Table 1. The numbers on the left represent the 'logit' scale which is essentially the difficulty scale for the items. In the middle, one can see the distribution of the items in reference to their difficulty estimates: the easiest item (Question 1) is the one at the bottom of the output (negative logits) whereas the hardest item is the one at the top (positive logits). Finally, on the left, one can see what percent of the sample answered each question correctly.

As expected, the easiest question for the teachers was to provide the answer to the problem (54% percent of the sample answered this correctly). It was quite surprising though the fact that 46% of a sample of mathematics teachers could not answer this problem! During the individual interviews that followed, several teachers claimed that they focused on the other questions and forgot to answer the first one. On the other hand, the most difficult question for the sample was the one that asked them: 'Could you suggest a tool/method/activity etc that could help the pupils overcome the above difficulties?' It was stressed to the teachers that they needed to explain the activity and not just write, for example, 'use a model' as an answer. As 'correct' were coded those answers that were suggesting and explaining clearly a method, activity etc. During the subsequent interviews, the teachers admitted that it was very difficult for them to think of appropriate teaching ideas for the 'Campers' item and in fact some claimed that they were thinking about the question even after the completion of the test.

Only 33% of the sample answered that the most frequent error for this item was likely to be the result of the additive strategy and only 29% of the sample predicted correctly how difficult this item is likely to be for their pupils ('Hard').

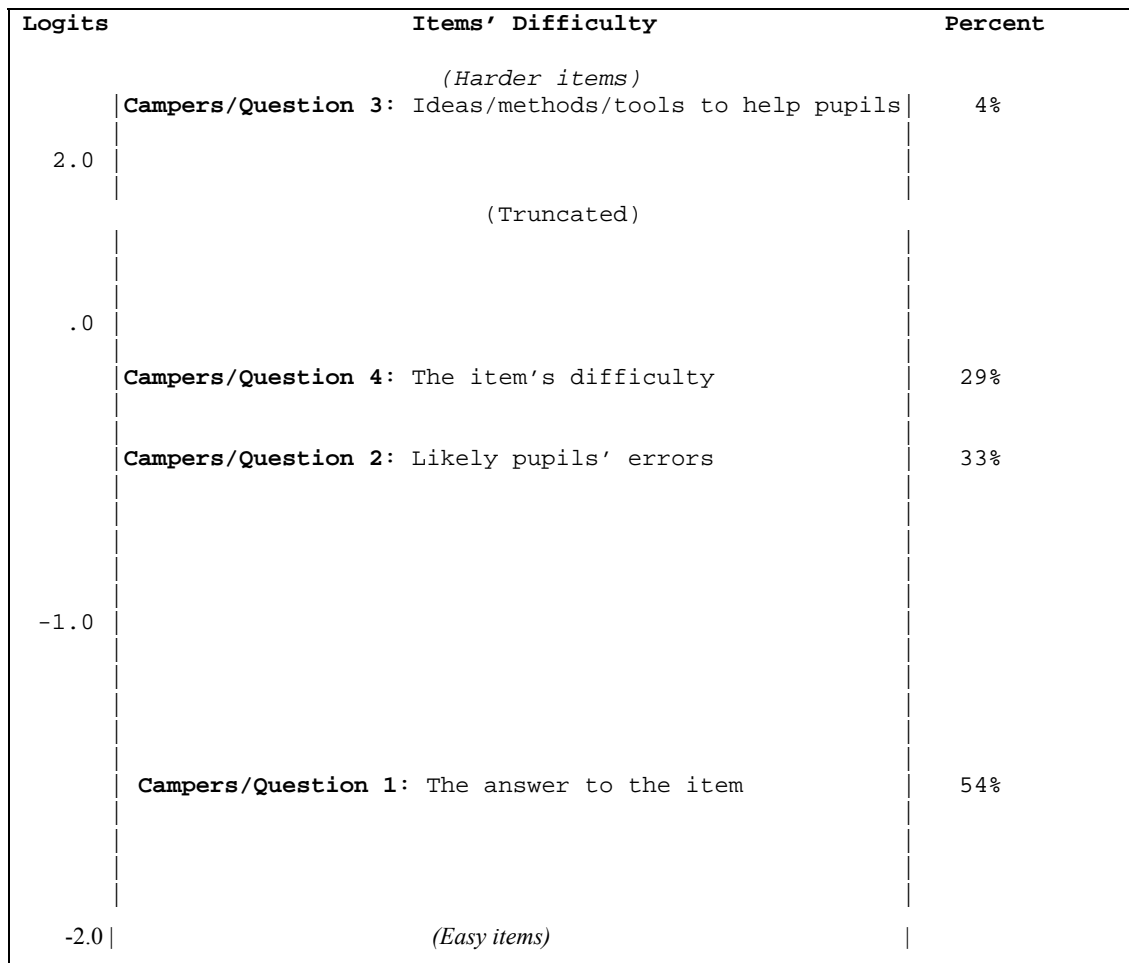

Table 1. The ‘Campers’ map

A Quest output that presents more clearly the item difficulty estimates is the ‘Table of item estimates’, part of which is presented in Table 2. For each one of the four questions its THRSH (item difficulty estimate) is given separately for pre-service and in-service teachers. Again, it is obvious that Question 3 was the most difficult for both of these subgroups and in fact (as expected) it was more difficult for the pre-service rather than the in-service teachers. It was unexpected though, to discover that for this particular sample Questions 2 and 4 appear to be more difficult for the in-service rather than the pre-service teachers. Due to the small size of the sample these results are considered provisional and subject to further confirmation from larger samples but they do indicate that even experienced teachers might need to develop their PCK in certain topics.

ITEM NAME	Pre-service Teachers		In-service teachers	
	THRSH		THRSH	
Campers/Question 1	-1.32		-1.59	
Campers/Question 2	-.37		0	
Campers/Question 3	1.69		1.59	
Campers/Question 4	-.01		0	

Table 2. Extract from the table of item estimates

Both Tables 1 and 2 display, in a concise way, information about the teachers' PCK concerning a specific area (the 'Campers' type of proportion related problems) of a specific topic (ratio and proportion). Such specialized information is considered valuable: Rissland-Michener (1978) stress that the efficient use of specific examples is an important characteristic of expert teaching knowledge. Additionally, 'problem solving' as a teaching strategy is increasingly becoming an important element of the mathematics curriculum and thus PCK related to particular problems is considered significant.

The 'Campers' map (complemented by the table of item estimates) provokes useful comparisons between different aspects of the teachers' PCK. It is obvious, for example, that Question 3 was far more difficult for the sample than the rest of the questions. This information could be valuable for teacher educators and education researchers as it points out the need for providing more teaching experiences for the topic of ratio, even for experienced teachers (for example, through 'communities of inquiry' as Jaworski (2003) suggests). It is also worth noticing that most of the teachers of the sample did not mention/did not think of the 'additive strategy' and inevitably could not predict how difficult this item could be for their pupils (Questions 2 and 4 have quite close difficulties). As this erroneous strategy has been documented by so many research studies, such results pose the crucial question of how research knowledge on this topic can be more effectively communicated to practitioners.

Finally, Quest produces an output called 'Kidmap' which illustrates the response patterns of each individual. The kidmap (which here is called 'Performance map') for the participant '18' (who was an in-service teacher) is presented in Figure 1.

At the top of the figure, there is the name of the candidate and her/his 'ability' estimate (in logits). In this context, 'ability' is the performance of the individual in this particular questionnaire. The items (Questions) are plotted according to their difficulty on a vertical logit scale and are situated on the left or the right side of the map according to whether the participant answered them correctly or not. The row of the three Xs denotes the participant's ability estimate. According to the Rasch model, the participant has a 50% chance to answer correctly the question which has the same difficulty as her/his ability estimate. This probability increases for questions below her/his ability estimate and decreases for questions above.

The performance map for this particular teacher informs that s/he answered correctly the Questions 1 and 2 and s/he was expected to do so given her/his estimated ability. S/he did not answer correctly the Question 4 but she was expected (according to the Rasch model) to answer it as it is located below her/his ability estimate. Finally, s/he did not answer Question 3 correctly but she was expected to do so, as this question is located above her ability estimate.

This study hypothesizes that the 'performance map' complements the assessment of the PCK but most importantly could be used as a tool that could aid each practitioner in



developing such a knowledge further. Ryan and Williams (2007) used a similar kind of output in interviews with pre-service teachers and report that it was very successful in provoking teacher reflection and as consequence in influencing their conceptions about their own PCK. It is suggested that the ‘Performance map’ (accompanied with simple directions on how to ‘read’ it) could aid teachers in identifying areas of weakness in their PCK and then working towards filling their knowledge gaps.

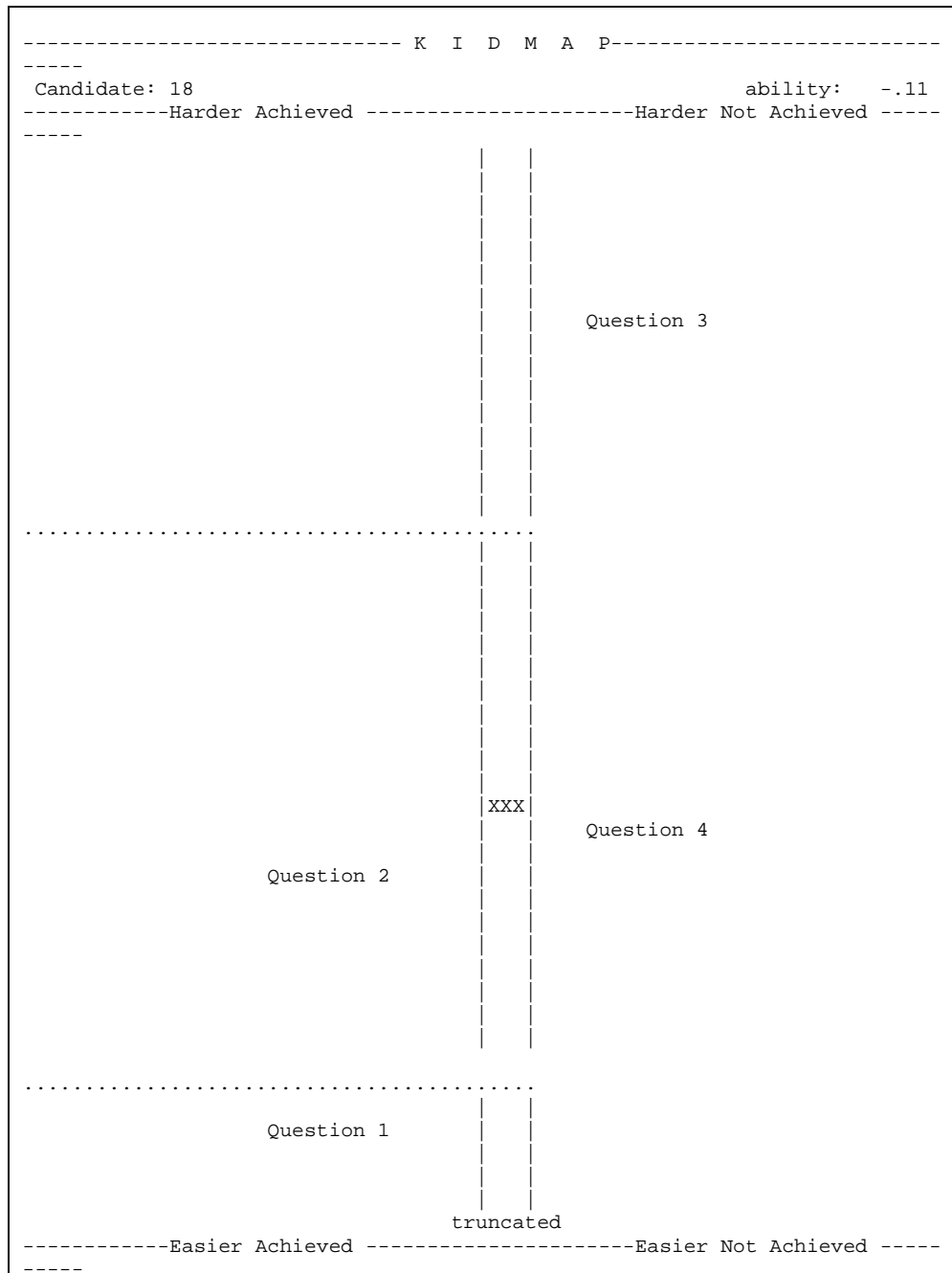

Figure 1. Performance map for an in-service teacher.

Similar outputs as the ones presented for the ‘Campers’ item were generated for all the items of the diagnostic test resulting in a large resource of feedback tools .

## CONCLUSION

Due to the relatively small sample of teachers, the focus of this paper is not the actual teachers' data. Instead, its aim is to fill the gap in the related literature by suggesting a new methodology for the evaluation and development of teachers' pedagogical content knowledge. A diagnostic test designed with the intention to reveal the pupils' thinking in the area of 'ratio and proportion' was calibrated using a large sample of secondary pupils. The results from this sample motivated the development of an instrument that investigates the teachers' knowledge about their learners. The Rasch analysis of the teachers' data provided tools such as 'Item maps' for each item of the instrument and 'Performance maps' for each teacher of the sample. The final 'product' of the analysis is a very rich resource that can be used by education researchers, teacher educators and practitioners for assessing and developing many different aspects of the PCK related to the topic of 'ratio and proportion'.

Li & Smith (2007) report a gap between prospective teachers' confidence in their own PCK and their actual knowledge which was found to be limited. This is not surprising as the PCK needed for teaching mathematics can be specific to a particular topic and even a particular task. Therefore, it is not realistic to expect pre-service teachers (and even in-service ones) to be able to easily identify and then acquire such a knowledge on their own. Tools such as the ones proposed by this study might be able to help the teachers towards this direction.

## References

- Bell, A., Swan, M., Onslow, B., Pratt, K., & Purdy, D. (1985). *Diagnostic Teaching: Teaching for Lifelong Learning*. Nottingham: Shell Centre for Mathematics Education.
- Ben-Chaim, D., Ilany, B., & Keret, Y. (2002). Mathematical and Pedagogical Knowledge of Pre- and In-Service Elementary Teachers before and After Experience in Proportional Reasoning Activities. *Proceedings of the 26th Conference of the International Group for the Psychology of Mathematics Education (PME26)*, 2, 81-88.
- Hadjidemetriou, C. & Williams, J. (2001). Children's graphical conceptions: assessment of learning for teaching. *Proceedings of the 25th Conference of the International Group for the Psychology of Mathematics Education (PME25)*, 3, 89-96.
- Jaworski, B. (2003). Research practice into/influencing mathematics teaching and learning development: Towards a theoretical framework based on co-learning partnerships. *Educational Studies of Mathematics*, 54(2-3), 249-282.
- Pratt, N. & Woods, P. (2007). Changing PGCE students' mathematical understanding through a community of inquiry into problem solving. *Research in Mathematics Education*, 9, 79-94.
- Li, Y. & Smith, D. (2007) Prospective middle school teachers' knowledge in mathematics and pedagogy for teaching - the case of fraction division. *Proceedings of the 31st Conference of the International Group for the Psychology of Mathematics Education (PME31)*, 3, 185-192.
- Misailidou, C. (2005). *The Assessment and Development of Children's Proportional Reasoning*. PhD thesis. School of Education. The University of Manchester.

- Misailidou, C. & Williams, J. (2003a). Diagnostic assessment of children's proportional reasoning. *Journal of Mathematical Behavior*, 22, 335-368.
- Misailidou, C. & Williams, J. (2003b). Measuring children's proportional reasoning, the tendency for an additive strategy and the effect of models. *Proceedings of the 27th Conference of the International Group for the Psychology of Mathematics Education (PME27)*, 3, 293-300.
- Misailidou, C. & Williams, J. (2004). Helping children to model proportionally in group argumentation: Overcoming the constant sum error. *Proceedings of the 28th Conference of the International Group for the Psychology of Mathematics Education (PME28)*, 3, 321-328.
- Misailidou, C. & Williams, J. (2004b). Improving performance on 'ratio' tasks: Can pupils convert their 'additive approach'? *Proceedings of the 10th International Congress on Mathematical Education (ICME 10)*.
- Rasch, G. (1980). *Probabilistic Models for Some Intelligence and Attainment Tests*. Chicago: The University of Chicago Press.
- Rissland-Michener, E. (1978). Understanding understanding mathematics. *Cognitive Science*, 2, 361-383.
- Ryan, J. & Williams, J. (2007). Mathsmaps for diagnostic assessment with pre-service teachers: Stories of mathematical knowledge. *Research in Mathematics Education*, 9, 95-109.
- Shulman, L. (1986). Those who understand: Knowledge growth in teaching. *Educational Researcher*, 15(2), 4-14.
- Tirosh, D. (2000). Enhancing prospective teachers' knowledge of children's conceptions: Division of fractions. *Journal for Research in Mathematics Education*, 31(1), 5-25.

# THIRD GRADERS' STRATEGIES AND USE OF RELATIONAL THINKING WHEN SOLVING NUMBER SENTENCES

Marta Molina, Encarnación Castro, and Enrique Castro

University of Granada

*Relational thinking is an important element of algebraic thinking which has potential for promoting the integration of arithmetic and algebra in the elementary curriculum and the development of a meaningful learning of arithmetic. Focusing on the context of number sentences, we have analysed the use of relational thinking by a group of third graders. In this paper we describe the various strategies identified in the students' production. The results evidence a great variability in the way of using relational thinking and a variable role of computation in that use.*

## **BACKGROUND: EARLY ALGEBRA AND RELATIONAL THINKING**

In the last two decades numerous researchers have analysed and promoted the integration of algebra in the elementary curriculum. This curricular proposal raises the introduction of algebraic ways of thinking in school mathematics from the first school years, aiming to foment mathematics learning with understanding and, more specifically, to ease the learning of algebra. Algebraic ways of thinking can naturally emerge from elementary mathematics and favour the students' conceptual development of deeper and more complex mathematics, from very early ages (Blanton & Kaput, 2005). In addition, the late introduction of this type of thinking in the school curriculum is thought to be responsible, at least in part, for pupils' subsequent difficulties (Bastable & Schifter, 2007; Carraher & Schliemann, 2007).

From this view, algebra is conceptualized quite broadly, including: the study and generalization of patterns and numeric relations, the study of structures abstracted from computation and relations, the study of functional relations, the development and manipulation of symbolism, and modelling (Kaput, 1998).

Interested in analysing the transition between arithmetic and algebra as well as promoting the integration of both sub-areas, various researchers (Carpenter, Franke, & Levi, 2003; Koehler, 2004; Molina, Castro, & Ambrose, 2006; Stephens, 2007) have focused their attention on the use of relational thinking. When working with arithmetic and algebraic expressions, relational thinking imply to consider expressions as a whole, analysing them to find their inner structure, and exploiting these relations to construct a solution strategy. It is equivalent to what Henjny, Jirotkova, & Kratochvilova (2006) call "conceptual meta-strategies".

Relational thinking has been mainly considered in the context of number sentences, where it has also been referred as analysing expressions (Molina & Ambrose, 2008). In this context, its use avoids computing the numeric value of each side of the sentence. For example, when considering the number sentence  $5 + 11 = 6 + \square$  some

students may notice that both expressions include addition and that one of the addends on the left side, 5, is one less than the addend on the other side, 6. Noticing this relation and having an (implicit or explicit) understanding of addition properties, enable students to solve this problem without having to perform the computations 5 plus 11 and 16 minus 6.

Similarly when solving equations such as  $\frac{1}{4} - \frac{x}{x-1} - x = 5 + \left(\frac{1}{4} - \frac{x}{x-1}\right)$ , instead of operating on the variables and the numbers and regrouping them, students may pay attention to the structure and appreciate that this equation is equivalent to  $-x = 5$  as the expression  $\frac{1}{4} - \frac{x}{x-1}$  is repeated in both sides (Hoch and Dreyfus, 2004).

This type of thinking implies the use of number sense and operation sense (as defined by Slavit, 1999) as well as structure sense (Linchevski & Livneh 1999; Hoch & Dreyfus, 2004). It promotes a structural learning of arithmetic by leading the attention to the structure of the expressions; in this way it contributes to the development of a good base for the formal study of algebra.

Previous studies (Carpenter et al., 2003; Koehler, 2004; Molina & Ambrose, 2008) have provided evidence that elementary students are capable of using this type of thinking when solving number sentences, overcoming some issues such as the “lack of closure” and an operational understanding of the equal sign. Even when it is not addressed in teaching, students follow a linear progression in the use of relational thinking as result of their arithmetic experience (Knuth, Alibali, McNeil, Weinberg, & Stephens, 2005; Stephens, 2007). The extent of the acquisition of this type of thinking is varied and there are students who seem unable to use it.

Although students predominantly tend to use computational strategies, some naturally and spontaneously use relational thinking, and when teaching is designed so that this use is promoted, many students apply this type of thinking for solving some number sentences (Molina & Ambrose, 2008).

Considering these evidences, some unexplored questions which are open to research are: when and how do students’ evidence use of relational thinking, what conditions this use, which differences are there between different students’ use, how students’ develop and progress in their use. Our aim in this paper is to provide partial responses to some of these questions by describing the different ways in which a group of third grade students applied relational thinking along a teaching experiment.

## **DESIGN OF THE STUDY**

Our research method shared the features of design experiments identified by Cobb and his colleagues (Cobb, Confrey, diSessa, Lehrer, & Schauble, 2003) (See Molina, Castro, & Castro, 2007, for further details). We have developed a teaching experiment in which we worked with a group of 26 eight-year old Spanish students during six sessions over a period of one year. In this paper we will mainly focus on the data gathered on the last four sessions as the first two were directed to exploring

and extending students' understanding of the equal sign. The general aim of this research work was to study students' thinking involved in solving number sentences, in the context of whole class activities and discussions. We analysed the strategies that students used to solve the sentences, focusing on detecting evidences of use of relational thinking.

The tasks used were number sentences, mostly true/false number sentences (e.g.  $72 = 56 - 14$ ,  $7 + 7 + 9 = 14 + 9$ ,  $10 + 4 = 4 + 10$ ) which were proposed to the students in written activities, in whole-class discussions and in interviews. All the sentences used were based on some arithmetic property or principle (e.g., commutative property, inverse relation of addition and subtraction, compensation relation) and, therefore, could be solved by using relational thinking.

We did not promote the learning of specific relational strategies but the development of a habit of looking for relations, trying to help students to make explicit and apply the knowledge of structural properties which they had from their previous arithmetic experience. Students' use of relational thinking was favoured by encouraging them to look for different ways of solving the same sentence and showing a special appreciation of students' explanations based on relations.

## STUDENTS' STRATEGIES

We describe here the strategies identified in the students' responses to the proposed number sentences<sup>1</sup>. They differ in the role of computation as well as in the moment of the solving process and the way in which students used relational thinking. We distinguish two group of strategies depending on the motivation that initially guided the strategy: (a) to make calculations to **F**ind and **C**ompare the numerical values of both sides (type FC), or (b) to **L**ook at the sentence and to **D**etect particular characteristics of it or relations between its elements (type LD).

Within the first group, we distinguish two different approaches. Sometimes students followed their initial tendency and solved the sentence by comparing the numerical values obtained (strategy type O, operational). Others, however, in the process of performing the calculation, students changed their strategy after appreciating some characteristic of the sentence or some relations between its terms, not previously noticed (strategy type IC, interruption of computation). This observation led them to solve the sentence without finishing the calculation. In these cases, initiating the calculation process served the student to become aware of the structure and elements of the sentence.

Within each of these approaches, we distinguish various strategies (see Figure 1) which we describe below. The strategies identified describe different ways in which relational thinking was used by the students to solve the proposed number sentences.

---

<sup>1</sup> Our identification of the strategy used by the students is based on their production, i.e., on their thinking made explicit through their explanations. It is not always possible to exactly determine which strategy was used in each case; an answer can sometimes be result of more than one strategy. This fact is mostly due to the briefness of some answers or to the occasional lost of temporality of the actions expressed by the students.

We observe that, although in some strategies type O there is not use of this type of thinking, in all the other strategies it is evidenced in some way. The sophistication of its use and the influence in it of the computation process is variable.

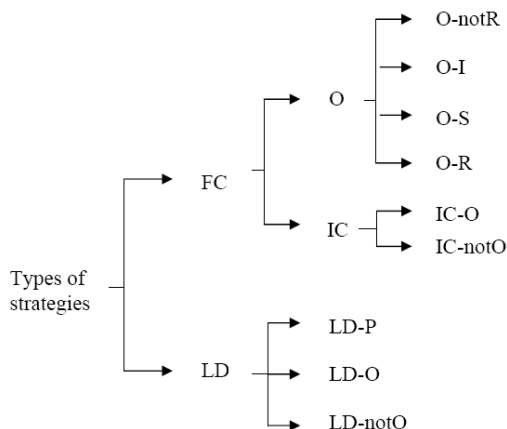

Figure 1. Classification of students' strategies.

### Strategies type O

In all strategies type O, students perform operations involved in the sentence and conclude the answer by comparing the numeric values obtained. Students display some dependence on the computation of the numeric values of each side in order to determine if the sentence is true or false. Within strategies type O, we distinguish four special ones: O-notR, O-I, O-S and O-R.

O-notR consists of performing the operations in both sides of the sentence without appreciating any relation or special characteristic of the sentence. In the strategy O-I, before doing any computation, students pay attention to the terms or operations in the sentence, in order to decide about the best way to approach the computation. This strategy evidences the simplest way in which the use of relational thinking was displayed. The following students' explanations suggest the use of these two strategies respectively:

“[In the sentence  $17 - 12 = 16 - 11$ ] true because I did one operation and the other and I got the same” (She computes  $17 - 12 = 05$  y  $16 - 11 = 05$  by the standard algorithm).

“[In the sentence  $19 - 3 = 18 - 2$ ] Cause two is less than three... [Researcher: Yes]... so, it is easier to subtract it, then I have subtracted eighteen minus two, which is easier, and I got sixteen, and the other nineteen minus three is sixteen”.

In the strategy O-S (sameness), the use of relational thinking is also fairly basic. O-S consists on the appreciation of sameness between the operations to perform in one side and those already performed in the other side, which allows avoiding some computation. This strategy evidences that part of the student's attention is not focus on

the computation, allowing him or her to distinguish sameness between the terms which is operating. For example, we identify a possible use of this strategy in the following explanation given to the sentence  $7+7+9=14+9$ : “I added seven plus seven, which gives fourteen, and plus nine is twenty-three. And, then, I have seen the fourteen plus nine and they are twenty-three”. In this case we need to pay attention to the student’s tone voice for noticing that she identified the operation on the right side as one of the operations previously performed when computing the numeric value of the left side.

In the strategy O-R, students detect some relations or characteristics of the sentence while or after computing the numeric values of both sides. This observation allows them to determine if the sentence is true or false by using some related arithmetic knowledge (not just number facts). When using this strategy, students provide two justifications of their answer: one based on the comparison of the numeric values of both sides and other based on the appreciated relations or characteristics. For example, we identify a possible use of this strategy in the following explanation given by a student to the sentence  $7+15=8+15$ : “False, because it doesn’t give the same, and because seven is smaller” (Aside she computes the numeric value of both sides by using the addition standard algorithm). This student appreciates a difference of magnitude between the numbers contained in both sides of the sentence.

Here the use of relational thinking is more sophisticated than the ones previously mentioned as students consider the sentence as a whole, make distinctions and appreciate relations between its terms. This use is dependent on the performance of the computation which helps the students to become aware of the components of the sentence and to relate them. This strategy also evidences some reliance on the comparison of the numeric values of both sides in order to decide and justify if the sentence is true or false.

### **Strategies type IC**

Like in the strategy O-R, strategies type IC evidence a use of relational thinking connected to performing some computations, as students appreciate relations or particular characteristics of the sentence through performing some computations. Students may be influenced by some tendency to operate which leads them to start computing before looking to the sentence or they may require computing for becoming aware of the structure of the sentence and the elements that it contains. However, in this case students abandon the computation initiated and don’t need it to determine and justify if the sentence is true or false.

We distinguish two strategies type IC, IC-O and IC-notO, depending on if the appreciated relations or characteristics lead the student to know the numeric value of both sides or not. The following students’ explanations suggest the use of these two strategies respectively.

[In the sentence  $257-34=257-30-4$ ] “False because instead of subtracting 34 they subtract 30 and the four goes aside” (Aside she uses the subtraction standard algorithm to calculate  $257-34=1223$ ,  $257-30=227$  and  $227-4=223$ ).



[In the sentence  $51 + 51 = 50 + 52$ ] “Because fifty-one plus fifty-one is one hundreds and two, but fifty-one, if you subtract [one], fifty, you can add [it] to the other fifty-one, one more, and you get fifty-two”.

### Strategies type LD

As previously explained, in strategies type LD students tackle the resolution of the sentence by observing it and looking for relations or especial characteristic of it. They display an initial disposition to use relational thinking and don't show any dependence on performing computations. So, we consider these are the strategies which display the most sophisticated use of relational thinking.

We distinguish between three strategies type LD. LD-O and LD-notO differ on if the appreciated relations or characteristics lead the student to know the numeric value of both sides or not. The following students' explanations suggest the use of these two strategies respectively:

[In the sentence  $125 - 125 = 13$ ] “False, because you subtract one hundred and twenty-five to one hundreds and twenty-five and it is zero, not thirteen [Researcher: How do you know that it is zero?] Because here there are the same numbers, and if you subtract the same numbers it is zero, here it cannot be thirteen”. He applies the property  $a - a = 0$  after observing the sameness of the terms in the left side.

[In the sentence  $75 + 23 = 23 + 75$ ] “True because in addition the order doesn't matter”. She notices the sameness of terms in both sides, although in different order, and use the commutative property to conclude the trueness of the sentence without needing the numeric value of both sides.

The other strategy, called LD-P (prediction) consists of the use of two strategies: (1) LD-O or LD-notO, to determine if the sentence is true or false, and (2) a strategy type FC to justify the answer to the sentence. We detect evidences of the use of this strategy in the interview to a student about the sentence  $11 - 6 = 10 - 5$ . Initially she concluded that the sentence was true after thinking for some seconds, but when we asked her why, she started computing the numeric values of both sides and said: “Because if you subtract six from eleven is...five, and if you subtract five to ten, five”. When being asked if she could explain it in other way, she referred to differences in magnitude between the terms in both sides: “Because... if eleven is higher than ten and you subtract one more than five, you get the same”. The way in which she provided this explanation, without taking time to think, suggests that she had previously appreciated this relationship.

### Discussion and Conclusions

We have described the strategies used, along the teaching experiment, by a group of third graders when solving number sentences based on arithmetic properties. We focused the analysis of these strategies on the use of relational thinking evidenced. Within the results, we want to highlight the different grades of sophistication detected in this use. The most basic ones are (a) paying attention to the structure and

composition of the sentence to decide about the best way to approach computations, as well as (b) appreciating sameness between the operations being done while computing. This use does not require recalling any special arithmetical property or principle. The most sophisticated use of relational thinking does not involve computing but considering the sentence as a whole, recognizing its structure and appreciating relations between its terms which allow solving the sentence.

Computation was identified as an important element for becoming aware of the composition of the sentence. Through the action of making computations, some elements or relations between elements “stood out to the students’ eyes”. Their attention got caught by some particularities of the sentence and then some related arithmetic knowledge got into play. Probably this dependence on (or tendency to) operating is consequence of the strong computational approach of traditional arithmetic teaching.

These results enrich our knowledge about elementary students’ use of algebraic ways of thinking in arithmetic context, which is key for the integration of both sub areas in the elementary curriculum. Although “thinking relationally while computing” is strongly valuable and desirable, in order to get students to use relational thinking in algebraic context, “thinking relationally without computing” need also to be promoted (as computation is not always possible when working with algebraic expressions).

### Endnote

This study has been developed within a Spanish national project of Research, Development and Innovation (I+D+I), identified by the code SEJ2006-09056, financed by the Spanish Ministry of Sciences and Technology and FEDER funds.

### References

- Bastable, V. & Schifter, D. (2007). Classroom Stories: Examples of Elementary Students Engaged in Early Algebra. In J. Kaput, D. W. Carraher, & M. L. Blanton (Eds.), *Algebra in the Early Grades*. Mahwah, New Jersey: LEA.
- Blanton, M. L. & Kaput, J. (2005). Characterizing a Classroom Practice that Promotes Algebraic Reasoning. *Journal for Research in Mathematics Education*, 36(5), 412-446.
- Carpenter, T. P., Franke, M. L., & Levi, L. (2003). *Thinking Mathematically: Integrating Arithmetic and Algebra in Elementary School*. Portsmouth: Heinemann.
- Carraher, D. W. & Schliemann, A. D. (2007). Early algebra and algebraic reasoning. In F. K. Lester (Ed.), *Second Handbook of Research on Mathematics Teaching and Learning*. (669-705). Reston, Virginia: NCTM e IAP.
- Cobb, P., Confrey, J., di Sessa, A., Lehrer, R., & Schauble, L. (2003). Design Experiment in Educational Research. *Educational Researcher*, 32(1), 9-13.
- Hoch, M. & Dreyfus, T. (2004). Structure sense in high school algebra: the effect of brackets. In M. Johnsen & A. Berit (Eds.), *Proceedings of the 28th International Group for the Psychology of Mathematics Education*, (Vol. 3, pp. 49-56). Bergen, Norway: Bergen University College.

- Hejny, M., Jirotkova, D., & Kratochvilova J. (2006). Early conceptual thinking. In J. Novotná, H. Moraová, M. Krátká, & N. Stehlíková (Eds.), *Proceedings of the 30th Conference of the International Group for the Psychology of Mathematics Education* (Vol. 3, pp. 289-296). Prague, Czech Republic: PME 30.
- Kaput, J. (1998). *Teaching and Learning a New Algebra with Understanding*. Dartmouth, Massachusetts: NCISLA
- Knuth, E. J., Alibali, M. W., McNeil, N. M., Weinberg, A., & Stephens, A. C. (2005). Middle School Students' understanding of core algebraic concepts: equivalence and variable. *Zentralblatt für Didaktik der Mathematik*, 37(1), 68-76
- Koehler, J. L. (2004). *Learning to Think Relationally: Thinking Relationally to Learn*. Dissertation research proposal, University of Wisconsin-Madison.
- Linchevski, L. & Livneh, D. (1999). Structural Sense: the relationship between algebraic and numerical contexts. *Educational Studies in Mathematics*, 40(2), 173-196.
- Molina, M. & Ambrose, R. (2008). From an operational to a relational conception of the equal sign. Thirds graders' developing algebraic thinking. *Focus on Learning Problems in Mathematics*, 30(1), 61-80.
- Molina, M., Castro E., & Ambrose, R. (2006). Trabajo con igualdades numéricas para promover pensamiento relacional. *PNA*, 1(1), 31-46.
- Molina, M., Castro, E., & Castro, E. (2007). Teaching Experiments within Design Research. *The International Journal of Interdisciplinary Social Sciences*, 2(4), 435-440.
- Slavit, D. (1999). The role of operation sense in transitions from arithmetic to algebraic thought. *Educational Studies in Mathematics*, 37(3), 251-274.
- Stephens, M. (2007). Students' emerging algebraic thinking in primary and middle school years. *Presented at the 30th Conference of the Mathematics Education Research Group of Australasia*.

# USE OF DEFINITION CONSTRUCTION TO HELP TEACHERS DEVELOP THE CONCEPT OF SLOPE

Deborah Moore-Russo

State University of New York at Buffalo

*Definition construction activities were incorporated into a mathematics education graduate course to help secondary preservice and inservice teachers, all with mathematics undergraduate degrees or the equivalent, more deeply understand the concept of slope and its connections in two- and three-dimensional mathematics. Findings of the study include: 1) defining was a new activity for the teachers; 2) teachers benefited from collaborative definition construction activities; 3) teachers' definitions were inefficient; and 4) few teachers had a profound understanding of slope or its connections in the mathematics curriculum.*

*Actividades de construcción de definiciones fueron incorporadas en un curso de educación de postgrado para ayudar a maestros de servicio y preservicio, todos con grados subgraduados en matemáticas, a entender profundamente el concepto de pendiente y las conexiones que este concepto tiene en matemática bidimensional y tridimensional. Entre otros hallazgo se encontró que 1) definir fue una actividad nueva para los maestros; 2) los maestros se beneficiaron de las actividades grupales de construcción de definiciones; 3) definiciones hechas por los maestros fueron ineficientes; y 4) pocos de los maestros tenía un entendimiento profundo del concepto pendiente o su conexión con el currículo de matemáticas.*

Ma's seminal work (1999) discussed the "profound understanding of fundamental mathematics" displayed by accomplished teachers. These accomplished teachers understood key concepts deeply and also had a well organized, rich web of connections among those concepts. Schoenfeld (2006) pointed out that Ma's ideas are both fundamentally mathematical and pedagogical. They emphasize the coherence and connectedness of mathematical structure. They also highlight teachers' roles as they guide students to make meaning of mathematical concepts, relations, and operations, while recognizing and fostering the connections among them. The study reported here investigated teachers' depth of understanding of the concept of slope and its connections in the mathematics curriculum in both two and three dimensions using collaborative definition construction activities as the primary means to help teachers unpack, investigate, refine, and connect their individual conceptions of slope.

## LITERATURE REVIEW

de Villiers (1998) suggested that teachers should be involved in definition construction activities pointing out that definition construction is a complex activity. He placed definition construction on equal footing with problem solving and proving. However, definitions in both mathematics and in mathematics education have

received relatively little research attention (de Villiers, 1998; Vinner, 1991; Zaslavsky & Shir, 2005). Freudenthal (1973) argued against teaching finalized geometry definitions without providing the learner any opportunity to engage in the defining process itself. Based on the results of many studies, preservice and inservice teachers' understanding of definitions (e.g. Fujita & Jones, 2007; Leikin & Winicki-Landman, 2001; Linchevski, Vinner, & Karseny, 1992; Pickreign, 2007) is limited. Most studies regarding definitions and the act of defining concentrate on elementary teachers. While the Leikin & Winicki-Landman (2001) study showed definitions as a means to enhance the mathematics needed for teaching secondary students, it involved discrete units of instruction rather than following a single concept to explore it deeply over a period of time. Learners need time to pass through the stages that are involved in understanding a complex concept (Vinner & Dreyfus, 1989). For that reason this study followed the concept of slope over a three month period.

## **THEORETICAL FRAMEWORK**

This study drew on the constructs of concept definition and concept image (Tall & Vinner, 1981; Vinner, 1991) to help frame the research. Concept definitions (or simply definitions) are the words used to specify a mathematical concept. A person can memorize a valid definition for a concept, but that is not an indication that the person understands this concept. Concept images (or simply images) are the nonverbal representations, mental pictures, and the associated properties built through a person's experiences and impressions over the years. Starting from childhood, images are frequently constructed in real life contexts without the use of definitions. In the case that a definition is used to form a concept, it is often discarded immediately after the person develops a concept image. In everyday life, this practice serves people well, but mathematical contexts require an emphasis on the definition rather than the image. Take a perpendicular bisector of a segment, for example. Just the words often provoke a mental picture without any thought about the definitions involved.

Images can contain coercive, misleading elements, especially in geometry. An image formed by experience is often at odds with the actual, theoretical geometric concept (Mariotti & Fischbein, 1997). For example, consider the difference between the theoretical concept of a line and the finite image usually used to represent this concept. Moreover, even if an image is not misleading, it is not always accessed in its entirety. When considering a mathematical concept, Tall & Vinner (1981) use the term "evoked concept image" to stress that a part of the memory is all that is often called on in a given situation.

## **METHODOLOGY**

The participants in this study were 14 preservice and inservice secondary mathematics teachers at a research university in the United States. All participants held a bachelor's degree in mathematics or its equivalent, and had successfully completed a geometry course and the calculus sequence including multivariable calculus as undergraduates. The participating teachers were mathematics education

graduate students (called teacher-students for the remainder of the paper) enrolled in an elective pedagogical content knowledge course. A main goal of the course was to help the teacher-students understand key mathematics topics traditionally taught in the secondary mathematics curriculum at a deep level through investigation of these topics in three dimensions. The teacher-students participated in the activities described as part of course requirements.

While all classroom discussions and group work sessions were videotaped (and will be used for more extensive reporting of the data in future works), only written artifacts produced by the teacher-students will be used for this particular paper. These artifacts, shown in the following table, were collected, compiled, and reviewed by the researcher-instructor and a graduate assistant over a three month period during the course of a single semester.

---

	As a part of a single in-class an assignment, teacher-students:
<i>Artifact 1</i>	a) Wrote an individual definition for slope
	b) Wrote an small group definition for slope
	c) Worked in small groups to trace the development and connections of slope in the K-16 mathematics curriculum
	As a part of a single in-class an assignment, teacher-students:
<i>Artifact 2</i>	a) Discussed and wrote why the slope might be considered a “big idea” across the K-16 mathematics curriculum
	b) Wrote how they felt about they time they spent in concept development through definition construction
	As a part of an course discussion board, teacher-students:
<i>Artifact 3</i>	a) Posted comments about the structure and nature of the course
	As a part of the final examination, teacher-students:
<i>Artifact 4</i>	a) Wrote a definition for slope

---

Table 1. Artifacts collected and used in the writing of this paper

Note that all the data collected in the four artifacts came after teacher-students had engaged in the creation of definitions for other mathematics concepts prior to developing definitions for the concept of slope. The teacher-students also had experienced an activity in which they compared their definitions with published definitions to see how different definitions could be equivalent and how some definitions were more economical that others before defining slope.

## SELECTED RESULTS

This section will present a small, yet representative, sample of the data collected. Note that each response is coded. The end code (which aligns with Table 1) refers to the artifact and its particular section that generated the response.

### **No Prior Experience with Definition Construction**

As evidenced by the following three responses and numerous verbal comments made to the instructor, definition creation was a new activity for the teacher-students. None of the teacher-students in the course had ever constructed a definition before.

I had never created definitions before but it was helpful and beneficial for me. It was difficult at times to think of the criteria for something to be true. The discussion this provoked amongst our group members was “deep” and insightful. This process was extremely thought provoking. I learned a lot from it. I definitely think this should be a part of any class. (A2b)

We have all had to read definitions but never really had to write them or explain them. By explaining definitions we learn the concept better. Also, there were bits of everyone’s definition that we all liked, so our overall definitions were a combined effort, allowing us to think of other possibilities. (A2b)

Most of the time a definition is simply given to us and we don’t take the time to understand where it came from. Writing your own definition and comparing it to others it becomes more meaningful and easier to understand. Sometimes it is a challenge, but usually ends up being better than a text book definition. (A2b)

### **Collaborative Group Interaction Perceived as Vital in Definition Construction**

As evidenced by the following three responses and instructor observations, teachers benefited not only from having to engage in the defining process as individuals, but the richest part of the experience seem to be in the group discussion to construct a definition. The third and final comment in this section hits at a common phenomenon for this particular class. The course officially ran from 7:00 p.m. to 9:40 p.m. This is rather late for teacher-students who have obligations during the day. Yet, often the instructor would have a student group (and this happened with more than one group) discussing the creation of a definition for a single concept for well over two hours staying until 10:30 p.m.; at that time the instructor would make students end their discussions so she could go home.

Before taking this class I obviously knew 3-D, but I didn’t really know how to explain it to anyone or to be able to visualize it very well. Each class helped me gain a better understanding of every concept. Many times when forming a definition I absent mindedly did not think of different scenarios. This is where the group came in handy. If I had been doing these activities by myself, I would have still learned the concepts. However, having different people’s perspectives on things helped out a lot for me. (A3a)

I appreciate the group discussion in developing the definitions of concepts. Often my individual definition is wrong or incomplete, but once we discuss the definition as a group I am able to add to it or change it to gain a clearer definition of the concept. These exercises has (sic) made me realize how difficult it is to write a clear, consise (sic), all-inclusive definition for a concept. (A2b)

I like the idea of concept development through definitions because it gives time to come up with your own idea and bounce it off of someone else. By developing your own ideas

you take responsibility for them. However there is a significant time restriction that may need to be addressed. When we start an interesting conversation it has to be cut short due to the time. (A2b)

### Deeper Understanding of Concept Does Not Imply Concise Definitions

While students seem to gain a better understanding of concepts after group discussions and as the semester progressed, this understanding did not help them write economical definitions as is evidenced by the following four responses. It is possible that some of the redundancy in the definitions may have stemmed from teacher-students being unaware of how to deal with slope in three dimensions and even if slope could be applied to figures other than lines.

Slope - For a line slope is the  $\frac{\text{rise}}{\text{run}}$ . In 2 dimensions this is  $\frac{\Delta y}{\Delta x}$ .

In 3 dimensions slope =  $\frac{\Delta z}{\text{change in horizontal distance along xy-plane}}$ . Given 2 points on the

line  $(x_1, y_1, z_1)$  and  $(x_2, y_2, z_2)$ , slope =  $\frac{|z_2 - z_1|}{\sqrt{(x_2 - x_1)^2 + (y_2 - y_1)^2}}$ .

Slope of a curve at a point - slope of a line tangent to curve at the point. (A1a)

The slope, to me, is the rate of change of a line. For straight lines it is constant everywhere on the line. It is the steepness. For a straight line it can be determined by the change in y values over the change in x values. (A1a)

The slope of a line is the rise over the run of a line.  $S = \frac{\text{rise}}{\text{run}}$ . This rise is the movement up or down on the y-axis in 2-space or up and down from the xy plane in 3-space (change in z). The run is the distance moved along the z-axis in 2-space or along the xy plane in 3-space. (A1b)

Slope is the pitch or steepness of a line or tangent to a point on a curve that is a quantitative measure of change which describes how rapidly a line, plane, or surface is increasing or decreasing. Slope has magnitude, sign, and units. Slope of a line or tangent has sign in 2-D. In 2-D lines that are parallel have equal slopes. Lines that are coplanar and have the same slope are parallel. (A1b)

### No Deep Understanding of Slope and Its Role in the Mathematics Curriculum

Although images are considered nonverbal, a case could be made that the written characters that form “rise/run” and “ $\frac{\Delta y}{\Delta x}$ ” had, in and of themselves, become evoked concept images. Teacher-students, when forced to think about slope outside of the common scenario of the slope of a line in two dimensions, demonstrated that they did not understand it deeply. Some moved on to work with directional slope when dealing with lines in three dimensions so that lines with equivalent slopes would always be parallel. These students seem to draw even more connections to then consider the slope of a plane in three dimensions in terms of the slope in the x direction and the slope in the y direction. This in turn formed rich connections to



partial derivatives. Other students rushed to find an equation that would find the slope of a line in three dimensions and were unconcerned about the direction of the line as long as they could find an answer.

It is the vertical change divided by the horizontal change, the rise over run,  $\frac{\Delta y}{\Delta x}$ . (A2b)

Slope is the change in y over (divided by) the change in x or  $\frac{(y_1 - y_2)}{(x_1 - x_2)}$ . (A2b)

Slope has many different terms. In 2-space it is simply the change in the y direction divided by the change in the x direction. In 3-space it changes because you are dealing with 3 variables. So the top part of the fraction is the change in z and is divided by the distance covered on the x-y plane ( $\sqrt{\Delta x^2 + \Delta y^2}$ ). This however means that many lines that are not parallel could have the same slope. So to remedy this problem you can use a rotational system so that the set of lines that have the same slope can be assigned different angle measures thus ensuring parallel lines will have exactly the same slope. (A4a)

Even the act of definition creation seemed to help students strip a concept down to its key elements. A few students had enough self realization to see that they did not understand slope deeply outside of its traditional context.

Creating definitions helped me understand and generalize all the essential aspects of a concept so that they were included in my definition. (A2b)

I feel that I have a better understanding of most of these concepts because of writing the definitions but I don't have that deep understanding of some of these concepts even though I wrote definitions. It does give me good practice at getting to the basics of the concepts in order to write simple definitions for future students. (A2b)

The collaborative definition creation activities when coupled with group activities to trace the development and connections of slope in the mathematics curriculum seemed to be of great benefit in helping teacher-students develop a more profound understanding of slope. Each small group included either fractions or proportional reasoning as a concept in younger grade levels that extended to slope and the concepts of parallel, tangent lines, and derivatives as extending from slope as the curriculum moved to higher grade levels. One group even included slopes of surfaces, slope fields, and correlation coefficients on the diagram its members made as being connected to slope.

Creating definitions was beneficial because it makes students formulate connections across various mathematical concepts. It worked best when we wrote individually, shared our thoughts, discussed, discussed, discussed, and finally wrote a definition. (A2b)

Slope is a big idea in mathematics because it measures change between two variables which lays the groundwork for functions modelling change. Once you have functions modelling change, you can analyse the change. Comparing slopes indicates the relationship of one change to another change. (A2a)

## DISCUSSION

Due to space limitations, we will forego any discussion regarding the concept of slope and teachers' understanding of this concept. Rather, the discussion will focus on definition construction. Ten years after de Villiers (1998) asked the mathematics education community; "Should we teach definitions or teach to define?" it seems that definition construction activities should be more prevalent, especially in the education of mathematics teachers. Definition construction activities serve dual purposes by enriching a learner's concept of definition in mathematics (Borasi, 1992) as well as the learner's development of a specific mathematical concept (Ouvrier-Bufferet, 2006).

The results of the study in this paper support Zaslavsky & Shir's (2005) findings the "the mere need to consider an alternative definition of a specific concept evoked interactions between students' concept images and their personal definitions of the defined concept. These interactions led to refinements of students' understandings of the defined concept (p.338)." However, the combined sample of students in this study and in the Zaslavsky and Shir study is under twenty. Additional studies need to be carried out that investigate how collaborative definition construction can influence how a learner understands a concept, both in terms of its definition and its image. Would the impact on the learner be as great if the definition construction activities were not done in collaboration with peers?

There is more literature on the definition construction of geometric figures rather than on attributes of geometric figures (e.g. slope) and the relationships between geometric figures (e.g. intersections). While slope and intersections are just two examples, there are many key concepts that can be traced across the K-16 mathematics curriculum that are worthy of study. One reason why there are fewer studies on the attributes and relationships of geometric figures may be in part to the fact that few studies have been conducted using secondary mathematics teachers. Additional studies need to look at this population and how their understanding of mathematics concepts and their interpretation of the importance and role of definition in school mathematics changes after engaging in collaborative definition construction activities. Does this extended engagement in a definition construction environment affect teachers' practice of teaching?

Finally while concise definitions are seen as superior by many in mathematics; is that, or maybe, should that be the case in mathematics education?

## References

- Borasi, R. (1992). *Learning Mathematics Through Inquiry*. Portsmouth, NH: Heinemann.
- de Villiers, M. (1998). To teach definitions in geometry or teach to define? In A. Oliver & K. Newstead (Eds.), *Proceedings 22<sup>nd</sup> Conference of the International Group for the Psychology of Mathematics Education* (Vol. 2, pp. 248-255). Stellenbosch, South Africa: PME.

- Freudenthal, H. (1973). *Mathematics as an Educational Task*. Dordrecht, The Netherlands: Reidel.
- Fujita, T. & Jones, K. (2007). Learners' understanding of the definitions and hierarchical classification of quadrilaterals: Towards a theoretical framing. *Research in Mathematics Education* 9(1and2), 3-20.
- Leikin, R. & Winicki-Landrum, G. (2001). Defining as a vehicle for professional development of secondary school mathematics teachers. *Mathematics Education Research Journal* 3, 62-73.
- Linchevski, L., Vinner, S., & Karsenty, R. (1992). To be or not to be minimal? Student teachers' views about definitions in geometry. In *Proceedings 16<sup>th</sup> Conference of the International Group for the Psychology of Mathematics Education* (Vol. 2, pp. 48-55). Durham, New Hampshire: PME.
- Ma, L. (1999). *Knowing and Teaching Elementary Mathematics*. Mahwah, NJ: Lawrence Erlbaum.
- Mariotti, M. A. & Fischbein, E. (1997). Defining in classroom activities. *Educational Studies in Mathematics*, 34, 219-248.
- Ouvrier-Buffet, C. (2006). Exploring mathematical definition construction processes. *Educational Studies in Mathematics* 63, 259-282.
- Pickreign, J. (2007). Rectangles and rhombi: How well do preservice teachers know them? *Issues in the Undergraduate Mathematics Preparation of School Teachers Vol. 1*, (February 2007), retrieved January 12, 2008 from <http://www.k12prep.math.ttu.edu/journal/contentknowledge/pickreign01/article.pdf>
- Schoenfeld, A. (2006). Mathematics teaching and learning. In Alexander, P. A. & P. H. Winne (Eds.) *Handbook of Educational Psychology*, 2<sup>nd</sup>. Ed. (pp. 479-520). Mahwah, NJ: Lawrence Erlbaum.
- Tall, D. & Vinner, S. (1981). Concept image and concept definition in mathematics, with particular reference to limits and continuity. *Educational Studies in Mathematics*, 12, 151-169.
- Vinner, S. (1991). The role of definitions in teaching and learning of mathematics. In Tall, D. (Ed.), *Advanced Mathematical Thinking* (pp. 65-81). Dordrecht, The Netherlands: Kluwer
- Vinner, S. & Dreyfus, T. (1989). Images and definitions for the concept of function. *Journal for Research in Mathematics Education*, 20(4), 356-366.
- Zaslavsky O. & Shir, K. (2005). Students' conceptions of a mathematical definition. *Journal for Research in Mathematics Education* 36(4), 317-346.

# TEACHERS' ATTRIBUTIONS OF LANGUAGE PROFICIENCY, MATHEMATICS ACHIEVEMENT, AND SCHOOL CONTEXT MEASURES: AN EXPLORATORY STUDY

Eduardo Mosqueda and Kip Téllez

Both University of California

*This study examines the mathematics achievement of Latino native English speakers compared to non-native English speakers in U.S. high schools. We specifically focus on how academic tracking can influence mathematics achievement and, at the same time, whether having access to a mathematics teaching with specialized training in teaching English as a Second Language (ESL) students can help mitigated the negative impact of tracking on their mathematics achievement outcomes. Using the Education Longitudinal Study of 2002 (ELS:2002) dataset, we analyze a nationally representative sub-sample of 2,234 immigrant and non-immigrant Latino 10<sup>th</sup> graders. We use Hierarchical Linear Models (HLM) regression analysis to fit multi-level models that describe each student's mathematics achievement as a function of: 1) their English proficiency, 2) their placement in a general or academic track in school, 3) whether they are provided with native language support, and, 4) the teacher's attributions regarding the role of language in mathematics achievement. By illuminating the effects of academic tracking of Latino English learners, this research will help us address the achievement gap in math test scores between Latinos and Whites and among English proficient and non-proficient Latino students.*

## INTRODUCTION

The mathematics achievement scores of *all* Latinos on the National Assessment for Educational Progress (NAEP) have been described as “pervasively, disproportionately, and persistently low” over time, relative to similar outcomes for whites (Valencia, 2002). The scores of Latinos that are not proficient English-speakers are significantly lower (Abedi & Lord, 2001). Yet, there is a long-standing myth in mathematics education that the level of English proficiency of students is not an issue in instruction because mathematics is a "universal language." As a result, many educators assume that a student's English proficiency has a minimal effect on learning mathematics (Flores, 1997; Gutierrez, 2002). However, recent research suggests that the English proficiency of Latino English Learners (ELs) plays a critical role in their learning of mathematics, particularly for ensuring that they are able to comprehend, and then apply, complex mathematical concepts (Garrison & Mora, 1999; Moschkovich, 1999). About one in ten public school students in the U.S. were Spanish-speaking ELs (Kindler, 2002). Their poor achievement in mathematics suggests that meeting the linguistic and academic needs of Latino ELs is a critical issue in our schools and, consequently, for educational research, policy and practice (August & Hakuta, 1997).

In our study, we examine how: 1) the level of English proficiency of students, 2) academic tracking, 3) the mathematics teacher's ability to support English learners,

can simultaneously influence the mathematics achievement of Latino native and non-native English speakers, and 4) the teacher's attributions regarding the role of language in mathematics achievement. We also assess whether these relationships differ for Latino ELs as compared to their native English-speaking and English proficient Latino peers. We hypothesize that the low-track placement of Latinos with low-levels of English proficiency has a greater compounded (interactive) negative effect on their mathematics achievement than on their English-speaking peers. We also suspect that the negative effect of academic tracking on mathematics achievement can be moderated in cases where students have access to a mathematics teacher with specialized training in teaching English as a Second Language (ESL).

## **BACKGROUND THEORY**

Latino students as whole, irrespective of their level of English proficiency, repeatedly underachieve in U.S. public schools. For example, in 1992, the average NAEP mathematics scores for Latino eighth graders fell between the average scores of White fourth and eighth graders, suggesting that the mathematics skills of Latinos were as much as two years behind White eighth-grades (Smith 1995). Moreover, between 1972 and 1992, a separate NAEP-score analysis revealed only *small gains* in the lower cognitive areas of knowledge, such basic computational skills, for Latinos while their performance in applications and complex problem-solving remained stagnant (Secada, 1992; Tate, 1997).

English proficiency is an important factor given the considerable research arguing that mathematics is itself a language that is more complex than everyday English (Gutierrez, 2002). The language of mathematics is described as a "register" of words and meanings that differ from those of everyday language (Secada, 1996). For example, the language of mathematics has specialized meanings for words and phrases such as "horizontal," "vertical," "subtract," etc., that differ from the conversational and academic meanings (Khisty, 1995). Furthermore, as ELs become proficient in everyday English (which is not sufficient for success in mathematics), they must also learn the complex language of mathematics. This suggests that ELs require considerable support in both their first and second language to cope with the linguistic demands of learning advanced mathematics in their non-dominant language.

Whereas teachers' attributions of student success have been studied in a wide variety of settings (McAllister, 1996; Fennema, Peterson, Carpenter, & Lubinski, 1990; Tschannen-Moran, Woolfolk Hoy, & Hoy, 1998), we found no studies in which teachers' expectations of mathematics performance was linked to language proficiency. Our current study explores the relationship between student test score data and a survey item inviting teachers to rate whether a student's performance is owing to limited English proficiency.

Educational researchers have examined the role that institutional factors, such as tracking, play in structuring the academic success and failure of Latino ELs (Gandara, 1999; Valenzuela, 1999). Recent research has found that English

proficiency factors significantly into their track placement (Harklau, 1994). Scholars have argued that having a low-level of English proficiency is considered a “deficit” (Gutierrez, 2002) and, as a result, ELs have limited access to advanced mathematics courses (Flores, 1997).

The placement of Latino ELs in lower-track classes raises important questions about the rigor of the curriculum in their classes. Research has found the low-level track curriculum to be cognitively undemanding and focused on memorization and repetition (Oakes, 1995). In contrast, research has documented several educational advantages from placement in high-track classes. Research on tracking has shown that even acquiring English fluency was rarely a guarantee for promotion into the high-track, instead Latino ELs are typically moved from the low-track ESL classes to the English-only low-track (Valenzuela, 2001).

Recent findings show that Latino ELs experience higher levels of success in secondary school mathematics courses that provide native language support (Moschkovich, 1999). Dentler and Hafner (1997) found that districts that successfully educated Latino ELs were more likely to have well-established language programs that used “the student’s primary language to build comprehension” (p. 67).

The aforementioned literature found that low-track placements negatively impact students’ achievement in mathematics. While some studies analyze *whether* tracking impacts mathematics achievement, no studies have examined *how* track placement and English proficiency interact to impact mathematics achievement for this population, particularly at a national level. We address this limitation in our paper.

Our research is guided by the following research questions, each of which applies only to the population of tenth-grade Latino high school students:

1. Does the impact of academic tracking on mathematics achievement differ for Latinos with high and low levels of English proficiency?
2. Is the disproportionate disadvantage to Latinos with low English proficiency in the low academic tracks mediated by the presence of linguistic supports, specifically the presence of mathematics teachers with specialized training in teaching ELs? And does the teacher’s attribution of achievement to the level of English proficiency of students influence their mathematics achievement?

In study we use the first wave of the Educational Longitudinal Study of 2002 (ELS:2002). The first wave of the ELS:2002 dataset is ideal for this analysis since it contains policy-relevant trend data about critical transitions experienced by tenth-grade students as they proceed through high school. We analyze a sub-sample of 2,234 Latino immigrants and their U.S.-born Latino counterparts. We use two-level hierarchical linear models (HLM) analysis and fit multi-level models to investigate the effect of select school-context variables (Level-2) on the mathematics achievement of students (Level-1) in ELS:2002. Multi-level modeling is well suited for this analysis due to the clustering of students within classrooms.

We also include a series of control Predictors in order to account for individual background and classroom variation. We control for individual-level gender, parental education and income, and immigrant student's prior level of education (in their native country) and their age of arrival to the U.S. At the classroom level, we control for the mathematics teacher's educational background and years of teaching experience

## FINDINGS

To address our first research question, we used HLM to fit multi-level models to investigate how English proficiency, academic track placement and their statistical interaction impact the mathematics achievement of Latinos. We fit multilevel model 5 (in Table 1), and our analysis reveals statistically significant interactions among the English and tracking variables, suggesting that the impact of academic tracking on the mathematics test scores of Latinos *does* differ as a function of the level of English proficiency of non-native English speaking Latinos. Due to the complexity in the interpretation, we present these findings graphically in Figure 1, for students *with* credentialed teachers who also have a background in mathematics, and holding all other control predictors constant.

Given the nature of interaction terms, we cannot interpret these coefficients alone. Rather, they must be interpreted in conjunction with the main effects of the English proficiency and tracking predictors. The test scores of Latinos non-native speakers in college preparatory track are quite revealing. While Latino non-native speakers in the college preparatory track with *high* levels of English proficiency score as high as native English speakers in the same high track, the test scores of those with *low* levels of English proficiency are much lower than even the lowest scoring students in the general track, the Latino ELs.

More specifically, the results show that, on average, English proficiency is much more important for predicting mathematics achievement for non-native English speakers in the college preparatory track, than it is for non-native English speakers in the general track. Interestingly, the mathematics scores of non-native English speakers with *low-levels* of English proficiency in the college track are lower than the mathematics scores of non-native English speakers with equally low-levels of English proficiency in the general track. However, the mathematics achievement scores of non-native English speakers with *higher-levels* of English proficiency are, on average, equal to the test scores of native English speakers in the college track and.

It is important to note the stark difference between low-English proficiency students in the college track are slightly over one standard deviation below the mean achievement of native English speakers in the college preparatory track.

In response to research question 2, our results indicate that non-native English speakers with access to a mathematics teacher with at least eight hours of specialized LEP training in the last three years does not have a significant impact on their mathematics achievement when controlling for students' background characteristics, their mathematics teacher's preparation, and selected school context measures.

## **DISCUSSION AND CONCLUSION**

Our analysis shows that the impact of tracking does vary as a function of the level of English proficiency of non-native English-speaking Latinos. Our findings show that the impact of academic track placement on mathematics test scores of Latinos indeed differs by the level of English proficiency all non-native English speakers. For instance, Latino English Proficient Students (EPSs) in the college preparatory track scored at levels equal to Latino Non-native English Speakers (NESs) also in the college preparatory track. In stark contrast, Latino ELs that were also in the college preparatory track were the lowest performers on the ELS:2002 assessment. These findings show that the English proficiency level of non-native English speakers is extremely important in predicting their achievement in mathematics. For Latino ELs in the college track in particular, English proficiency seems to be critically associated with their achievement.

Our initial hypothesis was that Latino ELs in the general track would face greater disadvantage, and thus have lower mathematics scores, due to their exposure to low-level basic mathematics content, as compared to Latino ELs in the college preparatory track. Latino ELs in the general track were indeed disadvantaged and had lower mathematics assessment scores than Latino EPSs in the same low-level track. However, as compared to Latino ELs in the college preparatory track, Latino ELs (with equally low levels of English proficiency) in the general track had higher mathematics test scores, which is different than what we had originally hypothesized.

While surprising, this finding is supported by the research reviewed earlier which argued that the sophisticated mathematics-specific discourse and the complexity of the rigorous mathematics content itself demands a high degree of English proficiency. According to prior research, ELs have done well in rigorous mathematics courses when native language support was provided for them during instruction.

Latino EPSs outperform other Latino EPSs in the general track with equally high levels of English proficiency. Additionally, it was found that Latino EPSs in the college preparatory track performed at equally high levels as Latino NESs in the same track-level. This finding shows that while having a low level of English proficiency can disadvantage students in the college preparatory track, when students acquire a high level of English proficiency, they benefit much more from their placement in rigorous college preparatory courses than from placement in the general track.

Because Latino ELs in the general track had slightly higher test scores than Latino ELs in the college preparatory track, these findings might imply that they are more “appropriately” placed in lower level classes. However, this study strongly suggests that such placement decisions are not optimal given that Latino EPSs in the college preparatory track reached the mathematics test scores of the highest performing Latino students in the sample—the Latino NESs in the college preparatory track. This was so in spite of the lower achievement scores of Latino ELs in the college preparatory track.



This also suggests that the placement non-native English speakers in the general track disadvantages them once they acquire English proficiency since they will likely remain in low-level track courses that teach unchallenging basic mathematics skills. Our point here is that the English proficiency level of Latino ELs will invariably improve over time but if they are relegated to remedial mathematics instruction in the general tracks they will not fully reap the academic benefits of English proficiency nor will they reach their full potential in mathematics.

Finally, our original hypothesis was that the presence of a teacher with specialized LEP training would mediate higher Latino EL mathematics test scores. However, the presence of teachers with specialized LEP training did not have an impact on the assessment outcomes of Latino ELs. This finding, however, is not conclusive since the measure of the linguistic training of teachers was very crude. The survey asked whether “teachers had at least 8 hours of specialized training over the last 3 years” in working with ELs. If teachers reported that they had such training, this could mean that they attended only a one-day (eight-hour) workshop for training on teaching ELs over the last three-year period. However, this could also mean that a teacher earned a degree in teaching ELs. Given the clear imprecision of this measure, more work is needed to create a more reliable measure of specialized linguistic training for future data collection. A more valid measure would be very useful for future studies on this topic in light of the fact that the rapid growth of Latino ELs and the political debates contesting whether or not native language support should be provided for them.

## References

- Abedi, J. & Lord, C. (2000). The Language Factor in Mathematics. *Applied Measurement in Education*, 14(3), 219-234.
- August, D. & Hakuta, K. (1997). *Improving Schooling for Language-Minority Children: A Research Agenda*. Washington, D.C.: National Research Council, Institute of Medicine, National Academy Press.
- Gandara, P. (1999). Staying in the Race: The challenge for Chicanos in Higher Education. In J. F. Moreno (Ed.), *The Elusive Quest for Equality: 150 Years of Chicano/Chicana Education*. Cambridge, MA: Harvard Educational Review.
- Garrison, L. & Mora, J. K. (1999). Adapting Mathematics Instruction for English Language Learners: The Language Concept. In L. Ortiz-Franco, N. G. Hernandez, & Y. De La Cruz. Reston (Eds.), *Changing the Faces of Mathematics: Perspectives on Latinos*. VA, National Council of Teachers of Mathematics.
- Gutierrez, R. (2002). "Beyond Essentialism: The Complexity of Language in Teaching Mathematics to Latina/o Students." *American Educational Research Journal* 39(4), 1047-1088.
- Harklau, L. (1994a). "Jumping Tracks": How Language-Minority Students Negotiate Evaluations of Ability. *Anthropology & Education Quarterly* 25(3), 347-363.
- Khisty, L. (1995). Making Inequality: Issues of language and meanings in mathematics teaching with Hispanic Students. In W. G. Secada, E. Fennema, & L. B. Adajian (Eds.),

*New Directions for Equity in Mathematics Education*. New York, NY: Cambridge University Press.

Moschkovich, J. (1999b). Understanding the Needs of Latino Students. In L. Ortiz-Franco, N. G. Hernandez, & Y. De La Cruz Reston (Eds.), *Changing the Faces of Mathematics: Perspectives on Latinos*. VA, National Council of Teachers of Mathematics.

Oakes, J. (1985). *Keeping Track: How Schools Structure Inequality*. New Haven: Yale University Press.

Secada, W. G. (1992). Race, Ethnicity, Social Class, Language, and Achievement in Mathematics. In D. A. Grouws (Ed.), *Handbook of Research on Mathematics Teaching and Learning*. New York, NY: McMillan Publishing Company.

Valencia, R. R. (Ed.). (2002). *Chicano School Failure and Success: Past, Present, and Future* (Second Edition ed.). New York, NY: Routledge/Falmer.

Valenzuela, A. (1999). *Subtractive Schooling: U.S.-Mexican Youth and the Politics of Caring*. Albany, NY: State University of New York Press.



# MODELING WITH DATA IN CYPRIOT AND AUSTRALIAN PRIMARY CLASSROOMS

Nicholas G. Mousoulides

University Of Cyprus

Lyn D. English

Queensland University of Technology

*This paper addresses the mathematical developments of two classes of ten-year-old students in Cyprus and Australia as they worked on a complex modeling problem involving interpreting and dealing with multiple sets of data. Modeling problems require students to analyse a real-world based situation, pose and test conjectures, and construct models that are generalizable and re-usable. Our findings show that students in both countries, with different cultural and educational backgrounds and inexperienced in modeling, were able to engage effectively with the problem and, furthermore, adopted similar approaches to model creation. The children progressed through a number of modeling cycles, from focusing on subsets of information through to applying mathematical operations in dealing with the data sets, and finally, identifying trends and relationships.*

## INTRODUCTION

The need to work successfully with complex data systems in our world has never been greater. Primary school students are very much a part of our data-driven society: they have early access to computer technology and daily exposure to the mass media where various data displays and related reports can easily mystify or misinform, rather than inform their young minds. More than ever before, we need to rethink the nature of the mathematical problem-solving experiences we present to children if we are to prepare them adequately for dealing with the complexity of our rapidly changing world (English, 2007; Lesh & Zawojewski, 2007).

Traditional forms of problem solving constrain opportunities for children to explore complex, messy, real-world data and to generate their own constructs and processes for solving authentic problems (Hamilton, 2007). In contrast, mathematical modeling provides rich opportunities for children to experience complex data within challenging, yet meaningful contexts.

This paper reports on the mathematical developments of two classes of 10-year-old children, one in Australia, and one in Cyprus, as they worked a data modeling problem that involved interpreting and dealing with multiple tables of data, exploring relationships among data, using proportional reasoning and the notion of rate, and representing findings in visual and written forms. The children were of different cultural and educational backgrounds and were new to mathematical modeling of this nature. We were particularly interested in exploring and comparing the ways in which the two classes interpreted and approached the problem and how they mathematized the data in developing their models.

## **MATHEMATICAL MODELING FOR THE PRIMARY SCHOOL**

Mathematical models and modeling have been defined variously in the literature (e.g., Gravemeijer, 1999; Greer, 1997). We adopt the perspective that models are “systems of elements, operations, relationships, and rules that can be used to describe, explain, or predict the behavior of some other familiar system” (Doerr & English, 2003, p.112). Modeling problems engage children in mathematical thinking that extends beyond the traditional curriculum. Typical classroom mathematics problems present the key mathematical ideas “up front” and children select an appropriate solution strategy to produce a single, usually brief, response. In contrast, modeling problems embed the important mathematical constructs and relationships within the problem context and children elicit these as they work the problem. The problems necessitate the use of important, yet underrepresented, mathematical processes such as constructing, describing, explaining, predicting, and representing, together with quantifying, coordinating, and organizing data (Mousoulides, 2007). Furthermore, the problems allow for various approaches to solution and can be solved at different levels of sophistication, enabling all children to have access to the important mathematical content (Doerr and English, 2003; English, 2006).

Unlike typical school problems, modeling activities are inherently social experiences, where children engage in small-group collaborative work and are motivated to challenge one another’s thinking and to explain and justify their ideas and actions (Zawojewski, Lesh, & English, 2003). Numerous questions, issues, conflicts, revisions, and resolutions arise as children develop, assess, and prepare to communicate their solutions to their class peers.

### **DESCRIPTION OF THE STUDY**

#### **Participants and Procedures**

The Australian participants were a class of 30 ten-year-olds and their teacher, who participated in a 3-year longitudinal study of children's mathematical modeling (English, 2006). The children were from a co-educational private, K-12 school. The participants from Cyprus involved one class of 22 ten-year-olds and their teacher, who are presently participating in a similar longitudinal study. The students are from a public K-6 primary school in the urban area of the capital city of Nicosia.

The data reported here are from the first year of the respective studies and are drawn from one of the problem activities the children completed during this first year. The modeling problem (the *Aussie Lawn Mower Problem*) appears in the appendix (adapted from Hjalmarson, 2000). The first author translated the problem into Greek for the Cypriot children. The problem entails: (a) a warm-up task comprising a mathematically rich “newspaper article” designed to familiarize the children with the context of the modeling activity, (b) “readiness” questions to be answered about the article, and (c) the problem to be solved, including the tables of data. Only the background information, the problem itself, and the initial part of each data table appear in the Appendix. Mathematical modeling problems of the present type were

new to the children, although both the Australian and Cypriot children were familiar with working in groups and communicating their mathematical ideas to their peers.

The problem was implemented by the authors, the classroom teachers, and two pre-service teachers in each country. Working in groups of three to four, the children spent four 40-minute sessions on the activity. During the first session the children worked on the newspaper article and the readiness questions. In the next three sessions the children developed their models, wrote their letters that explained their models, and presented their work to the class for questioning and constructive feedback. A class discussion followed that focused on the key mathematical ideas and relationships the children had generated.

### **Data Sources and Analysis**

The data sources included audio- and video-tapes of the children's responses to the problem activities, together with their worksheets and our own field notes. The transcripts were reviewed by the authors to identify and compare developments in the model creations of the two classes with respect to: (a) the ways in which the children interpreted and understood the problem, (b) their initial approaches to dealing with the data sets, and (c) the ways in which they selected and categorized the data sets, and applied mathematical operations in transforming data.

We report here on the children's developments in terms of the cycles of increasing sophistication of mathematical thinking that we identified, with each cycle representing a shift in the children's thinking (Doerr and English, 2003).

## **RESULTS**

### **Cycle 1: Focusing on Subsets of Information**

During this cycle the children focused only on some of the problem data and information. This resulted in a number of initial, interesting approaches to model development but these approaches were inadequate because the students did not take into account the whole problem data.

Each of the groups in Australia commenced the problem by scanning the tables of data to find employees who scored highly in one or more of the categories (i.e., hrs worked, no. of lawns mowed etc.). Similarly, in the Cypriot site, all groups began the problem by scanning the data tables to find the best employees in each table. This appeared to be problematic, as students focused their attention on different employees and therefore could not agree upon the best ones. Limited mathematical thinking was displayed in this unsystematic approach, as evident in many groups' comments in both countries. For example: *"Also, I think Jonathon is good because he works top hours and doesn't drive much. Also mows quite a lot of lawns and makes a bit of money..."*; *"Look at Matthew... he is really good in mowing big lawns and he is working many hours"*.

While most groups in both countries initially used this unsystematic approach, one Australian group and two Cypriot groups decided to choose employees "with

different specialities” and remained with this decision in developing their model. Students from Australia commented that: *“We’ll get Travis to work at the shop selling fertilizers and all that. He could work from 8 to 5—that’s about 9 hours ... he earns the most money ... Matthew could work ... because mowing is a lot...Jonathon could do the small lawns.”* The fact that four tables were provided and students had to select four employees, seemed to encourage students to select one employee from each table (e.g., one who worked most hours, one who travelled most kilometres, one who mowed the greatest number of lawns and finally one who earned top money). An example of students’ discussion in one Cypriot group here appears below:

Chris: Jonathan is the best here (referred to the hours worked table) ... Travis travels always more than 200 km. He is the second one.

Mary: Matthew also travels more than 200 km every month.

Chris: You are right, but Travis travels more. But, do not worry. Matthew is the best in the lawns table.

Alex: Is he? He is only good to do the big lawns.

With the exception of two groups in Australia, none of the groups commenced the problem by considering whether some items of information were more important than others or whether some information might be irrelevant. One of the groups in Cyprus based their employee selection only on the results from the lawns mowed table. These students explicitly reported that the number of lawns mowed was more important than data from other tables, but they failed to explain why. In both countries the children did, however, engage in heated debates over how to interpret “kilometres driven” and whether more kilometres driven indicated a more desirable employee. The children used their informal knowledge to make a number of conjectures and justify their claims: *“We’re looking at how many kilometres you drive in a truck that’s owned by them; that’s bad”*; *“No, Company truck. It costs a lot of money to have company trucks”*; *“Is it good that he drove so many kilometres?”*; *“His employee might have asked from him to mow lawns in Paphos (a Cypriot city far away from the children’s school)”*.

Because the problem purposefully lacked some information, groups in both countries frequently brought in additional ideas and assumptions based on their real-world knowledge (e.g., hours the garden shop should open; how much customers should be charged; how much the employees should be paid). Additionally, many of the students in Cyprus were confronted with difficulties in understanding the hours worked table. A possible reason for this might be the fact that most people in Cyprus work on a full-time and not on a per-hour basis. As a result, many Cypriot children considered “more hours” as a characteristic of good employees and did not think of dealing with it as a “part of a ratio”. Because most of the groups in both countries did not use any systematic approach to tackle the problem initially, they frequently argued over which employees should be chosen. This led them to see the need to mathematize, in some way, their employee selection. The groups began to use two main mathematical operations to aggregate the data for each employee, namely, (a)

simply totalling the amounts in each category (hours worked, kilometres driven etc.) and ranking the employees, and (b) finding the average for each category. The latter was not the case for students who worked the problem in Cyprus. A possible reason is that the children were not formally taught the concept of average in their year level (this was also the case for the Australian children). A number of Cypriot students were, however, aware of the notion and, as they pointed out in the whole-class discussion, they could find the average for each category.

## Cycle 2: Using Mathematical Operations

Quite quickly, students realized that their initial approaches were not successful, since a number of contradictions arose in their results. Consequently, almost all groups in both countries moved to mathematizing their procedures by totalling the amounts in each table and, for the Australian students, by finding the averages. This was a significant shift in the students' thinking. In one Australian group, for example, Joanne challenged the other members of her group on their unsystematic approach and justified her decision by explaining, "*Well, it's kind of difficult working out how much they worked each month. Sometimes they worked less and sometimes more.*" Following this, the students proceeded to work out the average number of hours worked, lawns mowed (treating, 'big,' 'medium,' and 'small' separately), kilometres driven, and money from products sold for each employee.

Once all the averages had been found, this Australian group did not progress further. They selected those employees who scored high averages across all categories, explaining in their report: "*Well, we worked out the average for average money per week from the products sold and looked for the 4 highest and did the same for the hrs worked.*"

The Cypriot students' approaches here were slightly different to the Australian students. While working the problem, none of the Cypriot groups used the concept of average or treated separately the different lawn sizes. Almost all groups ranked the employees in each table based on totalling the data for each employee. A slightly varied approach was used by one Cypriot group: adopting an assumption that data provided in the lawns mowed table was more important than data from other tables, the group selected the best four employees from the lawns mowed table and then checked whether these employees were also among the best in the other three tables:

Lena: What is the most important? Mowing lawns, right? [...] Well, Travis is first ... 218 and Aaron 216. These two are the best.

Gina: We need two more employees. Who's next? Cynthia has 195.

Lena: Yes, she is third. And Jonathan mowed 187 lawns.

Gina: Now, let's see if these are the best in the money collected table ... Travis, Kim, Jonathan and Aaron. Only Cynthia is not among the best here!

At the same time, substantial discussion and argumentation took place when the group members tried to convince each other of their selections and their proposed models. Lively discussion also occurred when students misinterpreted data from



different tables and their group's members tried to explain and convince them of a more appropriate interpretation (e.g., trying to convince others that the table of money from products sold was not money the company *paid to its employees.*)

### **Cycle 3: Identifying Trends and Relationships**

In both countries, students progressed to looking for trends in their data sets to help them choose the employees. However, they were not as successful in identifying more generalizable trends and relationships across different tables. Rather, most of the identified trends focused only within single tables (e.g., across different months or across different lawn sizes) although in the Australian site, two of the groups looked for trends and relationships across tables. One group, for example, initially explored trends within a table (e.g., "*Kim is always gaining... 200, 250, 256*" [in the money collected table]). This led the group to compare trends across categories: "*So Travis should be our first guy. He may have done 5 less hours than Jonathon, but he did more jobs.*" The students did not progress to the notion of rate, however, in part because they kept conjecturing about why the trends occurred (e.g., "*With the lawns mowed, they hand them out maybe, but then if they hand them out, he [Aaron] might not have been able to get them because someone else got them*").

Similarly, in the Cypriot site, one group identified relationships between the lawns mowed table and the money collected table. Although there were impressive discussions on all of the data tables, the students did not progress to identifying more complex mathematical ideas such as rates, because they did not take into account the hours worked table.

### **CONCLUDING POINTS**

There are a number of aspects of our joint study that have particular significance for the use of modeling in primary school mathematics. Our findings show how two classes of 10-year-olds in two different countries were able to work successfully on quite a complex mathematical modeling problem when presented as a meaningful, real-world situation. On the present problem, the children progressed through a number of modeling cycles, from focusing on subsets of information through to applying mathematical operations in dealing with the data sets, and finally, identifying some trends and relationships.

A most interesting aspect of this study lies in the similarities in solution approaches and model development displayed by the students in the two countries. Students with different educational and socioeconomic experiences and different cultural backgrounds developed very similar approaches to model creation for solving a real-world based problem.

Also of significance is students' engagement in self evaluation: groups in both sites were constantly questioning the validity of their solutions, and wondering about the representativeness of their models. This helped them progress from focusing on partial data to addressing all data in identifying trends and relationships in creating

better models. Although the students did not progress to more advanced notions such as rate (which was beyond the curriculum level in both countries), they nevertheless displayed surprising sophistication in their mathematical thinking. The students' developments took place in the absence of any formal instruction and without any direct input from the classroom teachers during the working of the problem. The next step in this international study is for the students in each country to share their models with their peers via a dedicated website.

## References

- Doerr, H.M. & English, L.D. (2003). A Modeling perspective on students' mathematical reasoning about data. *Journal of Research in Mathematics Education*, 34(2), 110-136.
- English, L. D. (2007). Mathematical modelling: Linking Mathematics, Science, and the Arts in the Elementary Curriculum. In A. Beckmann, C. Michelsen, & B. Sriraman (Eds.) *Proceedings of the Second International Symposium of Mathematics and its Connections to the Arts and Sciences*. University of Southern Denmark.
- English, L. D. (2006). Mathematical Modeling in the primary school. *Educational Studies in Mathematics*, 63(3), 303-323.
- English, L. D. & Lesh, R. A. (2003). Ends-in-view problems. In R. A. Lesh & H. Doerr (Eds.), *Beyond Constructivism: A Models and Modelling Perspective on Teaching, Learning, and Problem Solving in Mathematics Education* (pp. 297-316). Mahwah, NJ: Lawrence Erlbaum.
- Gravemeijer, K. (1999). How emergent models may foster the construction of formal mathematics. *Mathematical Thinking and Learning*, 1, 155-177.
- Greer, B. (1997). Modeling Reality in Mathematics Classroom: The Case of Word Problems. *Learning and Instruction*, 7, 293-307.
- Hamilton, E. (2007). What changes are needed in the kind of problem solving situations where mathematical thinking is needed beyond school? In R. Lesh, E. Hamilton, & J. Kaput (Eds.), *Foundations for the Future in Mathematics Education* (pp. 1-6). Mahwah, NJ: Lawrence Erlbaum.
- Hjalmarson, M. (2000). *Green Thumbs Garden to Open Soon*. Unpublished Modelling Problem. Purdue University.
- Lesh, R. A. & Doerr, H. M. (2003). *Beyond Constructivism: A Models and Modelling Perspective on Teaching, Learning, and Problem Solving in Mathematics Education*. Mahwah, NJ: Lawrence Erlbaum.
- Lesh, R. A. & Zawojewski, J. S. (2007). Problem solving and modeling. In F. Lester (Ed.), *Second Handbook of Research on Mathematics Teaching and Learning* (pp. 763-804). Greenwich, CT: Information Age Publishing.
- Mousoulides, N. (2007). *A Modeling Perspective in the Teaching and Learning of Mathematical Problem Solving*. Unpublished Doctoral Dissertation. University of Cyprus.
- Zawojewski, J. S., Lesh, R. A., & English, L. D. (2003). A models and modelling perspective on the role of small group learning. In R. A. Lesh & H. M. Doerr (Eds.),

*Beyond Constructivism: A Models and Modelling Perspective on Teaching, Learning, and Problem Solving in Mathematics Education* (pp. 337-358). Mahwah, NJ: Lawrence.

**APPENDIX**

**Aussie Lawn Mowing Problem: Green Thumbs Garden to Open Soon**

**Background Information:** At Green Thumb Gardens, James Sullivan will provide lawn-mowing service for his customers. Another local landscaping service has closed, so he has offered to hire 4 of their former employees in addition to taking on some of their former clients. He has received information from the other landscaping business about the employee schedules during December, January, and February of last year. The employees were responsible for mowing lawns and selling other yard products like fertilizer, weed killer, and bug spray. The other business recorded how many hours each employee worked each month, the number of lawns each employee mowed, and how much money they made selling other products. They also recorded the kilometres driven to clients in one of the green company trucks during each month.

**Problem:** James needs to decide which four employees he wants to hire from the old business for this summer. Using the information provided, help him decide which four people he should hire. Write him a letter explaining the method you used to make your decision so that he can use your method for hiring new employees each summer (The following **tables** were supplied [data for 5 of the employees have been omitted here]).

Hours Worked			
Employee	Dec.	Jan.	Feb.
Jonathan	80	80	80
Cynthia	75	65	70
Jack	66	64	63
Kayla	45	50	55
Tim	67	70	79

Kilometres Driven			
Employee	Dec.	Jan.	Feb.
Jonathan	198	200	201
Cynthia	199	201	198
Jack	197	199	198
Kayla	201	203	199
Tim	200	199	200

Money from Products Sold			
Employee	Dec.	Jan.	Feb.
Jonathan	\$150	\$175	\$170
Cynthia	\$75	\$80	\$80
Jack	\$125	\$150	\$150
Kayla	\$80	\$72	\$65
Tim	\$135	\$130	\$125

Total Number of Lawns Mowed									
Employee	December			January			February		
	Big	Medium	Small	Big	Medium	Small	Big	Medium	Small
Jonathan	15	12	30	16	14	34	16	15	35
Cynthia	18	10	35	19	12	35	14	16	36
Jack	14	16	22	15	16	22	13	16	22
Kayla	15	13	15	14	13	17	15	12	18
Tim	20	12	14	22	14	16	20	13	25

## AUTHOR INDEX

### VOLUME 3

- A**  
Aczel, James ..... 85  
Anthony, Glenda ..... 193
- B**  
Boileau, A. .... 249  
Bomer, Megan ..... 257
- C**  
Castro, Encarnación ..... 399  
Castro, Enrique ..... 399  
Chang, Peichin ..... 367  
Clow, Doug ..... 185  
Cortes, Viviana ..... 153
- D**  
Doritou, Maria ..... 97  
Drijvers, P. .... 249
- E**  
English, Lyn D. .... 423
- F**  
Fernandes, Hassan S. A. A. .... 137  
Fernández, Ceneida ..... 1  
Filloy, Eugenio ..... 9  
Font, Vicenç ..... 17  
Forgasz, Helen J. .... 25  
Frade, Cristina ..... 33  
Francisco, John ..... 41  
Fuglestad, Anne Berit ..... 49
- G**  
Gerofsky, Susan ..... 57  
Gerson, Hope ..... 65  
Gilmore, Camilla ..... 73  
Gómez, Pedro ..... 81  
González, María J. .... 81  
González-Martín, Alejandro S. .... 89  
Goodchild, Simon ..... 49  
Gray, Eddie ..... 97  
Grigoraş, Roxana ..... 105  
Guzmán, José ..... 249
- H**  
Hähkiöniemi, Markus ..... 113  
Halverscheid, Stefan ..... 105, 121  
Hannula, Markku S. .... 281  
Hattermann, Mathias ..... 129  
Healy, Lulu ..... 137  
Hedberg, John ..... 169  
Heinze, Aiso ..... 145  
Herbel-Eisenmann, Beth ..... 153  
Hernandez-Martinez, Paul ..... 161  
Highfield, Kate ..... 169  
Hitt, Fernando ..... 89  
Horne, Marj ..... 177  
Hosein, Anesa ..... 192  
Hunter, Jodie ..... 193  
Hunter, Roberta ..... 201  
Hwa, Tee-Yong ..... 297
- I**  
Ilany, Bat-Sheva ..... 209  
Inglis, Matthew ..... 73, 217
- J**  
Jacobs, Jennifer ..... 265  
Jones, Sonia ..... 225
- K**  
Kahn, Leslie H. .... 233  
Keene, Karen Allen ..... 241  
Kieran, Carolyn ..... 249  
Kim, Rae-Young ..... 321

Knapp, Andrea .....	257
Koellner, Karen .....	265
Koichu, Boris .....	273
Krzywacki-Vainio, Heidi .....	288
Kuntze, Sebastian .....	289

## L

Lau, Paul Ngee-Kiong .....	297
Leppäaho, Henry .....	305
Leu, Yuh-Chyn .....	337
Lew, Hee-Chan .....	313
Lipowsky, Frank .....	145
Llinares, Salvador .....	1
Lo, Jane-Jane .....	321, 337
Lozano, Maria-Dolores .....	329
Luo, Fenqjen .....	337
Lupiáñez, José L. ....	81

## M

Machado, Milene Carneiro .....	33
Mamede, Ema .....	345
Mamolo, Ami .....	353
Margolin, Bruria .....	209
McCrary, Raven .....	321
McLeman, Laura Kondek .....	233
Menéndez-Gómez, J. María .....	233
Mesa, Vilma .....	367
Metaxas, Nikolaos .....	375
Meyer, Michael .....	383
Misailidou, Christina .....	391
Molina, Marta .....	399
Moore, Cynthia .....	257
Moore-Russo, Deborah .....	407
Mosqueda, Eduardo .....	415
Morasse, Christian .....	89
Mousoulides, Nicholas G. ....	423

Mulligan, Joanne .....	169
Musanti, Sandra I. ....	233

## N

Nunes, Terezinha .....	345
------------------------	-----

## P

Planas, Núria .....	17
---------------------	----

## R

Richardson, John T.E. ....	185
Rico, Luis .....	81
Rojano, Teresa .....	9

## S

Simpson, Adrian .....	217
So, Kum-Nam .....	313
Solares, Armando .....	9

## T

Tanguay, D. ....	249
Tanner, Howard .....	225
Télez, Kip .....	415
Trujillo, Barbara .....	233

## V

Valls, Julia .....	1
--------------------	---

## W

Wagner, David .....	153
Walter, Janet G. ....	65
Watson, Kelly .....	177

## Z

Zazkis, Rina .....	35
--------------------	----

